

Technical Specifications

55566

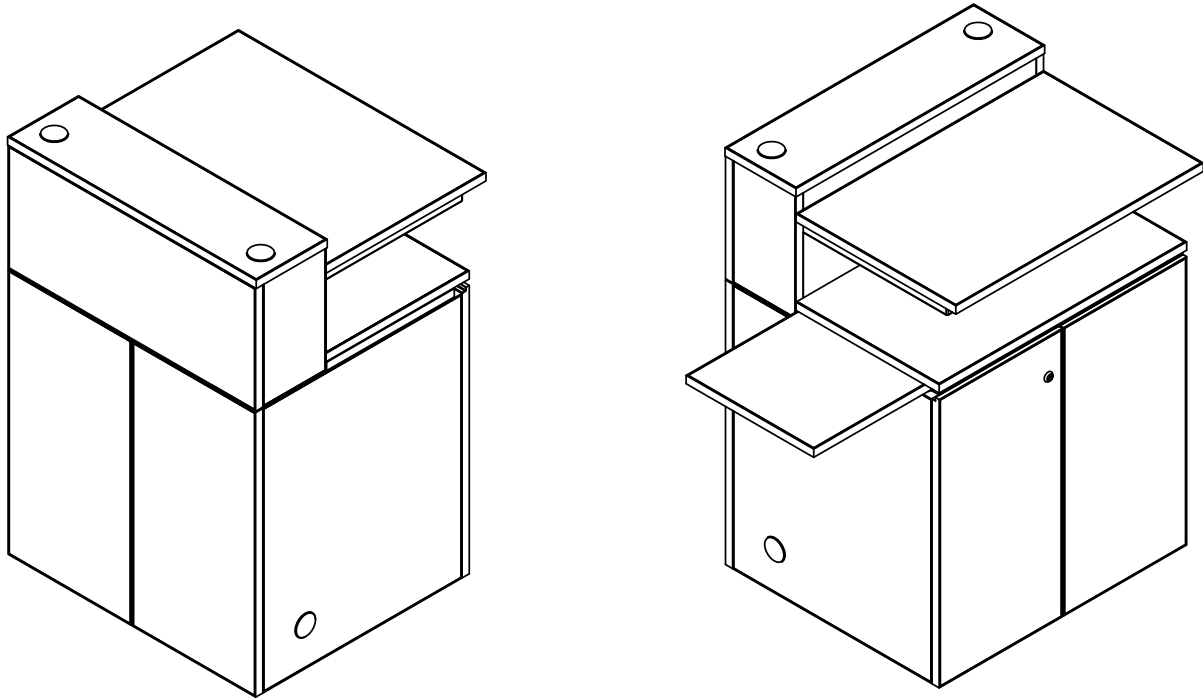

Clean lines and customization set the Edge Lectern apart from the rest. Customize the vertical and horizontal laminate panels separately with any of our Expressions colors to design a modern lectern, unique to you and your environment. Two worksurfaces and a slide-out shelf make this the perfect lectern to organize your space and give your presentations the edge.



Features and Benefits

- Designed with primary, secondary, and a slide-out shelf to maximize workspace
- Top worksurface and grommets can be used to install monitor arms and route cords
- Additional worksurface space below the main worksurface provides extra room for peripherals
- Slide-out shelf shifts left or right and stops can be adjusted as needed
- Available with (1) internal adjustable shelf, (1) 12RU Rack Cube, or no internal storage accessory
- Locking instructor-side and audience-side doors with adjustable European style hinges provide interior access
- Audience-side, top panel lifts to access cables and lock for audience-side doors
- 2 locking and 2 non-locking casters provide mobility
- Metal worksurface support and logo panel come in our Expressions colors
- Choose up to two laminates (for vertical and horizontal panels) for a custom look
- Add branding with the optional logo panel
- Optional adjustable shelf or 12RU Rack Cube are available separately
- Scratch and impact-resistant high-pressure laminate worksurfaces
- Each unit is factory-assembled with casters, packaged and shipped on its own skid
- Warranted to be free of all defects in materials and workmanship for 10 years
- Designed and assembled in Chippewa Falls, WI, USA

Color Options

Available in Spectrum Expressions colors.
See [spectrumfurniture.com](https://www.spectrumfurniture.com) for complete color information.

Construction

- The worksurfaces are constructed from 3/4" thick NAF (no added formaldehyde) composite board with .030" [.762mm] high-pressure laminate on one face, and balancing black laminate on the opposing face
- Worksurface edges are covered with vinyl edgeband
- All metal components are finished with a scratch-resistant powder coat epoxy
- Each unit is factory-assembled with casters, packaged and shipped on its own skid

Specifications

Twin-wheel casters (2 locking, 2 non-locking)	<ul style="list-style-type: none"> • Diameter: 3" [7.62 cm] • Weight capacity: 165 lb [75 kg] each
Internal adjustable shelf (optional)	<ul style="list-style-type: none"> • 26.125"W [66.36 cm] x 16"D [40.64 cm] • 14" [35.56 cm] of vertical shelf adjustment • Multiple optional shelves can be added
Rack Cube (optional)	12RU front and rear
Certifications / Compliance	Meets or exceeds applicable ANSI-BIFMA test standards
Unit weight (nominal)	170 lb [77.2 kg]
Shipping weight (nominal)	212 lb [96 kg]

Specifications subject to change without notice

Twin-wheel casters

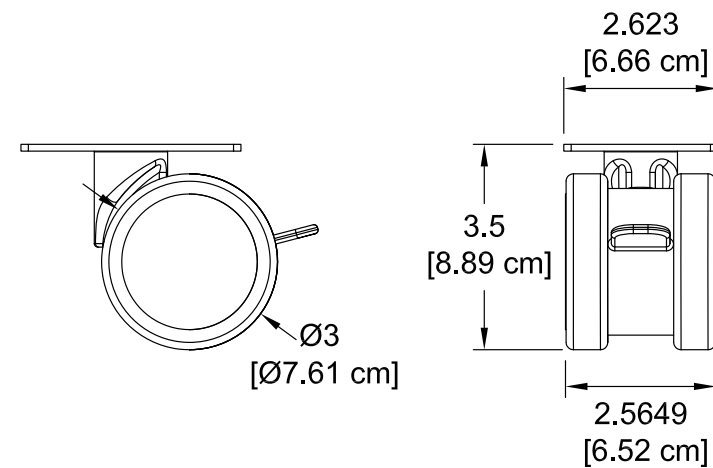
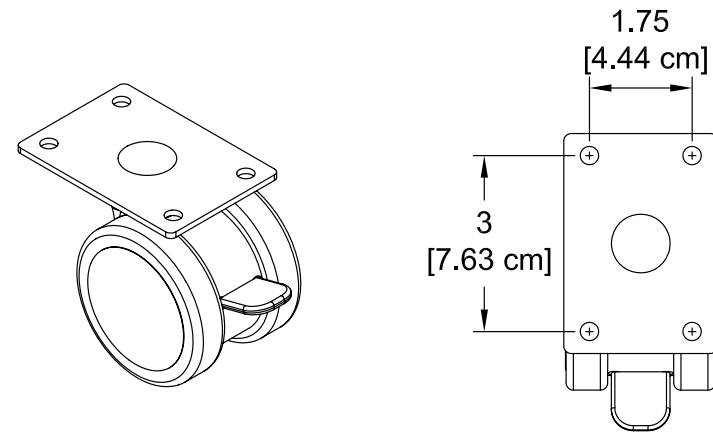

Worksurface edge

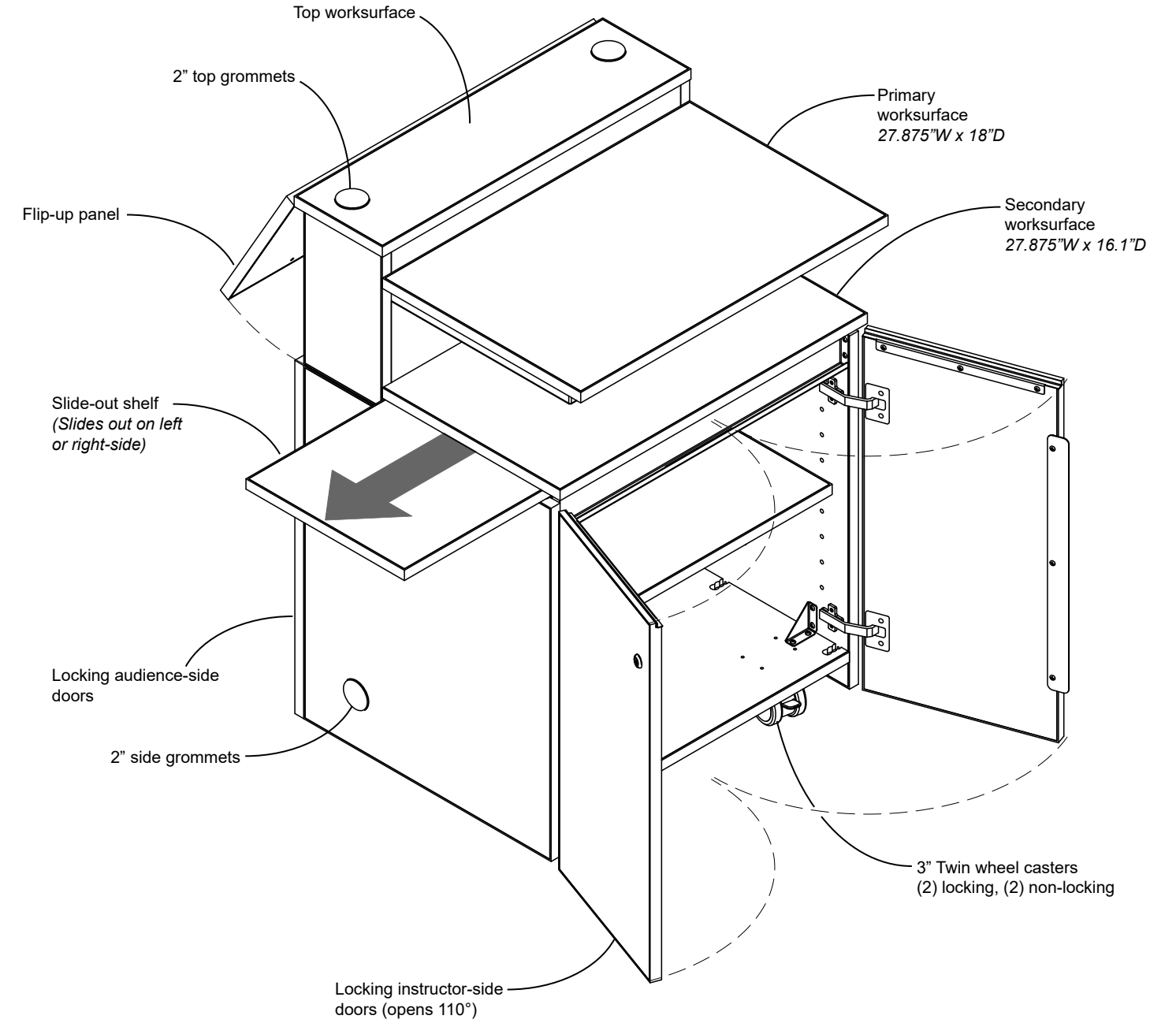
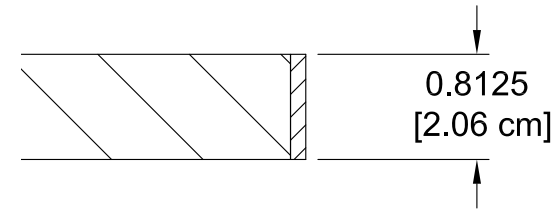

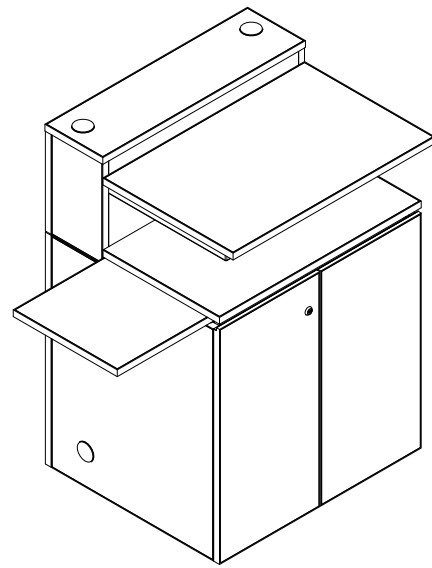

Edge Lectern

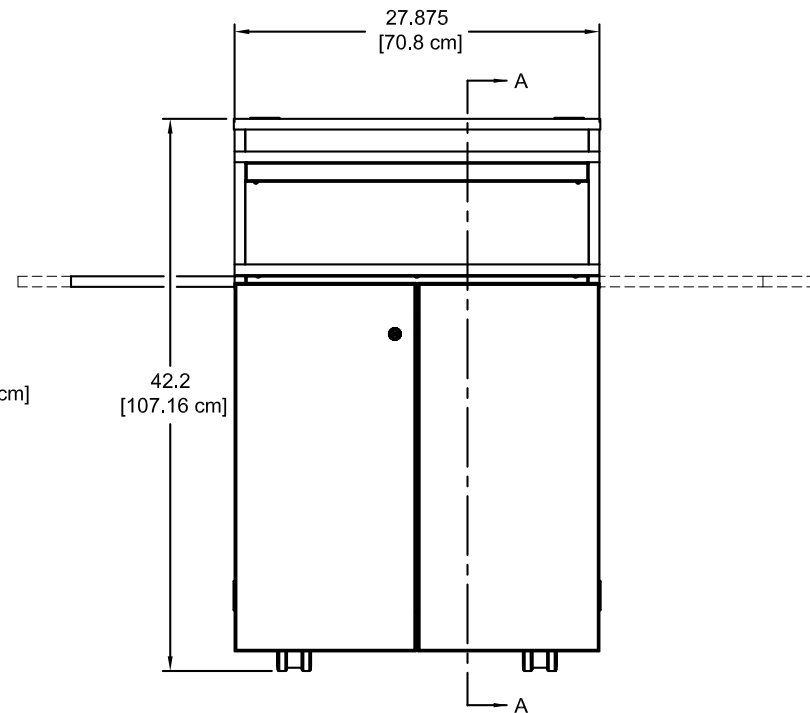
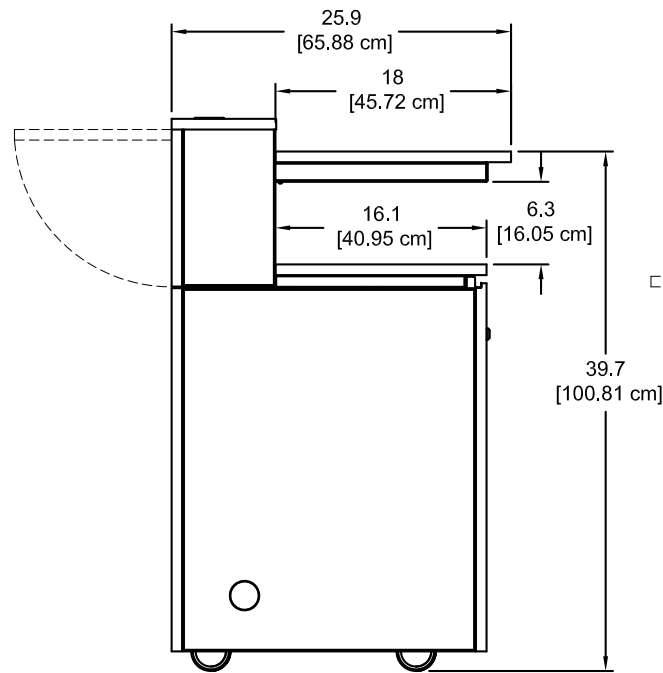
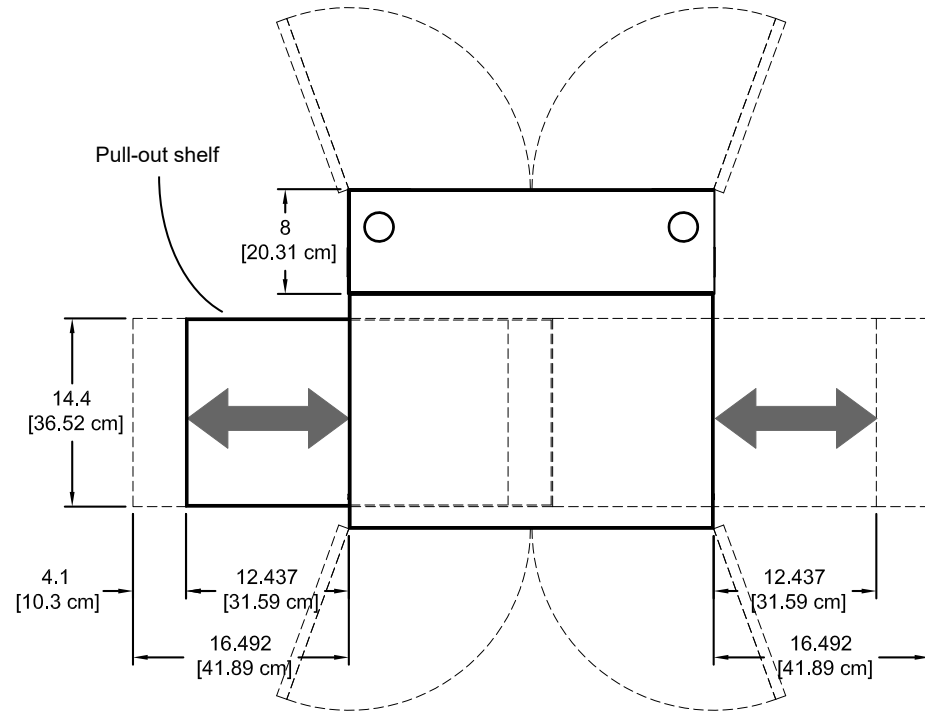

Note: The single pull-out shelf will extend up to 12.437" (factory setting) from the left or right-side of the lectern. Repositioning an internal bumper will add an additional 4" for 16.492" of total extension.

Section View A-A
(With optional adjustable shelf)

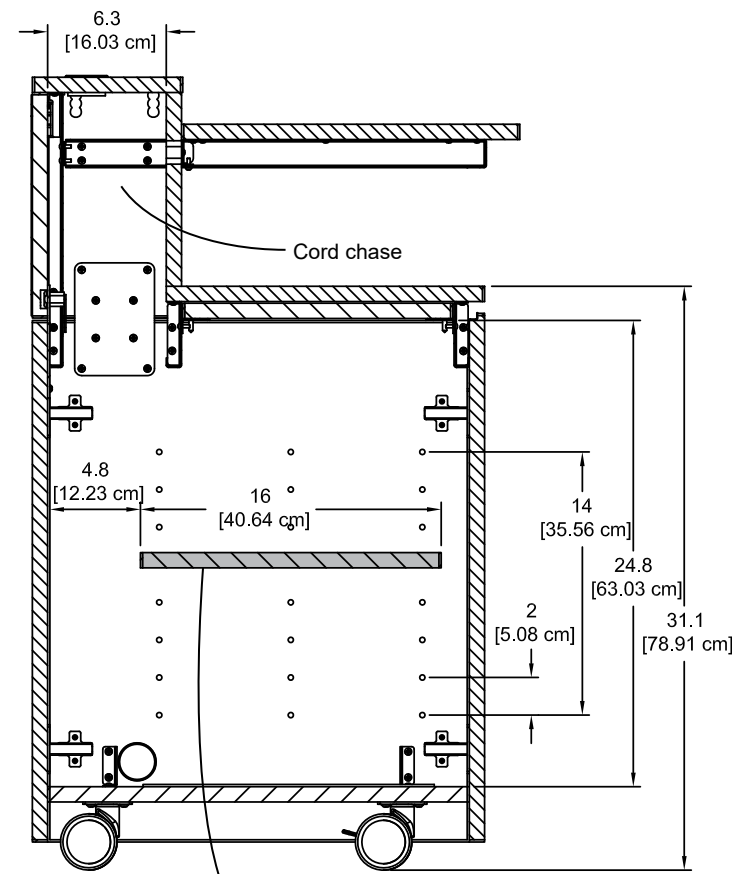

Optional adjustable shelf:
26.125"W x 16"D

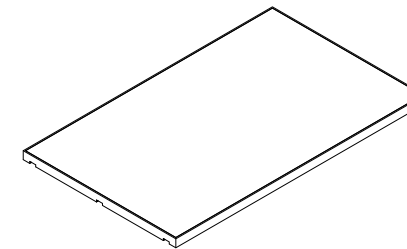

Section View A-A
(With optional 12RU Rack Cube)

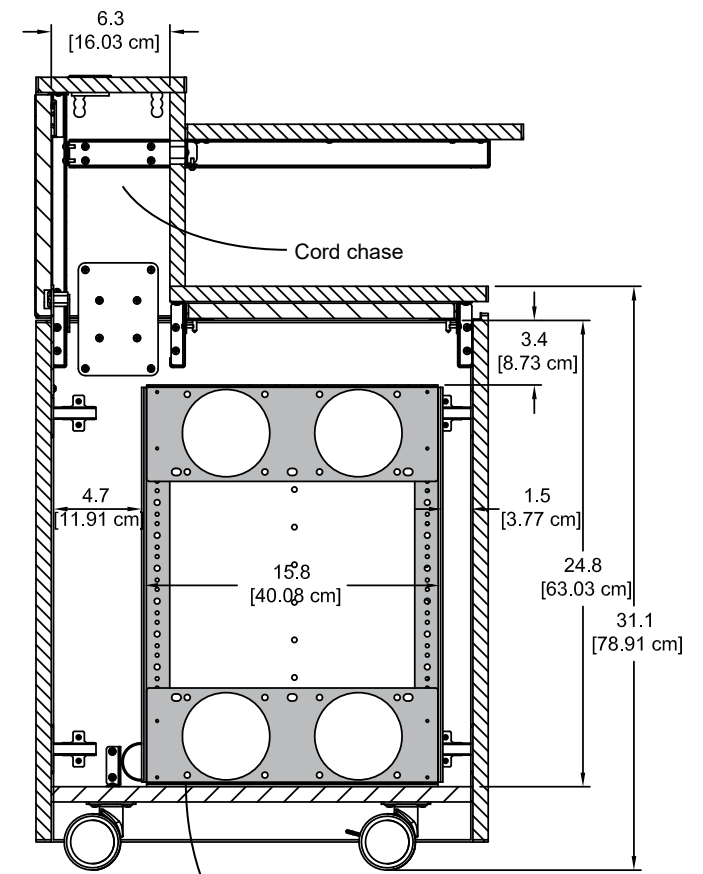

Optional 12RU Rack Cube

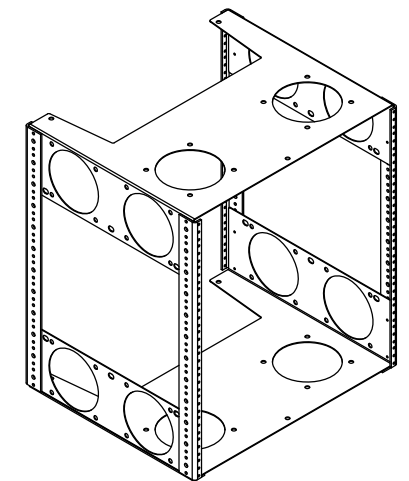

Note: The lectern will accommodate optional adjustable shelves or the optional 12RU Rack Cube. They cannot be installed at the same time.

Max cutout area in top worksurface

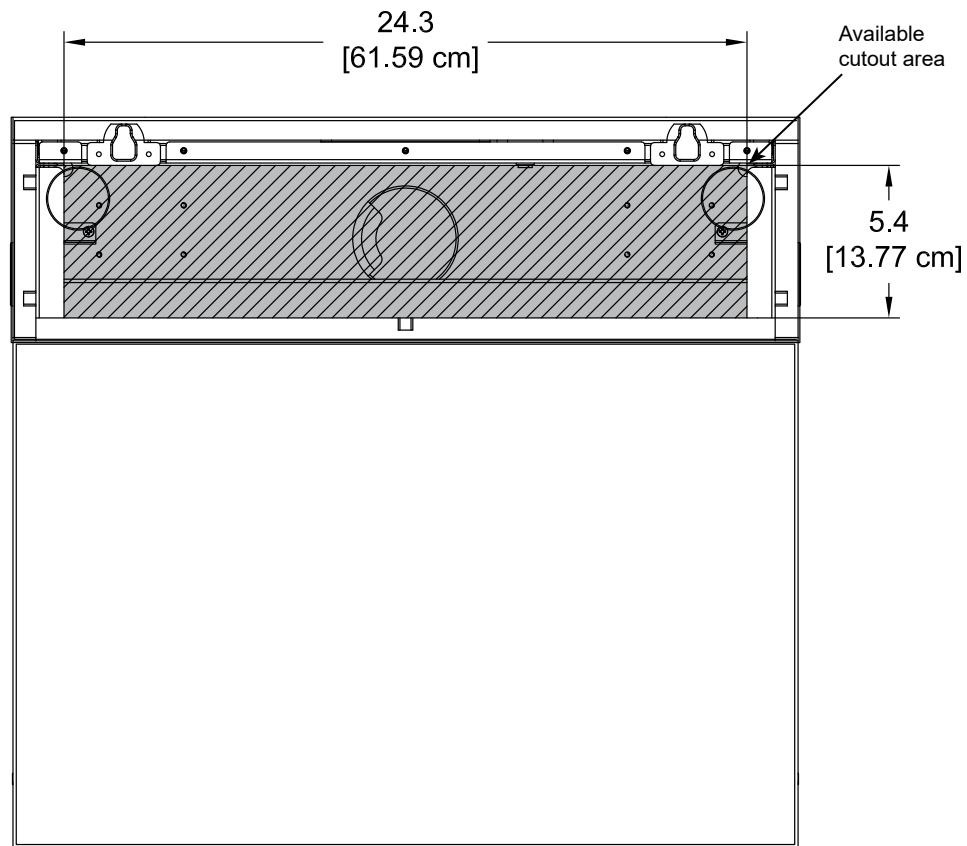

Please contact Spectrum with preferred accessories and cutouts for assistance with worksurface cutout placement.

Cutouts can be made in the worksurface by the customer after the lectern has been purchased, but only are recommended within the maximum cutout area shown.

Accessories

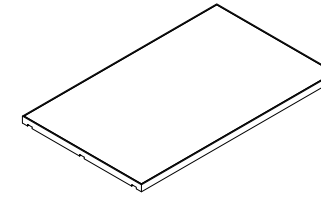

Adjustable shelf - 55567

- Black laminate
- Dimensions: 26.13"W [66.4 cm] x 16"D [40.6 cm] x .75"H [1.9 cm]
- Unit weight: 5 lb [12.7 kg]
- Shipping weight: 6 lb [15.2 kg]

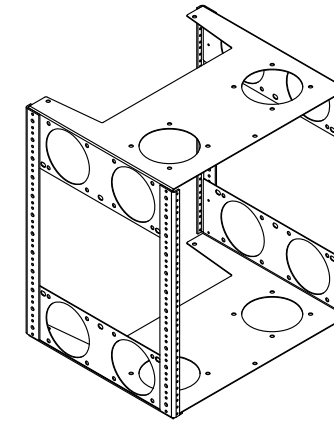

12RU Rack Cube - 55228

- Provides the ability to integrate equipment remotely before installation into the unit
- Polyethylene slides on bottom for easy removal
- Can be secured to base panel
- Cooling fan compatible
- Color: black
- Customer-installed

Rack rail:	12RU front and rear
Dimensions:	19.105"W [48.5 cm] x 16.03"D [40.7 cm] x 21.375"H [54.3 cm]
Mounts for cooling fans:	Compatible with most 4.7" fans with 4.13" mounting hole spacing (12 mounting locations available)
Unit weight:	21 lb [9.5 kg]
Shipping weight:	22 lb [10 kg]

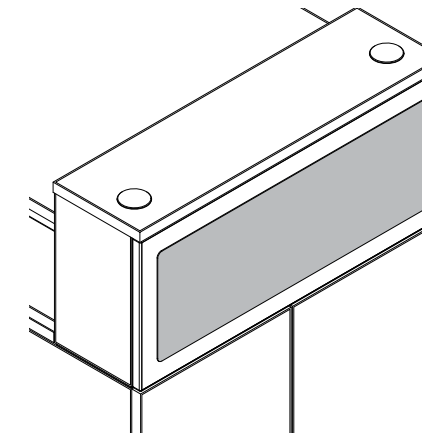

Customized Metal Logo Panel - 55568

- Attaches to audience-side of lectern
- Available with black, white, or matching laminate backer
- To get panel customized-contact Spectrum for details
- New logos require a first time logo charge

Dimensions:	24.9"W [63.2 cm] x 8.765"H [22.3 cm]
Available logo area:	23.86"W [60.6 cm] x 6.485"H [16.5 cm]
Unit weight:	4 lb [1.8 kg]
Shipping weight:	5 lb [2.3 kg]

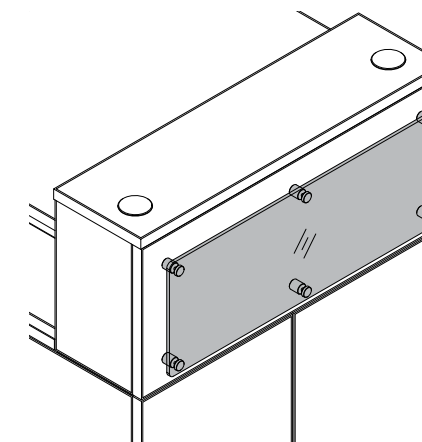

Customized Acrylic Logo Panel - 55568

- Attaches with standoffs to audience-side of lectern
- Clear acrylic mounted on standoffs
- New logos require a first time logo charge
- Customer-installed
- To get panel customized-contact Spectrum for details

Dimensions:	18.5"W [47 cm] x 9"H [22.86 cm]
Unit weight:	2.53 lb [1.15 kg]
Shipping weight:	3.53 lb [1.6 kg]

Rack-mount Accessories

(Requires 12RU Rack Cube - 55228)

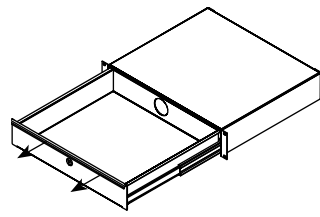

Locking Drawer - 2RU - 97527

- 16ga steel
- Drawer: 15.97"W [40.56 cm] x 14.56"D [36.98 cm] x 3"H [7.63 cm]
- Weight capacity: 50 lb [22.7 kg]
- Shipping weight: 15.85 lb [7.2 kg]

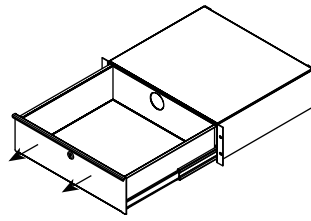

Locking Drawer - 3RU - 97526

- 16ga steel
- Drawer: 15.97"W [40.56 cm] x 14.56"D [36.98 cm] x 5.25"H [13.33 cm]
- Weight capacity: 50 lb [22.7 kg]
- Shipping weight: 18.5 lb [8.4 kg]

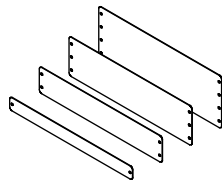

Rack-Mount Blanks

1RU - 97510 3RU - 97512
2RU - 97511 4RU - 97513

- Fills rack spaces where components are not needed
- 16 ga steel
- Shipping weight: <1 lb [.45 kg]

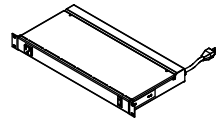

9-Outlet Power Strip - 1RU - 99021

- 8 outlets rear (breaker-protected)
- 1 convenience outlet front
- 115VAC, 60 Hz, 15 amps max
- 9' power cord
- Front LED power switch
- Enhanced surge protection
- ETL-listed, UL-listed
- 19"W [48.27 cm] x 9.25"D [23.5 cm] x 1.74"H [4.41 cm]
- Shipping weight: 8.7 lb [3.9 kg]

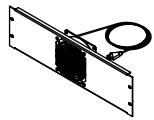

Single Fan - 3RU - 97507

- 50 cfm
- 120V~50/60 Hz, 15/13W
- RoHS
- 19"W [48.27 cm] x 1.56"D [3.97 cm] x 5.25"H [13.33 cm]
- Shipping weight: 3.78 lb [1.7 kg]

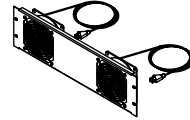

Double Fan - 3RU - 97506

- 100 cfm
- 120V~50/60 Hz, 15/13W
- RoHS
- 19"W [48.27 cm] x 1.56"D [3.97 cm] x 5.25"H [13.33 cm]
- Shipping weight: 5.47 lb [2.5 kg]

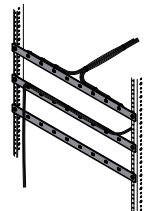

Wire Lace Kit - 95517

- Provides wire management
- Mounts to standard rack rails
- Includes (3) lace straps and mounting screws
- Includes (12) 5.5" zip ties
- Shipping weight: 1.25 lb [.57 kg]



7-Outlet Power Strip - 99024

- Electrical Rating: AC 125V, 15 Amps
- 1000 Joules surge capacity
- 12' cord length
- LED switch
- UL Listed
- Shipping weight: 1.9 lb [.86 kg]



See [spectrumfurniture.com](https://www.spectrumfurniture.com) for complete details on Spectrum's full line of monitor arms.

See [spectrumfurniture.com](https://www.spectrumfurniture.com) for the latest accessories and detailed warranty information.

Warranty

We will make it right for you!

Thanks for choosing Spectrum! Spectrum is committed to provide complete customer satisfaction. Each of our products is manufactured from the best materials available and each product is stringently monitored throughout the production process through our P.A.C.E. program (Product Assurance to meet Customer Expectations).

We expressly warrant that Spectrum products will be of good quality and workmanship and free from defect for the period set out in the warranty from the date of delivery.

For a listing of all product specific warranty terms please visit our website at:

<https://www.spectrumfurniture.com/en/resources/purchasing-terms-warranty>

1-800-235-1262

Toll-free HELPLINE

spectrum@spectrumfurniture.com