

Technical Specifications

55558

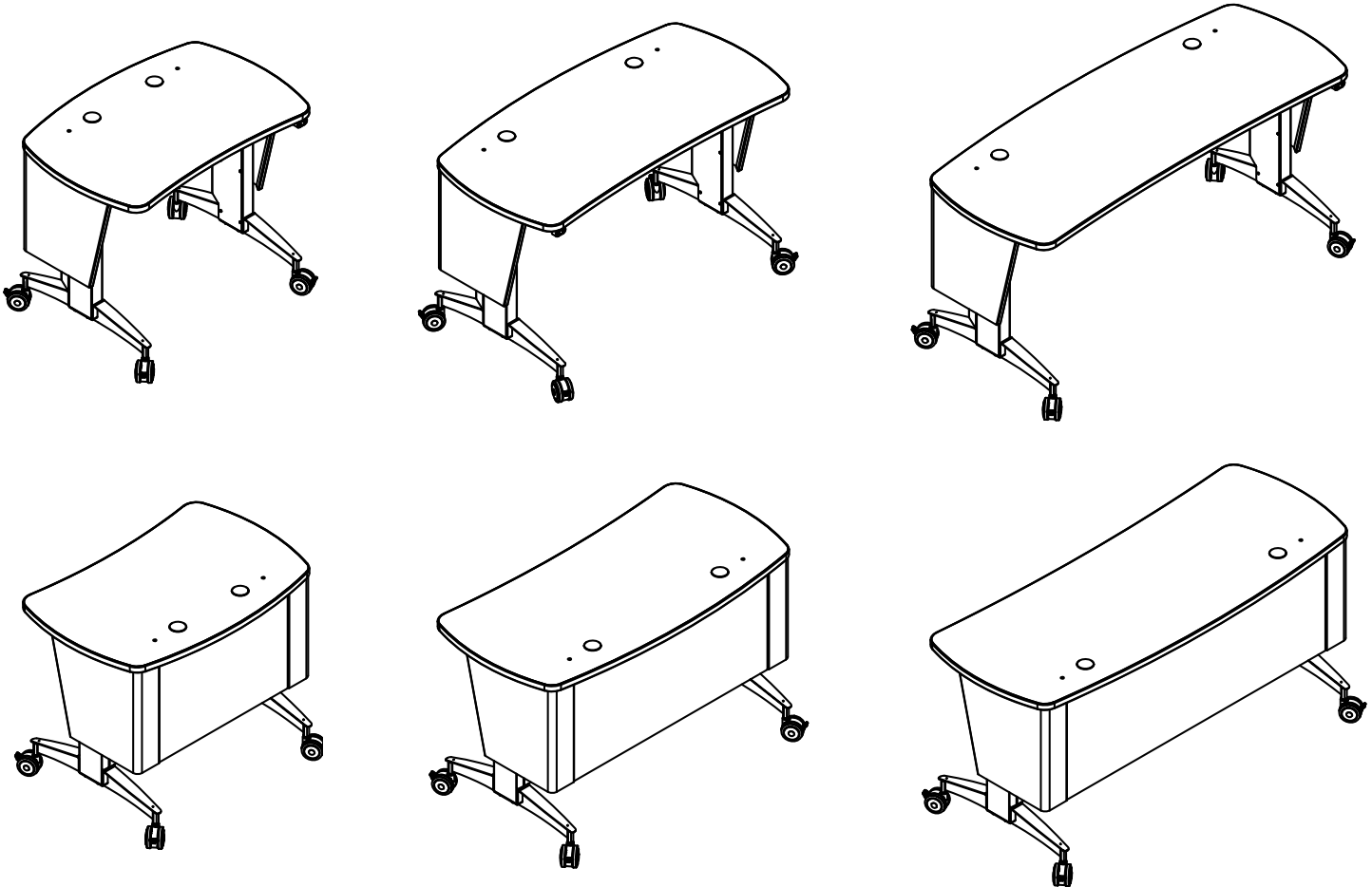

36"W Pivot Premier Workstation™

48"W Pivot Premier Workstation™

60"W Pivot Premier Workstation™



The sit-to-stand Pivot Premier Workstation™ was designed for today's integrated, active, higher-ed learning environments. Available in three widths, this mobile workstation has a large, height-adjustable worksurface and a wide variety of options to adapt to any situation.

Features and Benefits

- Electric telescoping legs adjust worksurface height from 28.5"-42"H
- Available in 36"W, 48"W, or 60"W versions
- Scratch and impact-resistant high-pressure laminate worksurface
- Durable powder coated steel chassis provides a long-lasting finish
- Worksurface vinyl edging protects walls and furniture
- Worksurface grommets provide cable access
- Twin-wheel casters provide easy mobility (all 4 locking)
- Standard laminate colors available to match existing furniture
- 48"W and 60"W versions remains ADA-compliant when used with (1) CPU sling
- Cord management chase on audience-side of each leg provides a safe route for cables to the floor and keeps cords away from instructor
- Optional Mobile Equipment Rack
- Optional Undermount Rack Cabinet
- Optional Undermount AV Channel with mounting slots provide multiple mounting options for AV over IP decoders or other light AV electronics
- Optional pull-out keyboard tray
- Optional CPU sling provides mounting for CPU tower
- Optional worksurface power module with AC power plug (requires worksurface cutout)
- Optional logo panel and laminate insert
- Ships KD (knocked down) and requires assembly
- Meets or exceeds applicable ANSI-BIFMA test standards
- Warranted to be free of all defects in materials and workmanship for 10 years
- Designed and assembled in Chippewa Falls, WI, USA

Color Options

Available in Spectrum Expressions colors. See spectrumfurniture.com for complete color information.



Ordering Instructions

Spectrum has designed this product to receive the useful options shown here. To ensure your options are ordered correctly please call 1-800-235-1262.

Construction

- The worksurface, base panel, and surround is constructed from 1" thick composite board with .030" high-pressure laminate on one face, and a balancing phenolic backer on the opposing face
- Leg components consist of 7-gauge steel
- Worksurface edges are covered with 3mm vinyl
- All metal components are finished with a scratch-resistant powder coat epoxy
- Each Pivot Premier Workstation is shipped KD (Knocked-Down) and requires assembly.

Specifications

Worksurface height adjustability (floor to top of worksurface)	42"H [106.7 cm] (fully-raised) 28.5"H [72.4 cm] (fully-lowered)
Max worksurface capacity	360 lb [163.4 kg]
Twin-wheel casters	<ul style="list-style-type: none"> • Diameter: 3" • Locking: all 4 casters • Weight capacity: 165 lb [75 kg] each
ADA-compliance*	<p style="text-align: right;">Knee clearance:</p> <ul style="list-style-type: none"> • 36"W Workstation: 25.5"W [64.8 cm] x 19.4"D [49.3 cm] x 27.5"H [69.9 cm] (<i>36"W Not ADA-Compliant</i>) • 48"W Workstation: 37.5"W [95.3 cm] x 19.4"D [49.3 cm] x 27.5"H [69.9 cm] • 60"W Workstation: 49.5"W [125.7 cm] x 19.4"D [49.3 cm] x 27.5"H [69.9 cm] <p>(1 person per workstation)</p>
  	<p>*Minimum ADA guidelines for knee clearances are 30"W [76.2 cm] x 19"D [48.3 cm] x 27"H [68.6 cm]</p> <p>Note: Worksurface with keyboard trays must be raised higher to provide ADA clearance. The workstation is ADA compliant with up to (1) CPU sling or (1) Undermount Rack Cabinet.</p>
Electrical	<ul style="list-style-type: none"> • Range of motion: 13.5" [34.3 cm] • ~10 seconds from fully-lowered to fully-raised • Inverter: 120V @ 60Hz, max output 300 watts • Motors: 18V / 10 amps • Typical electrical load during operation: <u>4.3 amps @ 120 VAC</u> • Anti-collision protection <ul style="list-style-type: none"> • 8' [243 cm] nominal 3-wire power cord • Max load: 1200N (270 lb) [122.6 kg] per actuator total lift capacity: 540 lb [245 kg] • Actuators feature non-hydraulic, permanently lubricated screw jacks • Actuators rated for 20,000 cycles • Approved according to EN 60335-1 and UL 962
Certifications / Compliance	<ul style="list-style-type: none"> • SCS Indoor Advantage Certified • Meets or exceeds applicable ANSI-BIFMA test standards
Unit weight (nominal)	99.5 lb [45.2 kg] - 36"W 111.5 lb [50.6 kg] - 48"W 123.5 lb [56 kg] - 60"W
Shipping weight (nominal)	131 lb [59.5 kg] - 36"W 143 lb [65 kg] - 48"W 155 lb [70.4 kg] - 60"W

Specifications subject to change without notice

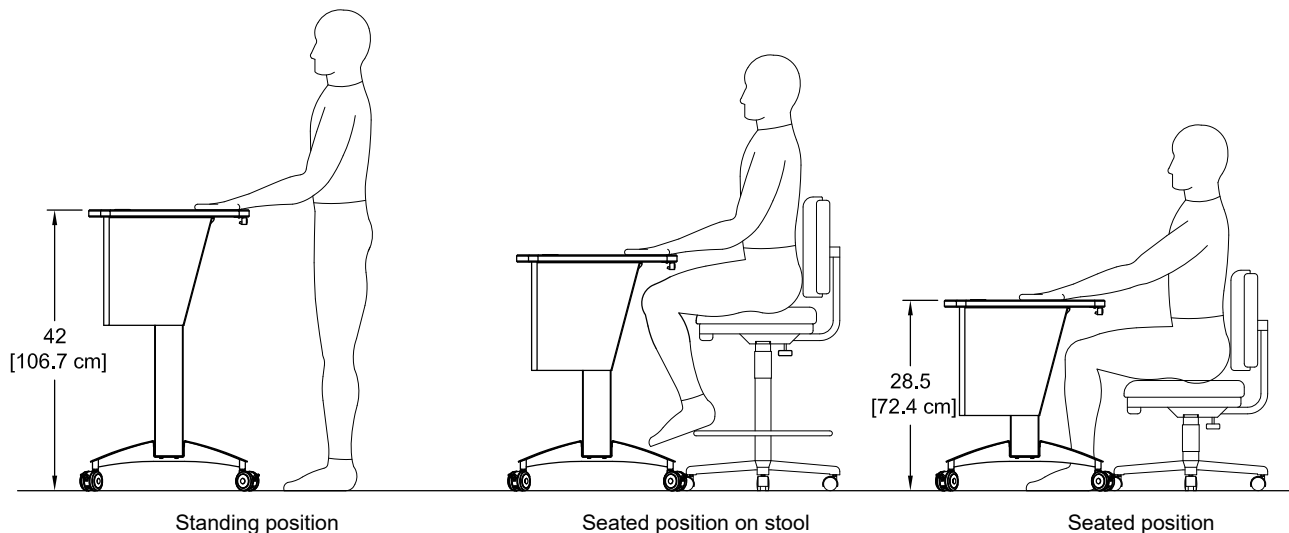

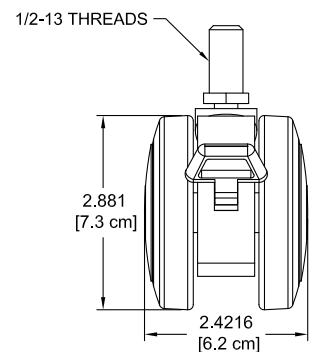
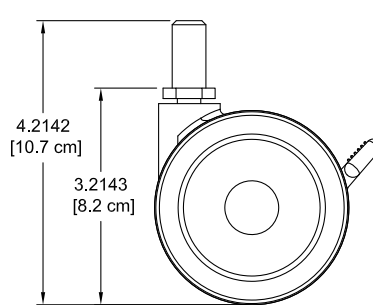
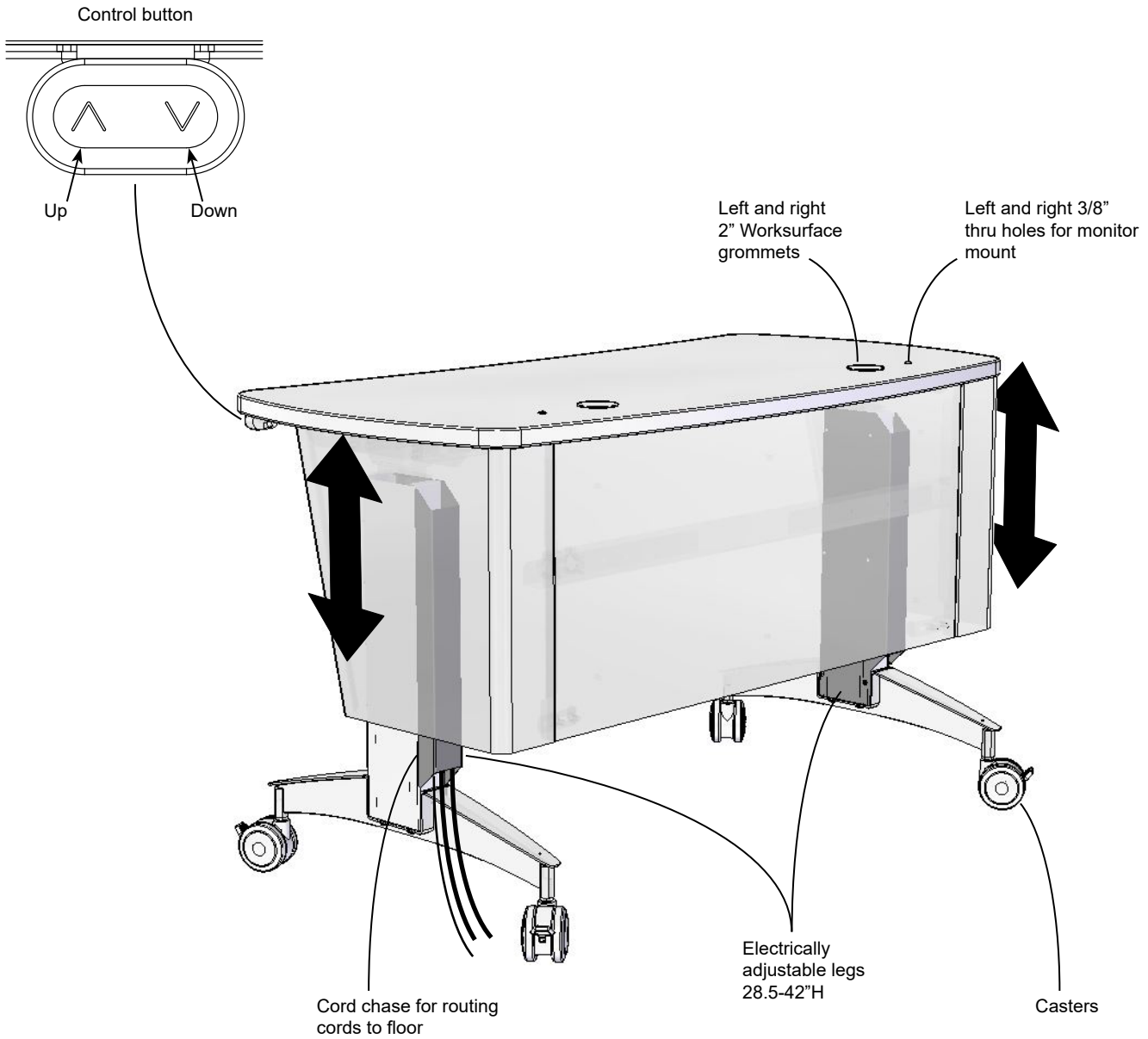

Worksurface size

ORDER CODE 1 = 36"W Worksurface

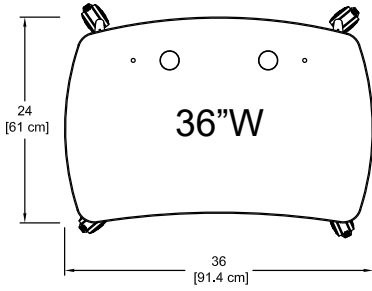

ORDER CODE 3 = 48"W Worksurface

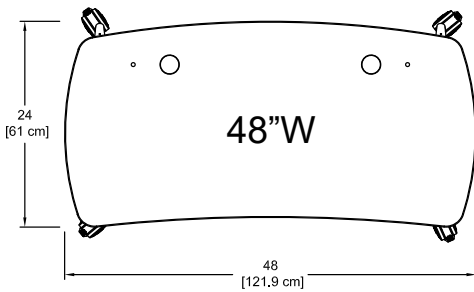

ORDER CODE 5 = 60"W Worksurface

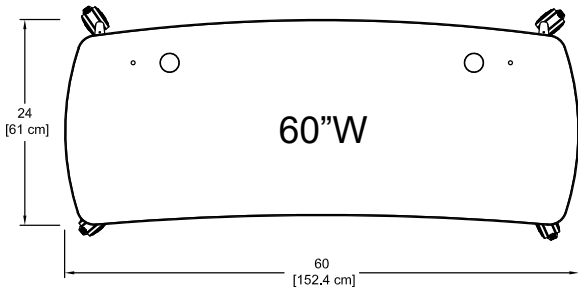

Power Module option

ORDER CODE 0 = None

ORDER CODE A = Power Module - Black

ORDER CODE B = Power Module - Silver

ORDER CODE C = Power Module - White

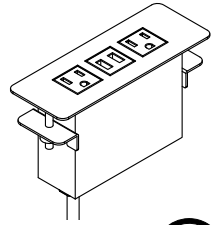

- Factory-installed
- (2) AC receptacles (tamper-resistant)
- (1) USB charge port
- (1) USB-C charge port
- Aluminum housing and flange
- 10' 14AWG *3C power cord
- When specified, the Power Module is centered on the audience-side edge of the worksurface
- Worksurface cutout size: 5.65"W x 1.65"D
- Available in black, silver, or white
- ETL-certified

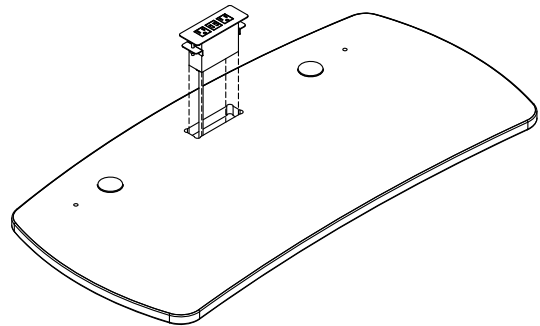

Cutout options

ORDER CODE 00 = None

ORDER CODE 01 = Custom cutout(s)



Please contact Spectrum with preferred accessories and cutouts for assistance with worksurface cutout placement.

Logo Panel option

Customized Metal Logo Panel

ORDER CODE 0 = None
ORDER CODE 1 = Custom logo w/ matching laminate backer
ORDER CODE 3 = Custom logo w/ black laminate backer
ORDER CODE 4 = Custom logo w/ white laminate backer
ORDER CODE 5 = Custom printed backer

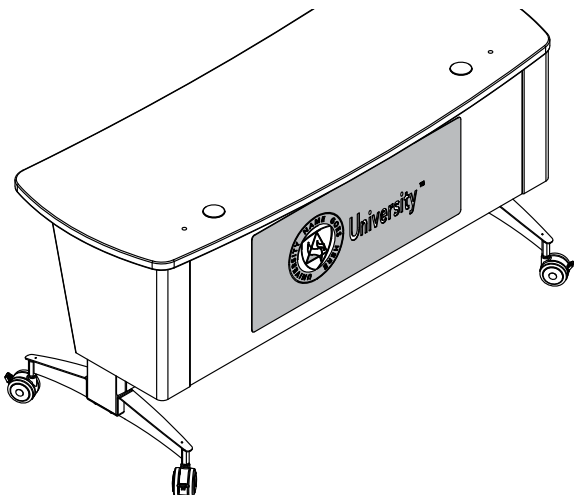
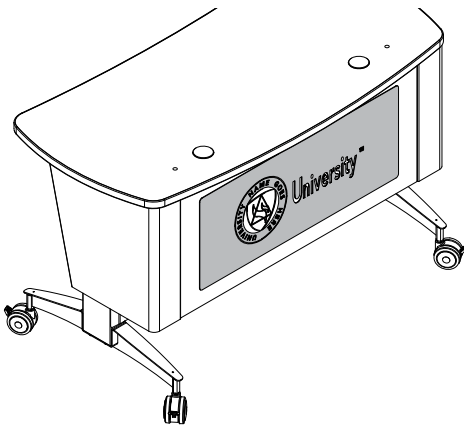
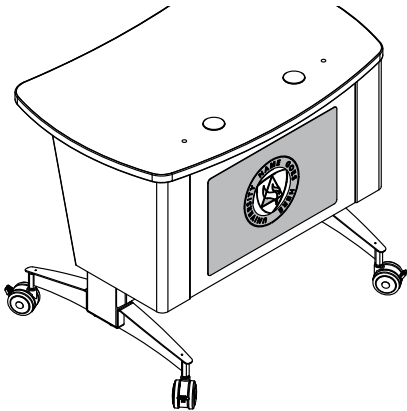

Customized Acrylic Logo Panel

ORDER CODE 6 = Acrylic logo panel
--

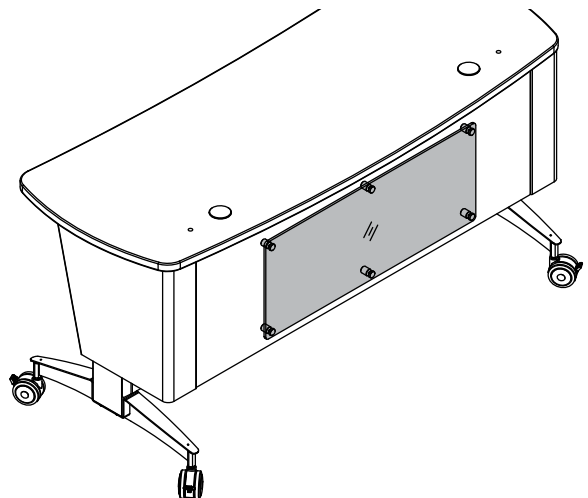
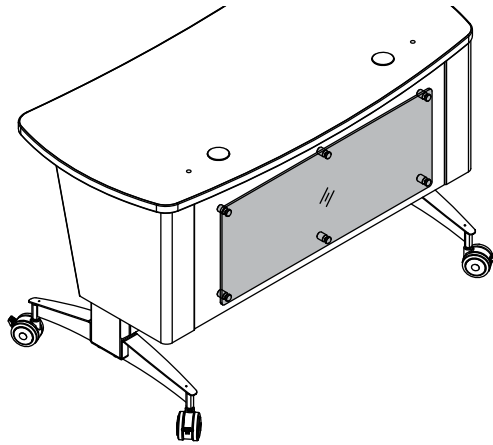
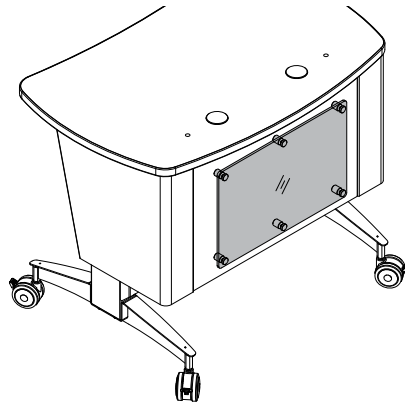

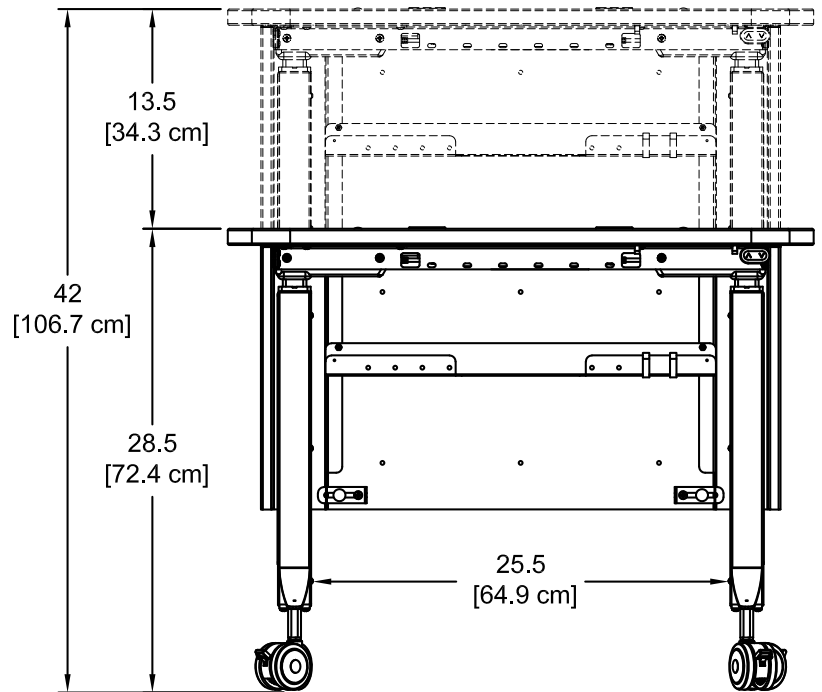
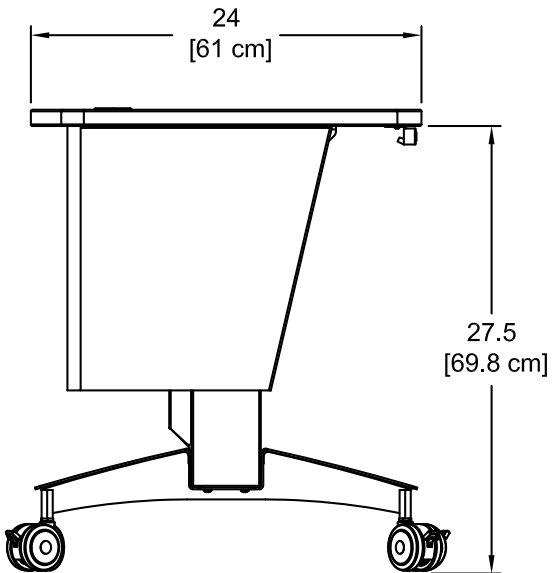
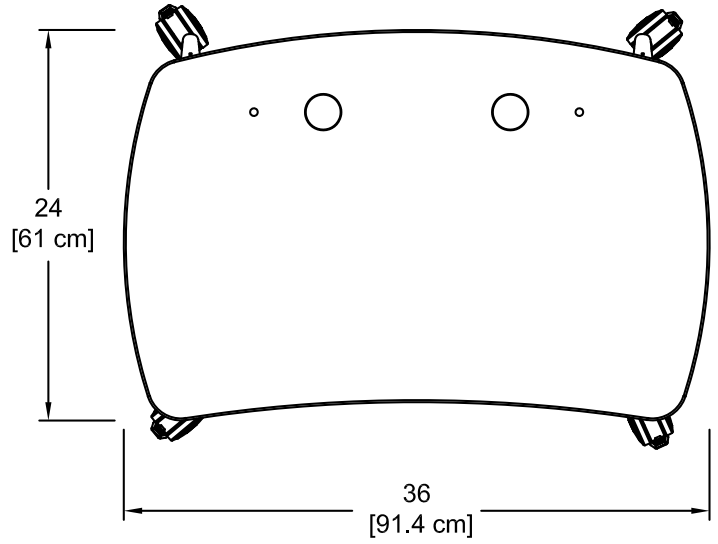
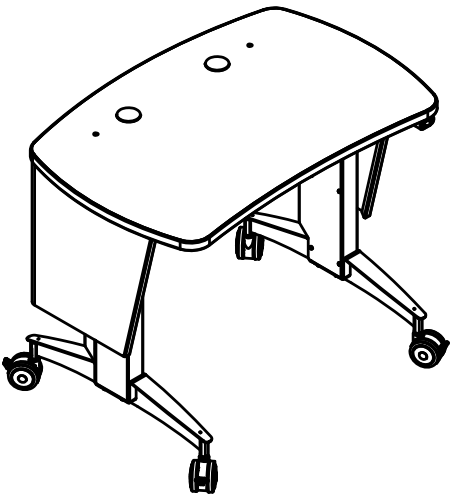

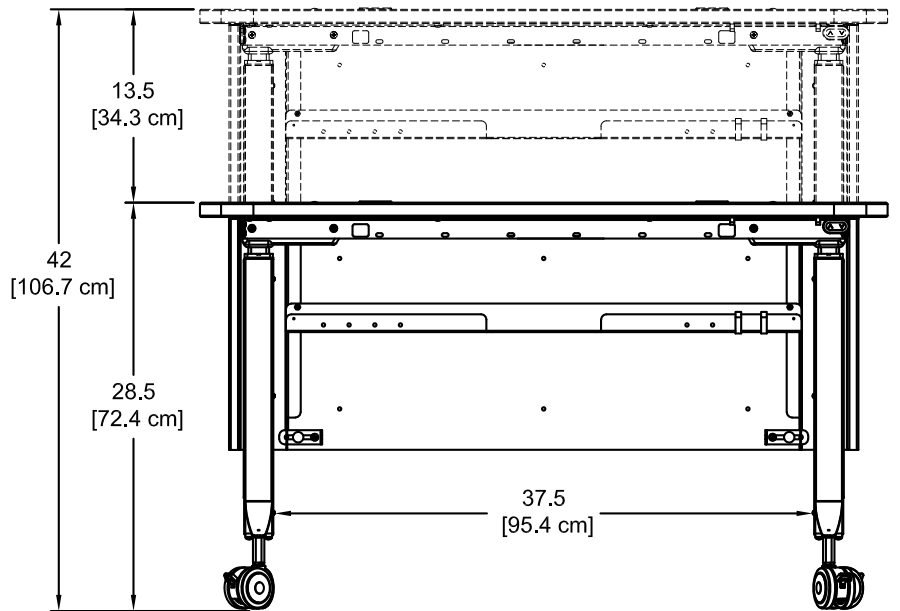
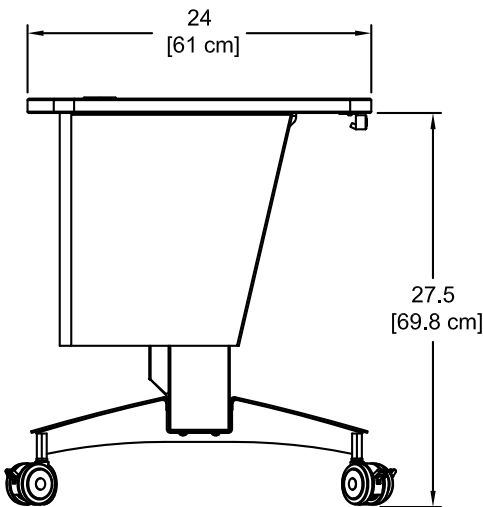
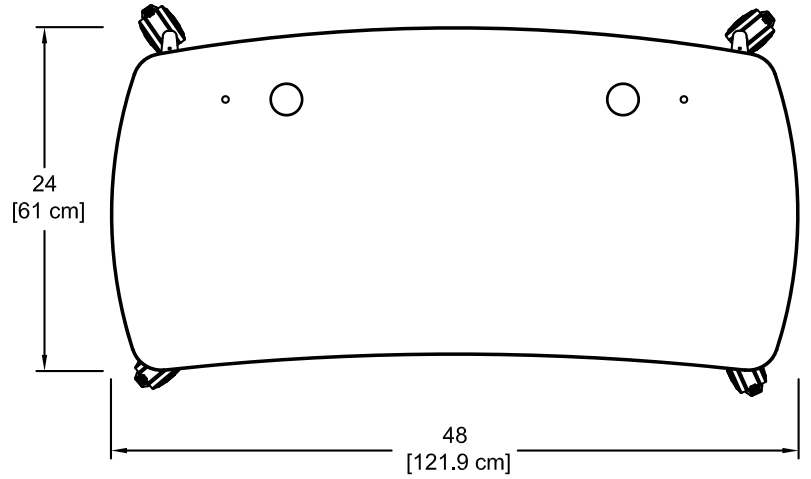
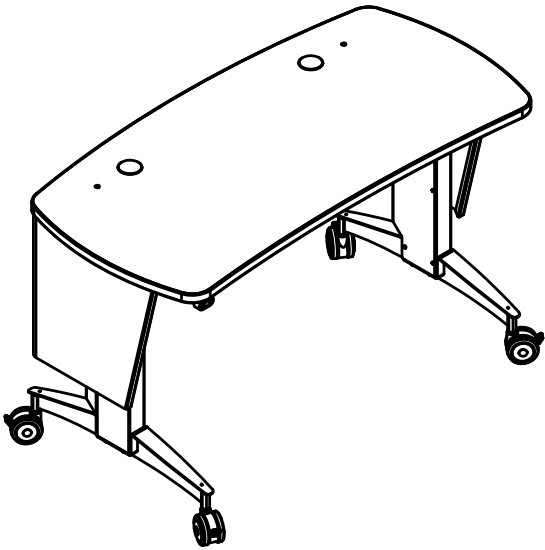

60"W Pivot Premier Workstation

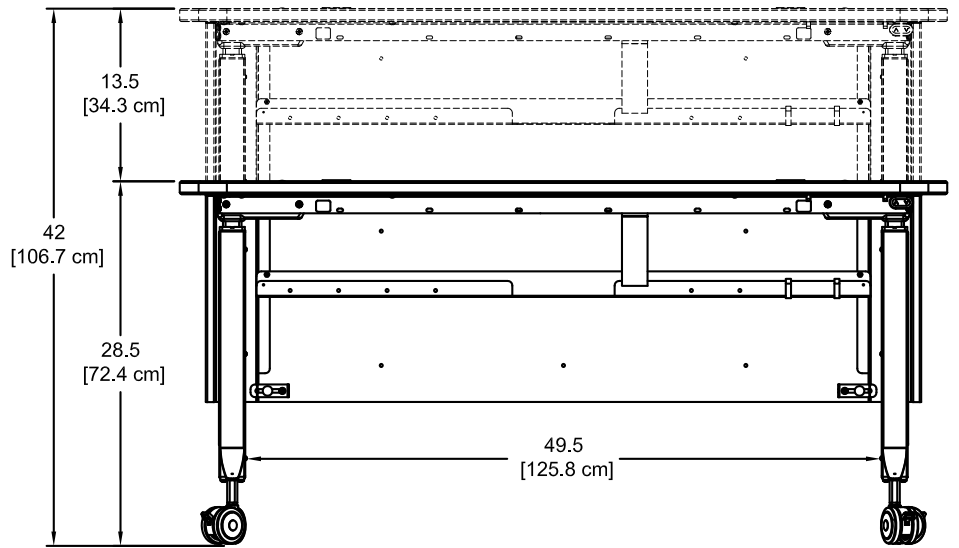
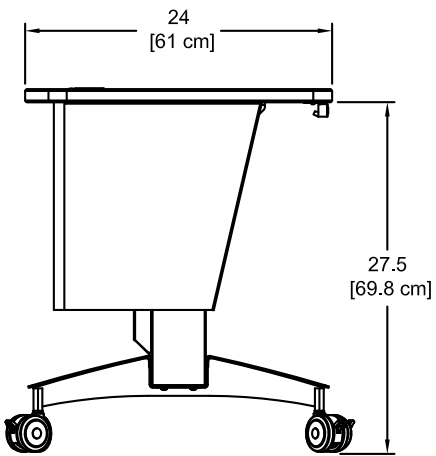
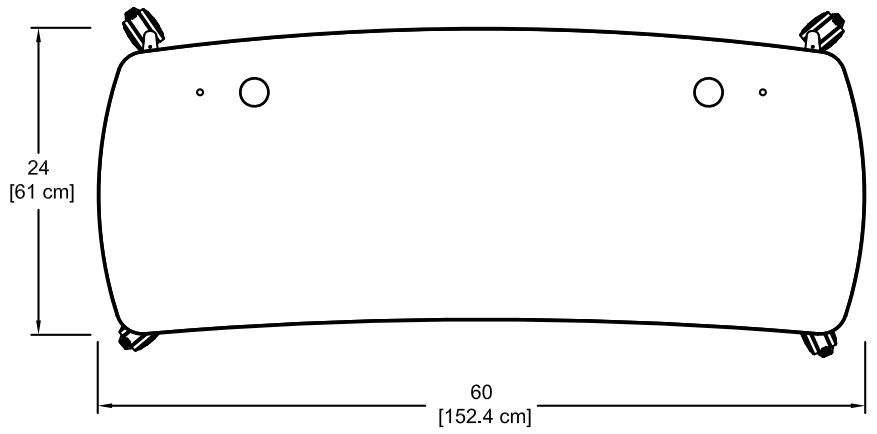
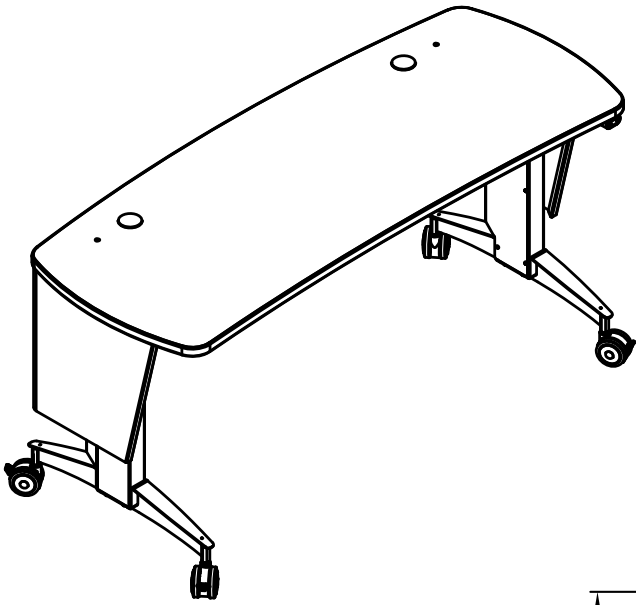

Max cutout area in worksurface
 (Optional keyboard tray, CPU slings,
 and rack rail shown in position)

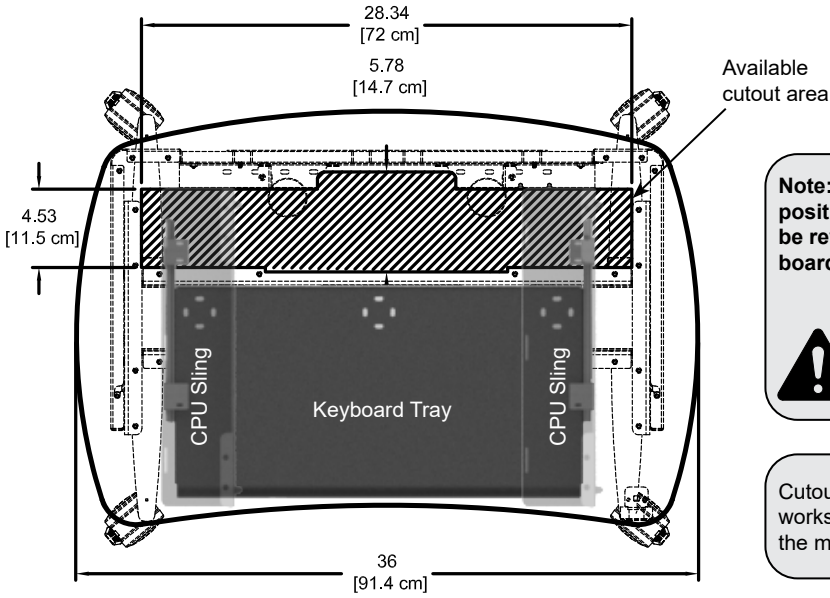

Note: Optional accessories (shown shaded) and their mounted position will effect final cutout locations. Custom cutouts should be reviewed by Spectrum to ensure clearance of brackets, keyboard slides, CPU slings, or other objects under the worksurface.

! Please contact Spectrum with preferred accessories and cutouts for assistance with worksurface cutout placement.

Cutouts can be made in the worksurface by the customer after the workstation has been purchased, but only are recommended within the maximum cutout area shown.

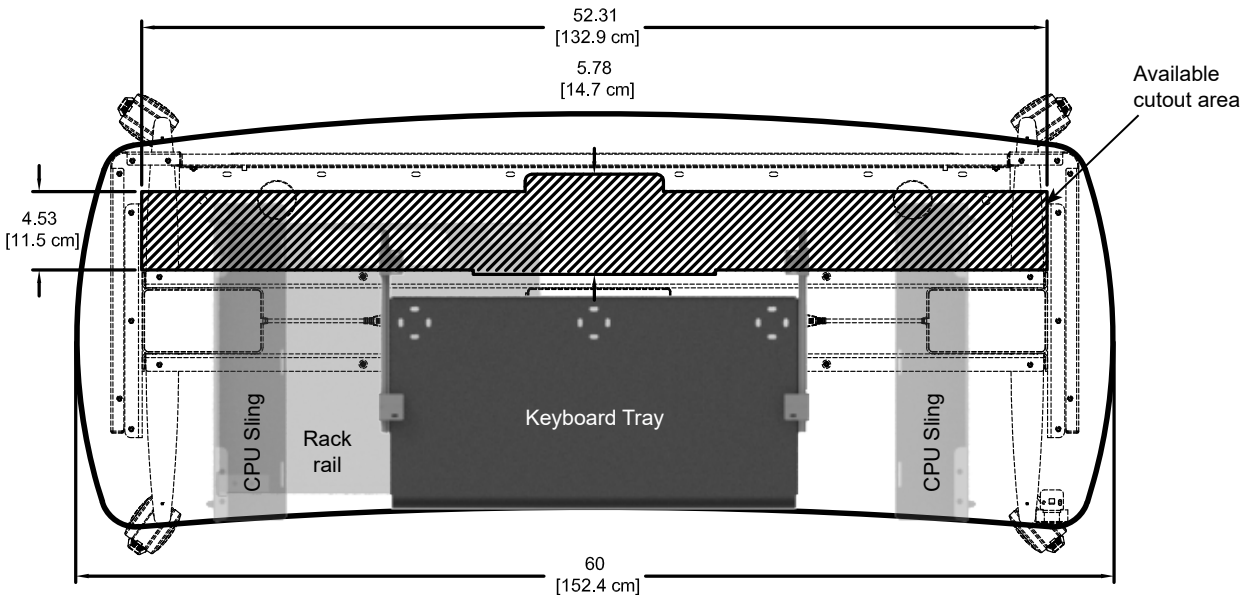
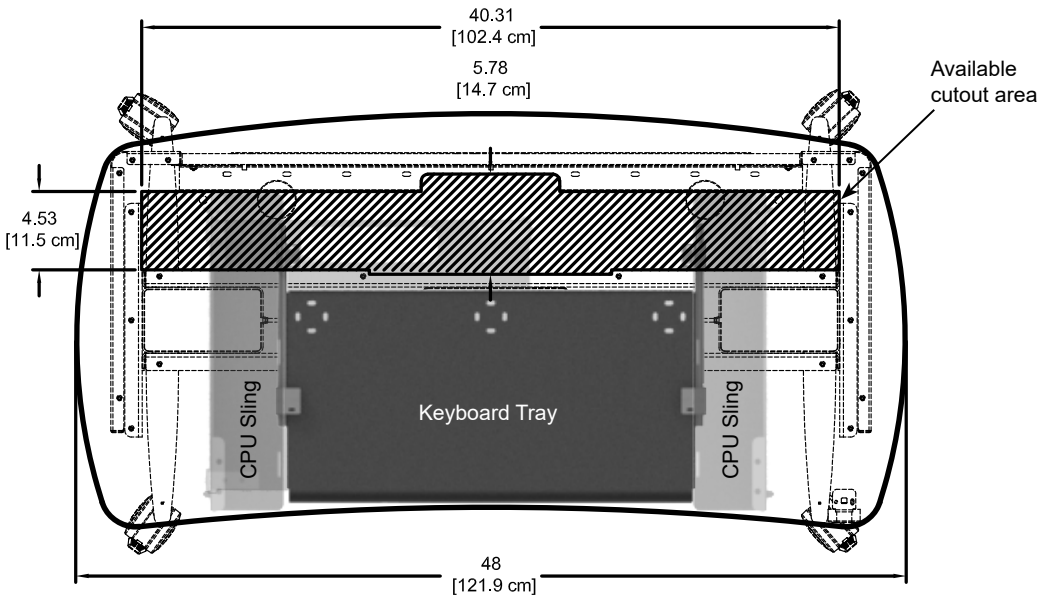

Common accessories and locations

36"W

Keyboard Tray

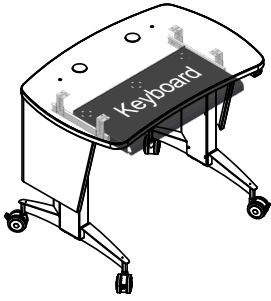

CPU sling

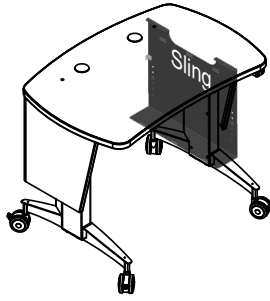

6RU Rack

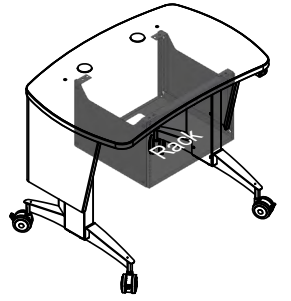

48"W

Keyboard Tray + CPU sling

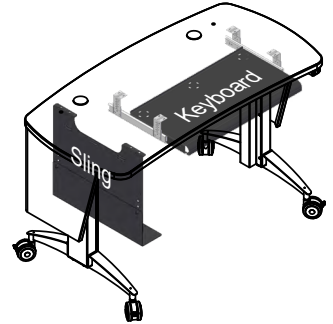
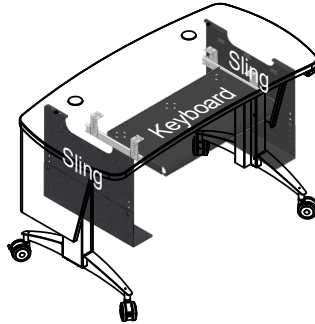
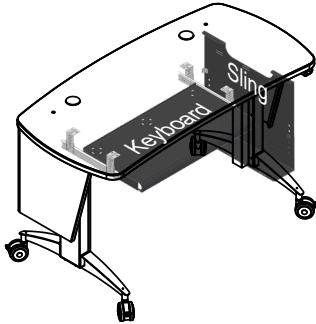

6RU Rack + CPU sling

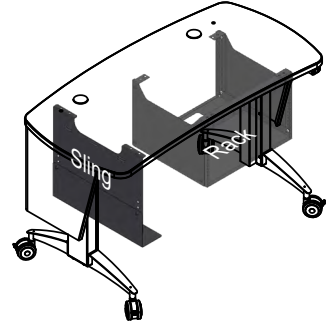
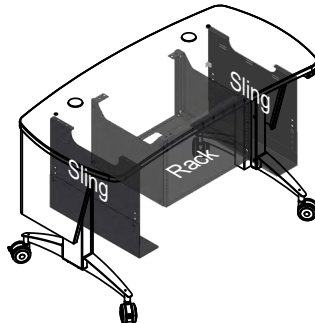
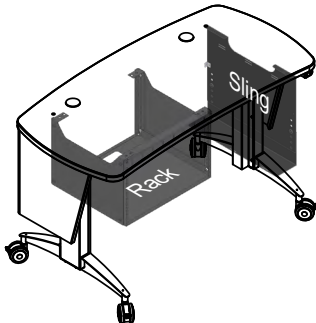

60"W

Keyboard Tray + CPU sling

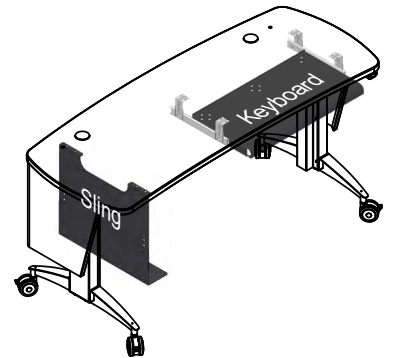
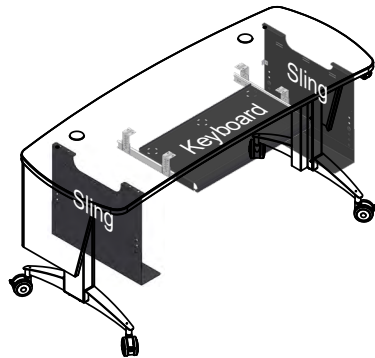
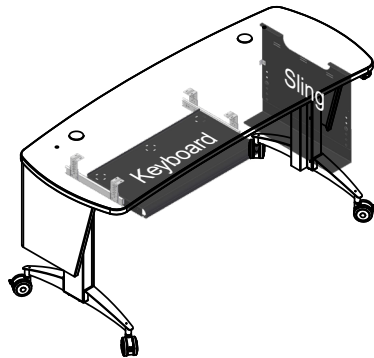

6RU Rack option + CPU sling

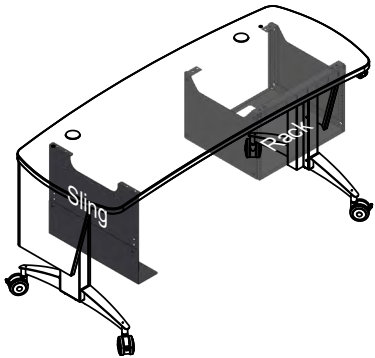
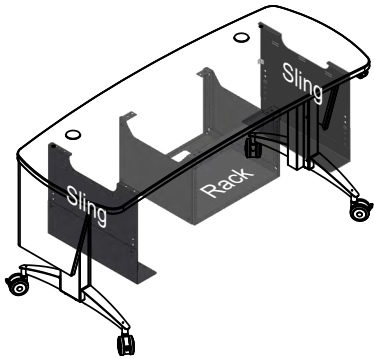

Keyboard Tray + 6RU Rack

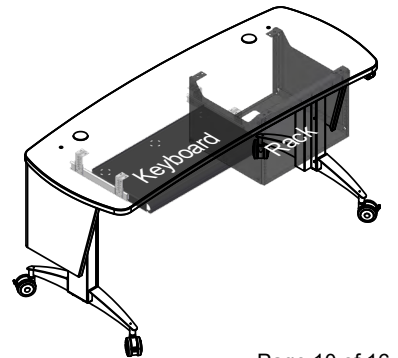

Accessories

Undermount AV Channel

- 95039 - for 36" Pivot Premier
- 95038 - for 48" Pivot Premier
- 95037 - for 60" Pivot Premier

Note: Undermount AV Channel is not compatible with an installed 95036 Undermount Rack Cabinet.

- Installs behind modesty panel (concealed)
- Slots provide multiple mounting options for AV over IP or other light AV electronics
- 2" side grommets simplify cable routing
- 20 ga steel
- Black powdercoat
- Customer assembled



95039 - for 36" Pivot Premier



95038 - for 48" Pivot Premier



95037 - for 60" Pivot Premier

Channel Dimensions: (D x H x W)	4" [10.2 cm] x 16" [40.6 cm] x 11" [27.9 cm]	4" [10.2 cm] x 16" [40.6 cm] x 23" [58.4 cm]	4" [10.2 cm] x 16" [40.6 cm] x 35" [88.9 cm]
Unit weight:	4.1 lb [1.9 kg]	6.2 lb [2.8 kg]	8.4 lb [3.8 kg] - (95037)
Shipping weight:	7.1 lb [3.2 kg]	9.2 lb [4.2 kg]	11.4 lb [5.2 kg] - (95037)

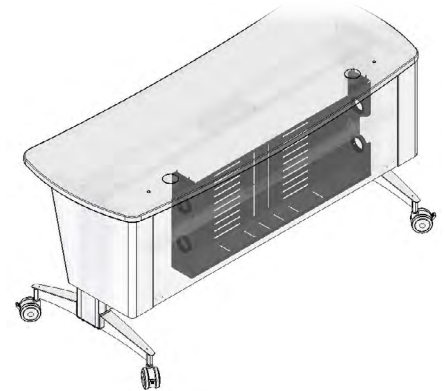
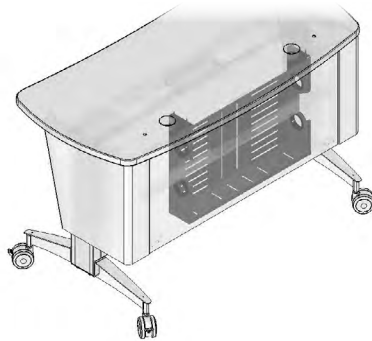
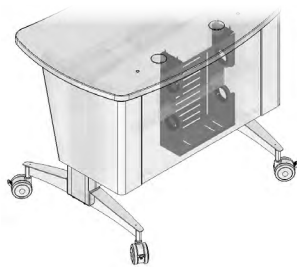

CPU Sling - 38982

- 4.25"W [10.8 cm] x 18.75"D [47.625 cm] x 14.125"-19.125"H [35.88 cm - 48.6 cm]
- 16 ga steel
- Black powdercoat
- Includes nylon straps
- Can be installed on left or right
- Unit weight: 7.5 lb [3.4 kg]
- Shipping weight: 8.5 lb [3.86 kg]

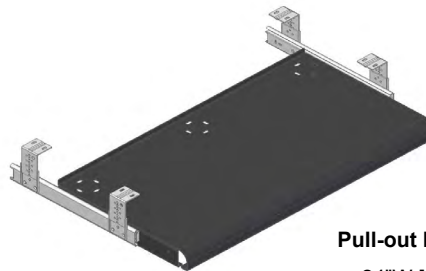

Pull-out Keyboard Tray - 55496

- 24"W [61 cm] x 11.625"D [29.5 cm] x 2.43"H [6.1 cm]
- 16 ga steel
- Shipping weight: 10 lb [4.5 kg]

Note: On the 48"W workstation, the keyboard tray is not compatible with the 95036 Undermount Rack Cabinet. On the 60"W workstation, the keyboard tray is compatible with (1) Undermount Rack Cabinet or (1) CPU sling.

Customized Metal Logo Panels

- Attaches to audience-side of lectern
- Available with black, white, or matching laminate backer
- New logos require a first time logo charge
- Customer-installed
- To get panel customized-contact Spectrum for details

**Customized Metal Logo Panel - 55111
(for 36" Pivot Premier Workstation)**

Dimensions:	18.5"W [47 cm] x 12"H [30.48 cm]
Available logo area:	16.5"W [41.91 cm] x 10"H [25.41 cm]
Unit weight:	2.35 lb [1 kg]
Shipping weight:	4.35 lb [1.97 kg]

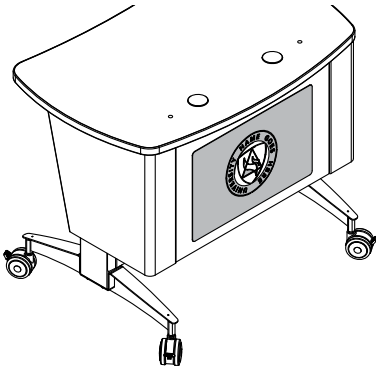

**Customized Metal Logo Panel - 55199
(for 48" and 60" Pivot Premier Workstations)**

Dimensions:	30"W [76.2 cm] x 12"H [30.48 cm]
Available logo area:	28"W [71.1 cm] x 10"H [25.41 cm]
Unit weight:	6 lb [2.7 kg]
Shipping weight:	8 lb [3.6 kg]

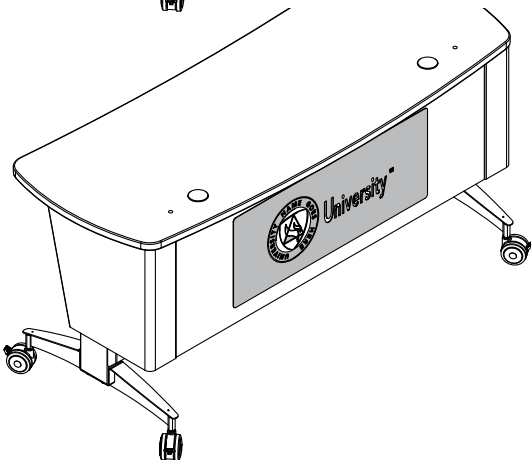
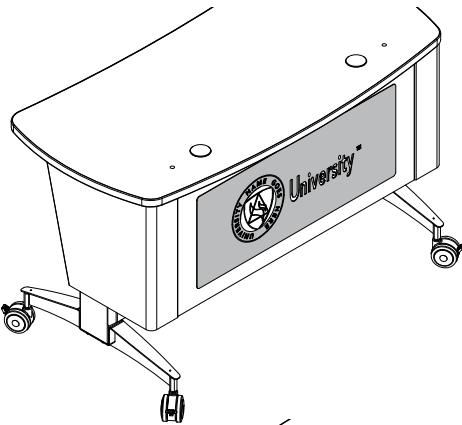

Customized Acrylic Logo Panels

- Attaches to audience-side of lectern
- Clear acrylic mounted on standoffs
- New logos require a first time logo charge
- Customer-installed
- To get panel customized-contact Spectrum for details

**Customized Acrylic Logo Panel - 55111
(for 36" Pivot Premier Workstation)**

Dimensions:	18.5"W [47 cm] x 12"H [30.5 cm]
Unit weight:	2.6 lb [1.2 kg]
Shipping weight:	3.6 lb [1.6 kg]

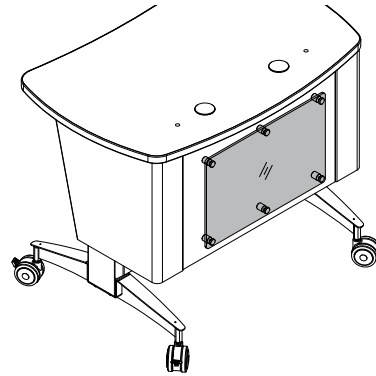

**Customized Acrylic Logo Panel - 55199
(for 48" and 60" Pivot Premier Workstations)**

Dimensions:	30"W [76.2 cm] x 12"H [30.5 cm]
Unit weight:	3.7 lb [1.7 kg]
Shipping weight:	4.7 lb [2.1 kg]

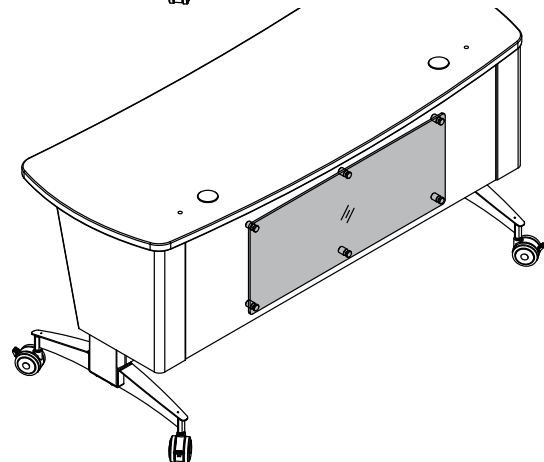
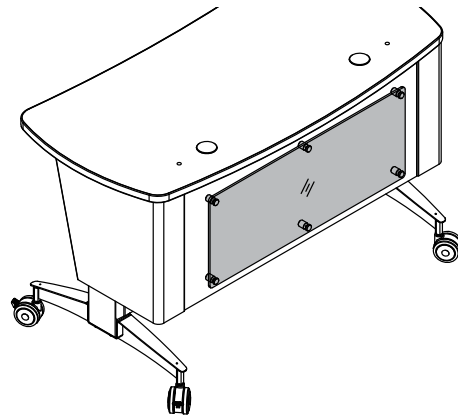

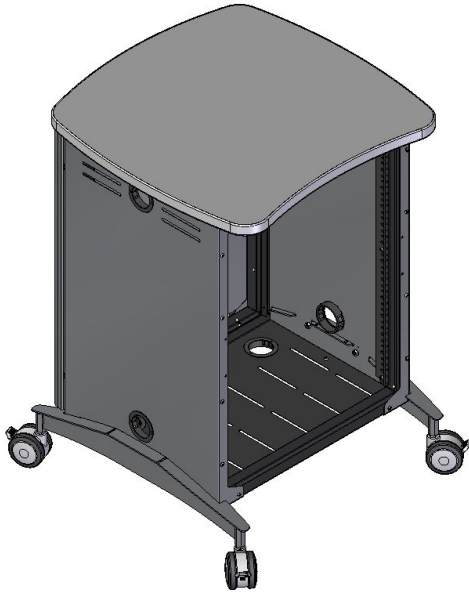

Companion Equipment Rack - 55559

- Freestanding rack provides 14RU on instructor-side (*Rear requires 68100 Rear Rack Rail Kit*)
- Locking casters provide mobility
- Standard rear door with matching laminate panel (non-acrylic)
- 2" side grommets provide easy cord routing
- Ventilated side and bottom panels keep equipment cool
- Available in same matching colors as Pivot Premier
- Customer-assembled

Overall Dimensions:	24"W [61 cm] x 24"D [61 cm] x 33.9"H [86.1 cm]
Rack units:	14RU
RU depth:	16"
Unit weight:	64.4 lb [29.2 kg]
Shipping weight:	94.4 lb [42.9 kg]

See compatible rack-mount accessories on next page

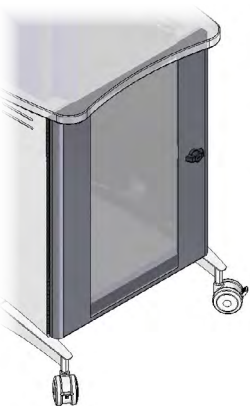
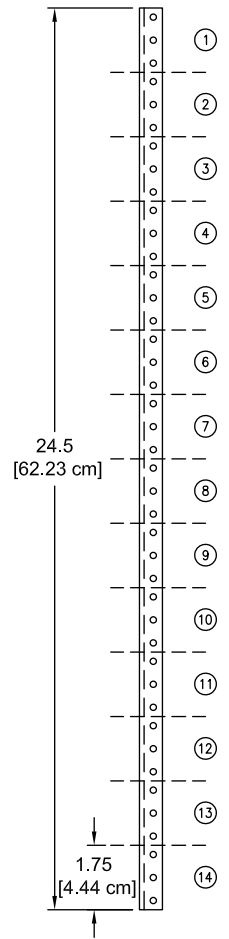
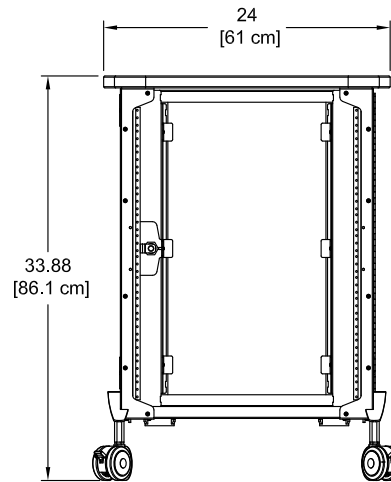
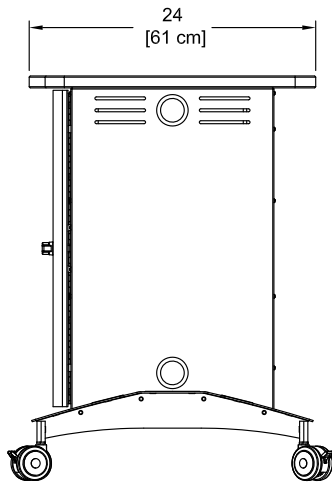
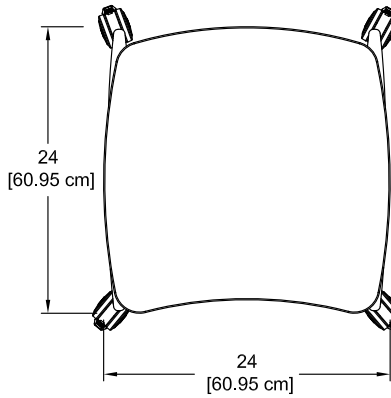

Acrylic Instructor-Side Door - 55560

- Installs on Companion Equipment Rack
- Single-point lock provides security
- Acrylic panel provides ability to monitor internal components
- Door can be installed to be hinged from the left or right
- Customer-installed
- Shipping weight: 10 lb [4.5 kg]

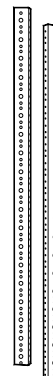

Rear Rack Rail Kit - 68100

- Adds 14RU to student-side of Companion Equipment Rack
- Set of 2
- Shipping weight: 3.2 lb [1.5 kg]

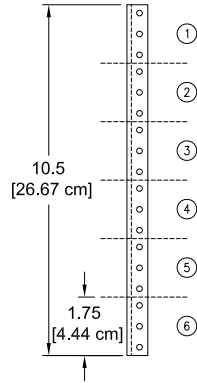
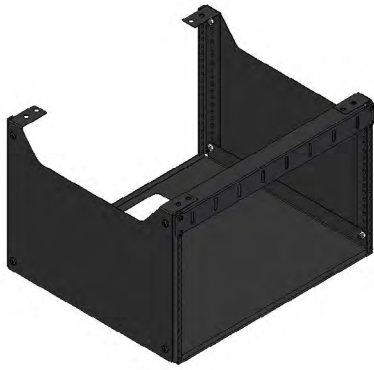

Undermount Rack Cabinet - 95036

- 19.2"W [48.8 cm] x 16.3"D [41.4 cm] x 12.5"H [31.75 cm]
- 6RU front and rear
- Accepts standard rack equipment up to 16.038"D
- Lower cutout for cable routing
- 20 ga steel
- Black powdercoat
- Customer assembled
- Shipping weight: 13 lb [5.9 kg]

See compatible rack-mount accessories below.

Note: The 95036 Undermount Rack Cabinet is not compatible with an installed Undermount AV Channel.

Rack-mount Accessories

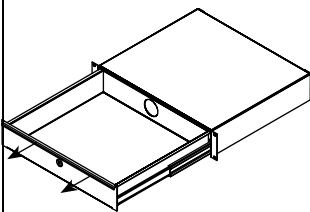

Locking Drawer - 2RU - 97527

- 16ga steel
- Drawer: 15.97"W [40.56 cm] x 14.56"D [36.98 cm] x 3"H [7.63 cm]
- Weight capacity: 50 lb [22.7 kg]
- Shipping weight: 15.85 lb [7.2 kg]

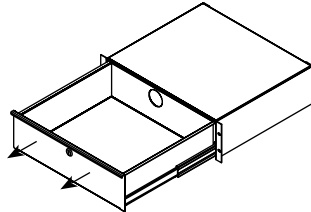

Locking Drawer - 3RU - 97526

- 16ga steel
- Drawer: 15.97"W [40.56 cm] x 14.56"D [36.98 cm] x 5.25"H [13.33 cm]
- Weight capacity: 50 lb [22.7 kg]
- Shipping weight: 18.5 lb [8.4 kg]

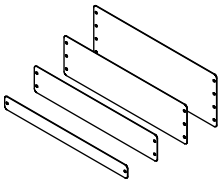

Rack-Mount Blanks

- 1RU - 97510 3RU - 97512
- 2RU - 97511 4RU - 97513

- Fills rack spaces where components are not needed
- 16 ga steel
- Shipping weight: <1 lb [45 kg]

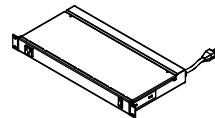

9-Outlet Power Strip - 1RU - 99021



- 8 outlets rear (breaker-protected)
- 1 convenience outlet front
- 115VAC, 60 Hz, 15 amps max
- 9' power cord
- Front LED power switch
- Enhanced surge protection
- ETL-listed, UL-listed
- 19"W [48.27 cm] x 9.25"D [23.5 cm] x 1.74"H [4.41 cm]
- Shipping weight: 8.7 lb [3.9 kg]

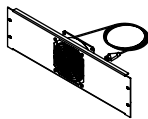

Single Fan - 3RU - 97507

- 50 cfm
- 120V~50/60 Hz, 15/13W
- RoHS
- 19"W [48.27 cm] x 1.56"D [3.97 cm] x 5.25"H [13.33 cm]
- Shipping weight: 3.78 lb [1.7 kg]

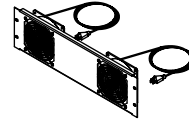

Double Fan - 3RU - 97506

- 100 cfm
- 120V~50/60 Hz, 15/13W
- RoHS
- 19"W [48.27 cm] x 1.56"D [3.97 cm] x 5.25"H [13.33 cm]
- Shipping weight: 5.47 lb [2.5 kg]



Wire Lace Kit - 95517

- Provides wire management
- Mounts to standard rack rails
- Includes (3) lace straps and mounting screws
- Includes (12) 5.5" zip ties
- Shipping weight: 1.25 lb [57 kg]

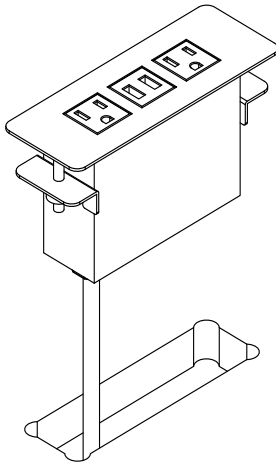

USB-C Power Module - 99075

- (2) AC power outlets (tamper-resistant)
- (1) USB charge port
- (1) USB-C charge port
- Aluminum housing and flange
- Thumbscrew clamps
- ETL-certified
- Available in black, silver, or white
- Customer-installed

Cutout required:	5.65"W x 1.65"D cutout exists under flip-up lid
Power cord:	10' [305 cm] 14AWG *3C power cord
Power receptacles:	125V, 60hz, 15A tamper-resistant
USB-C charging port:	2.4A (12W) (non data compatible)
USB charging port:	2.1A (10.5W) (non data compatible)
Dimensions:	6.38"W [16.2 cm] x 2.36"D [6 cm] x 3.54"H [9 cm]
Unit weight:	2 lb [.9 kg]
Shipping weight:	2.35 lb [1 kg]



Rechargeable Battery Pack System - 99045

- Creates a mobile workstation / desk by providing the ability to operate the unit in locations without AC power
- Compact, lightweight lithium-ion battery plugs into and charges from the existing workstation control box
- On-board LED light bars indicate charge capacity level
- Audio alarm signals when charging is needed
- Thermal switch protection, overcurrent protection
- Easy customer-installation

Battery Type	Lithium-ion
Capacity	2.2 Ah / 53 Wh
Voltage (nominal)	24V
Discharge current	9A (max)
Max charging voltage	40V DC
Charging current	0.5 A
Certifications	EN 62133 (Battery safety testing) UL 1642 (Lithium cells, standard test) UN 38.3 (Transportation of Lithium batteries) UL 2054 (Household and commercial batteries) EN 60335-1 with CBH Advanced
Unit weight: (nominal)	1.32 lb [.6 kg]
Shipping weight: (nominal)	2 lb [.9 kg]

Battery / Control Box Compatibility:

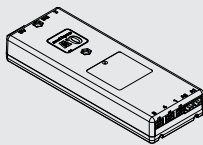

The CBD6S Linak control box is compatible with this battery pack.



Older CBD4 Linak control boxes are not compatible with this battery pack.



7-Outlet Power Strip - 99024

- Electrical Rating: AC 125V, 15 Amps
- 1000 Joules surge capacity
- 12' cord length
- LED switch
- UL Listed
- Shipping weight: 1.9 lb [.86 kg]



See spectrumfurniture.com for complete details on Spectrum's full line of monitor arms.

See spectrumfurniture.com for the latest accessories and detailed warranty information.

Warranty

We will make it right for you!

Thanks for choosing Spectrum! Spectrum is committed to provide complete customer satisfaction. Each of our products is manufactured from the best materials available and each product is stringently monitored throughout the production process through our P.A.C.E. program (Product Assurance to meet Customer Expectations).

We expressly warrant that Spectrum products will be of good quality and workmanship and free from defect for the period set out in the warranty from the date of delivery.

For a listing of all product specific warranty terms please visit our website at:

<https://www.spectrumfurniture.com/en/resources/purchasing-terms-warranty>

1-800-235-1262

Toll-free HELPLINE

spectrum@spectrumfurniture.com