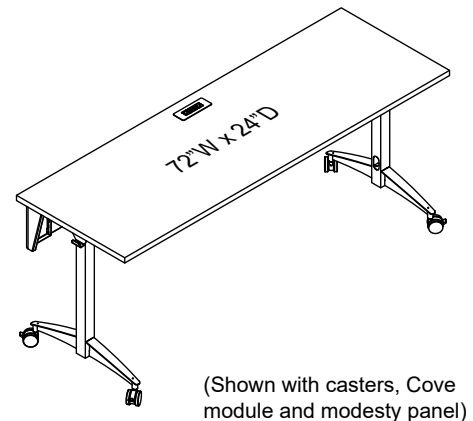
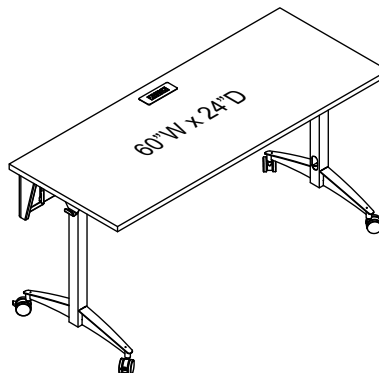
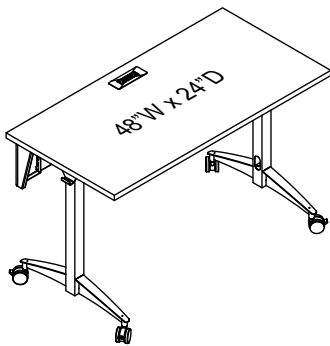
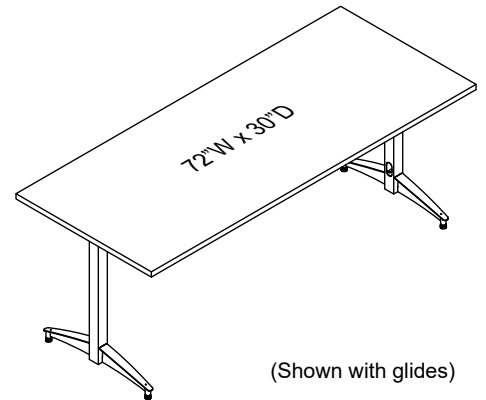
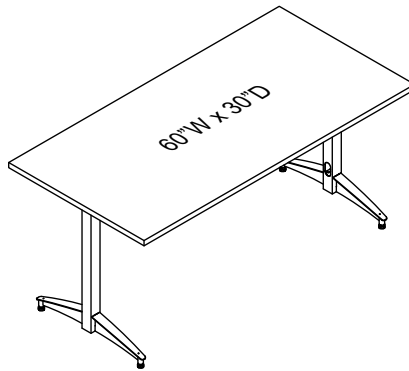
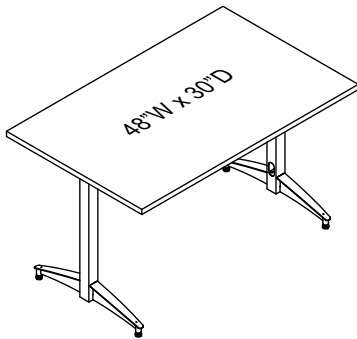


# Assembly Instruction

## Flex Active Table™

37239



### Important

Before using this product:

- Read this manual
- Comply with all safety and operating instructions
- Ensure all parts and correct quantities are included

Any parts damaged during shipment must be reported within 5 days of receipt. To report information regarding missing parts or damage, to purchase parts or accessories, or if you have any questions, please contact us.

*Thank you for purchasing Spectrum products!*

Spectrum Industries, Inc  
925 First Avenue, Chippewa Falls, WI 54729 USA  
800 235 1262  
715 723 6750  
[www.spectrumfurniture.com](http://www.spectrumfurniture.com)

## ⚠ Important Safety and Care Instructions ⚠

- Read this owner's manual before assembly or operation.
- Do not allow children to move the table.
- For indoor use only. Do not install or store the table where it will be exposed to moisture.
- Do not block the ventilation openings.
- Do not allow anyone to sit, stand, or climb on the table.
- Use a damp, soft-cloth, or sponge, with mild soap or detergent solution to clean dirty surfaces. **Do not use harsh solvents or abrasives.**
- This table is intended for institutional use. It does not have any user-serviceable parts or user-maintenance requirements. If servicing is necessary, please contact Spectrum Industries for assistance.

**⚠ Warning** - Relocating audio and/or video equipment to furniture not specifically designed to support audio and/or video equipment may result in death or serious injury due to the furnishing collapsing or over turning onto a child.

**⚠ Warning** - Death or serious injury may occur when children climb on audio and/or video equipment furniture. A remote control or toys placed on the furnishing may encourage a child to climb on the furnishing and as a result the furnishing may tip over on to the child.

### General Electrical Safety:

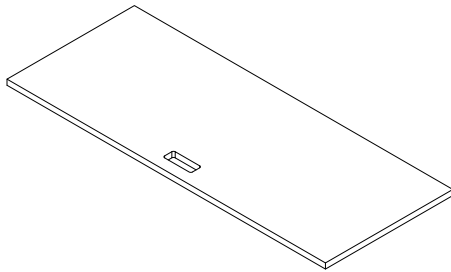
- Keep power switches in the OFF position before plugging or unplugging from the wall outlet.
- Be sure total device / equipment load does not exceed 12-amps.
- Do not plug power cords into an extension cord.
- Inspect power cords for damage before each use. Do not use cords that are damaged.
- Unplug power cord from electrical outlet by gripping the cord-do not unplug by pulling only on the cord.
- Do not step on, drive over, drag, or place objects on power cords.
- For added safety, plug into a grounded outlet controlled by a GFI (Ground Fault Interrupter) circuit breaker.
- Damaged electrical components can create significant hazards to users and is not covered by the warranty. Repairs should always be performed by a qualified electrician.
- Electrical devices are not toys. Children are often unaware of the hazards associated with electrical devices. This table must always be used by adults or with adult supervision.

## Components

Note: Depending on configuration ordered, not all components below may be included.

### Worksurfaces

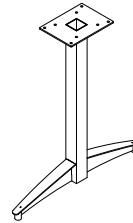
(1) Worksurface



Sizes:

48"W X 24"D  
 48"W X 30"D  
 60"W X 24"D  
 60"W X 30"D  
 72"W X 24"D  
 72"W X 30"D

### Legs

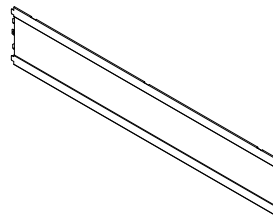


(2) T-Leg assembly

Glide-length:	Caster-length:
0151160	0151178

### Modesty Panels (Optional)

(1) Modesty panel



Panel only:	with insert panel:
0135610 - 48"W	0135611 - 48"W
0133637 - 60"W	0133642 - 60"W
0134280 - 72"W	0134281 - 72"W



(1) 0133632  
Right Corner



(1) 0133629  
Left Corner



(11) 026073  
#8 x 3/4" PHSM



(3) 0134099  
Mounting bracket

### Parts bag - Glides



(4) 037779  
5/16-18 Glide



(28) 0190419  
#14 x 1" PHSM

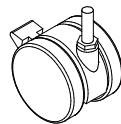


(2) 051070  
Half clip



(2) 026073  
#8 x 3/4" PHSM

### Parts bag - Casters



(4) 0105662  
5/16-18  
60mm Caster



(28) 0190419  
#14 x 1" PHSM



(2) 051070  
Half clip



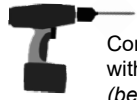
(2) 026073  
#8 x 3/4" PHSM

# Assembly / Setup



Phillips screwdriver

or



Cordless drill with Phillips driver (best)



1/2" wrench

## 1. Attach worksurface brace

1. Place the worksurface face down (laminite side-down) onto a flat, non-abrasive surface like another table. **Figure 1.**
2. Attach the worksurface brace with #14 x 1" PHSM screws.

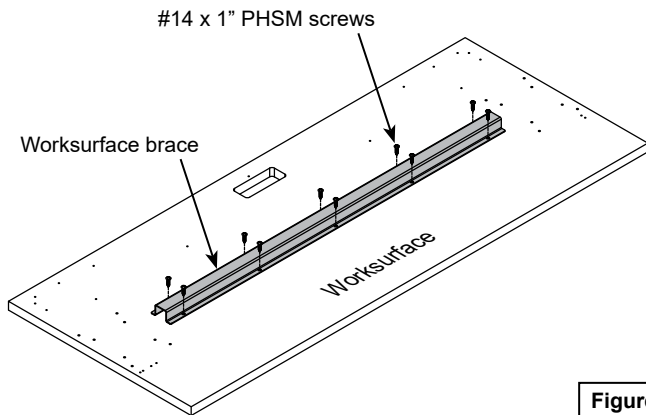


Figure 1

## 2. Install glides or casters

1. Thread the (4) glides or casters into the legs. **Figure 2.**

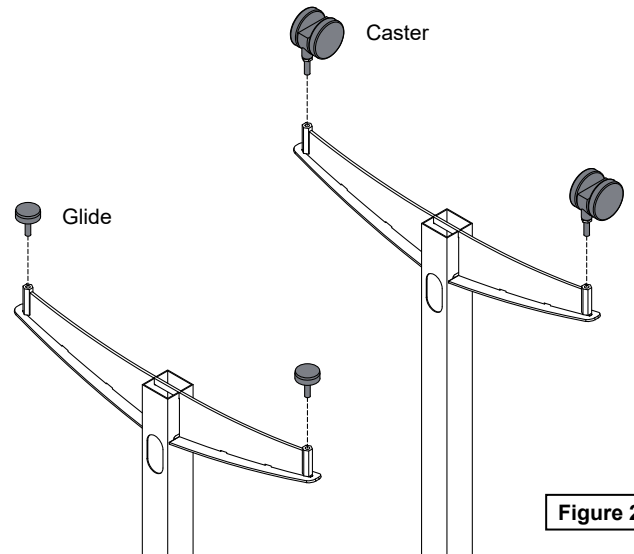


Figure 2

## 3. Attach legs to worksurface

1. Attach each leg as shown with (8) #14 x 1" PHSM screws. **Figure 3.1.**
2. If you have the optional backpack hangers, use (2) screws to attach each. **Figure 3.2.**

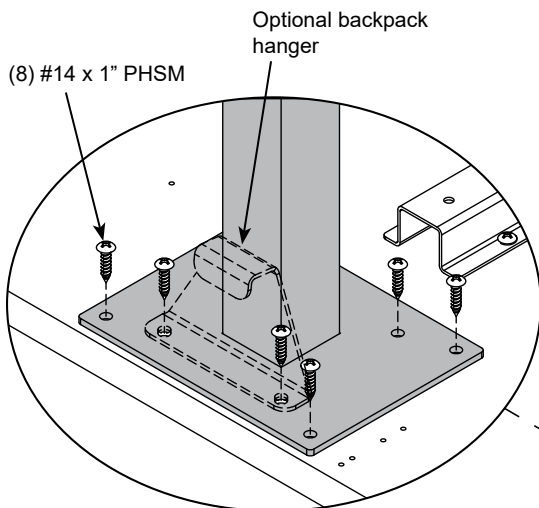


Figure 3.2

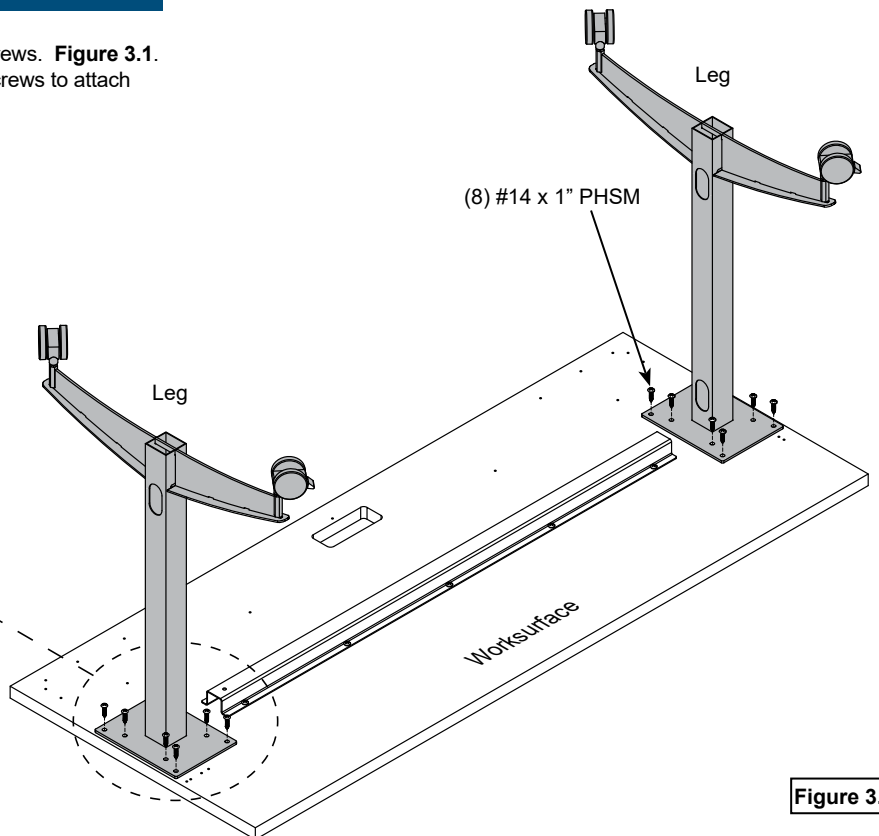
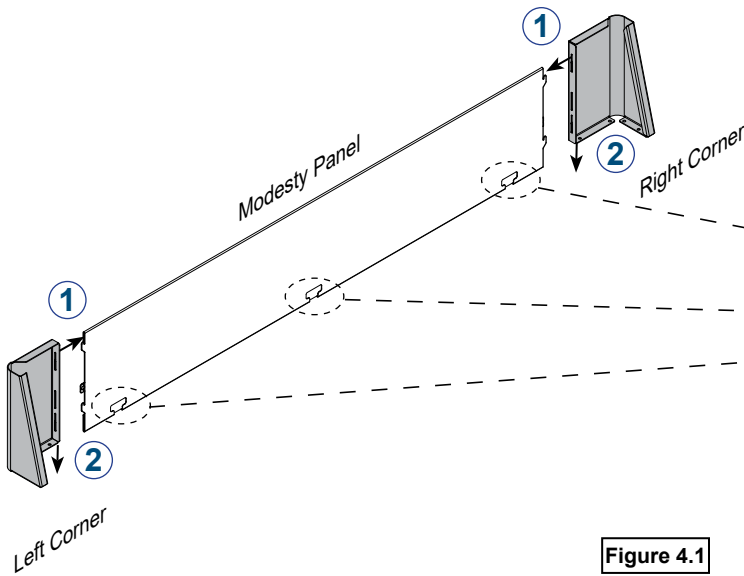


Figure 3.1

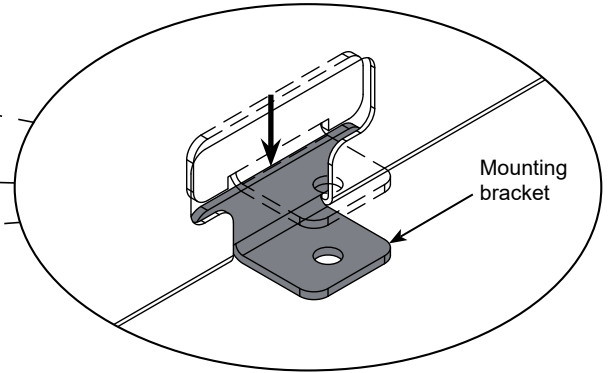
## 4. Install modesty panel - Optional

1. Orient the modesty panel and corners as shown and lock together.  
**Figure 4.1.**



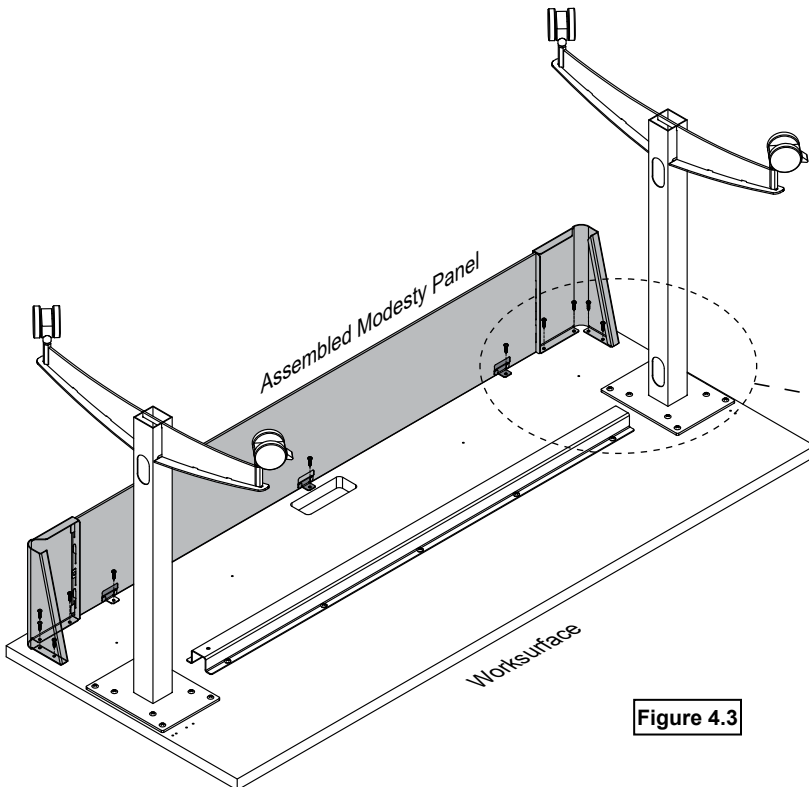
**Figure 4.1**

2. Place a mounting bracket inside each panel opening.  
**Figure 4.2.**



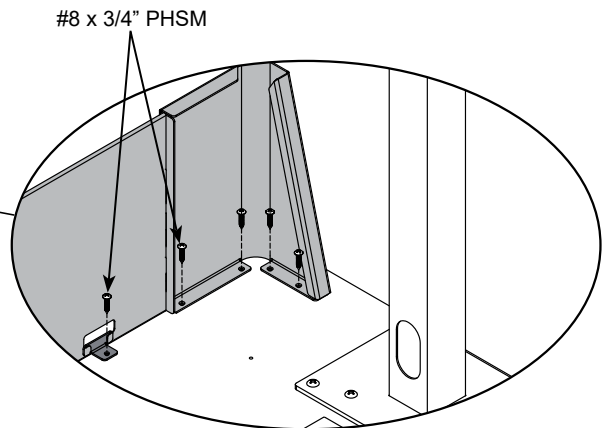
**Figure 4.2**

3. Align the modesty panel, bracket, and worksurface mounting holes.  
**Figure 4.3.**



**Figure 4.3**

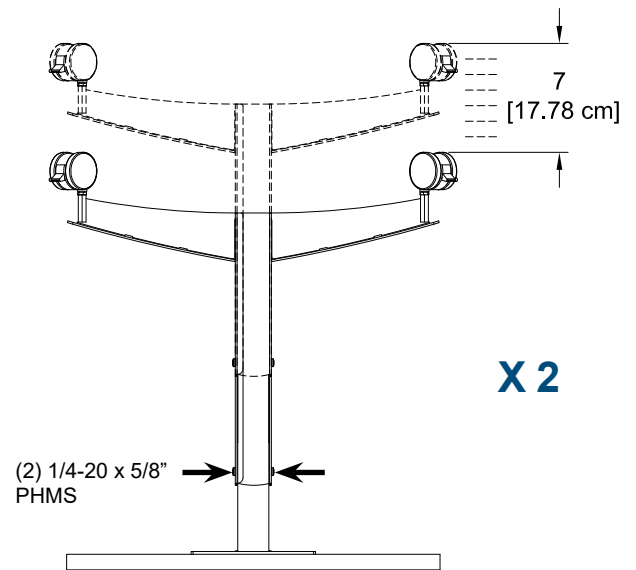
4. Attach to worksurface with (11) #8 x 3/4" PHSM screws.  
**Figure 4.4.**



**Figure 4.4**

## 5. Install modesty panel - Optional

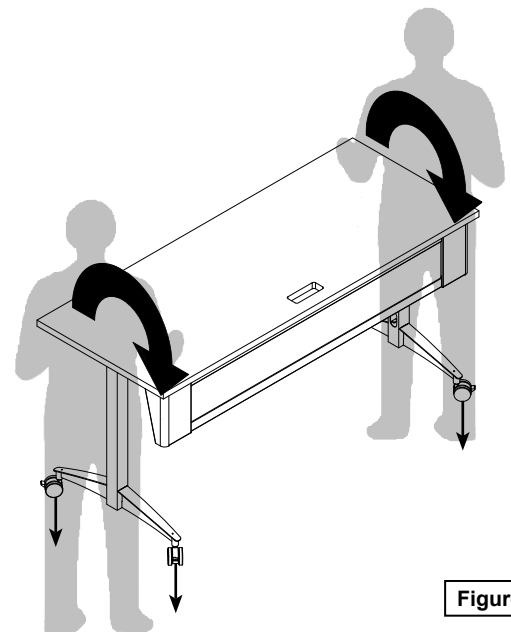
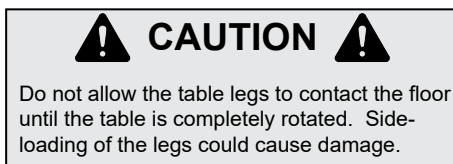
1. Orient the modesty panel and corners as shown and lock together. **Figure 5.**



**Figure 5**

## 6. Flip table upright

1. Carefully flip the table upright-this will take 2 people. **Figure 6.**



**Figure 6**

## Ganging latch installation - 37238 - Optional

1. Place two tables next to each other.
2. Open the latch and attach to table #1 with (2) #8 x 3/4" PHSM screws.  
**Figure 6.1.**
3. Attach keeper #1 to table #1 with (2) #8 x 3/4" PHSM screws.
4. Attach keeper #2 to table #2 with (2) #8 x 3/4" PHSM screws.
5. Tighten screws securely.
6. Close and lock latch to secure tables together. **Figure 6.2.**

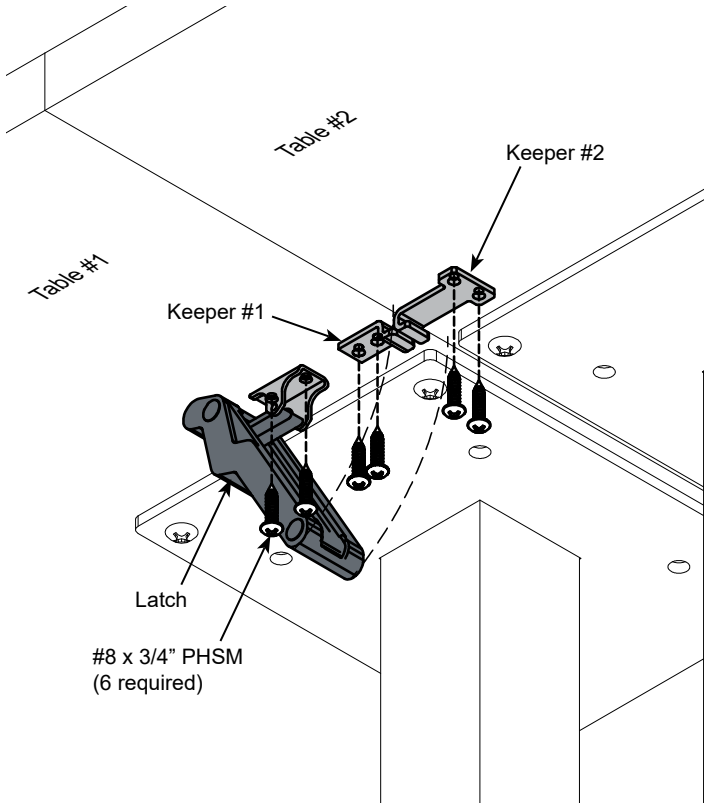
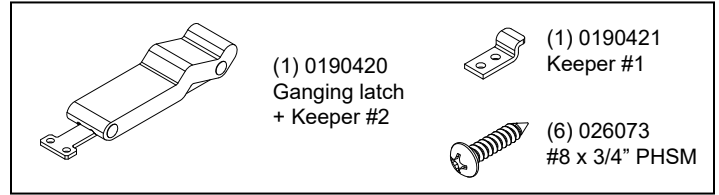


Figure 6.1

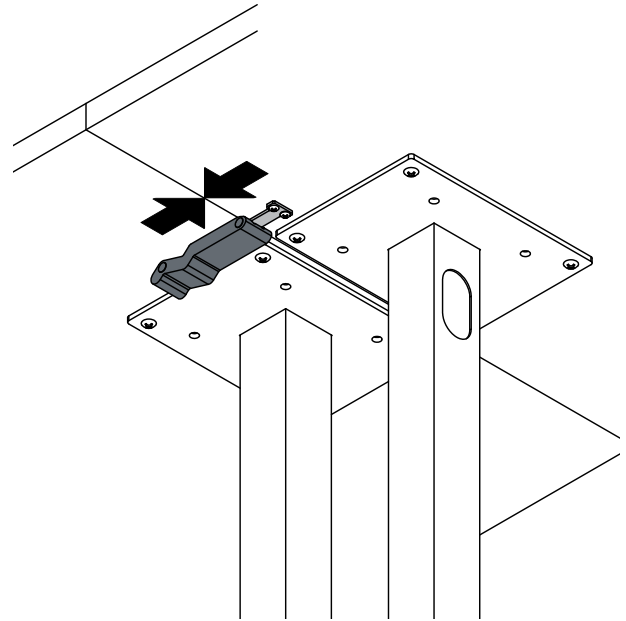
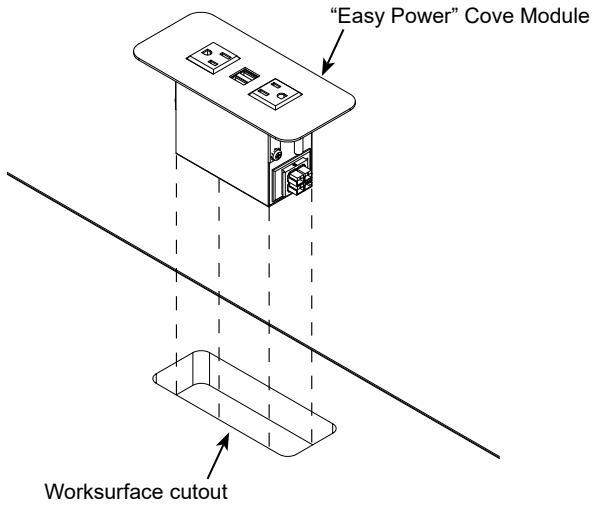


Figure 6.2

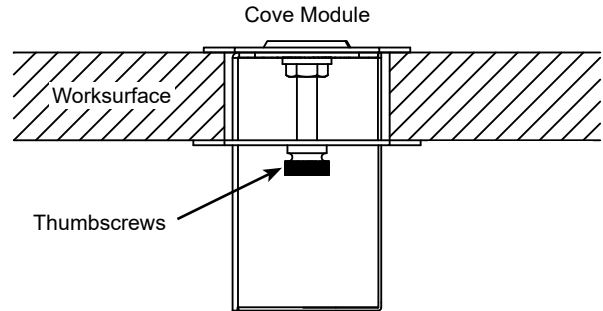
## “Easy Power Connection” installation - Optional

1. Remove locking tabs from the Cove module and place into the worksurface cutout. **Figure 7.1.**



**Figure 7.1**

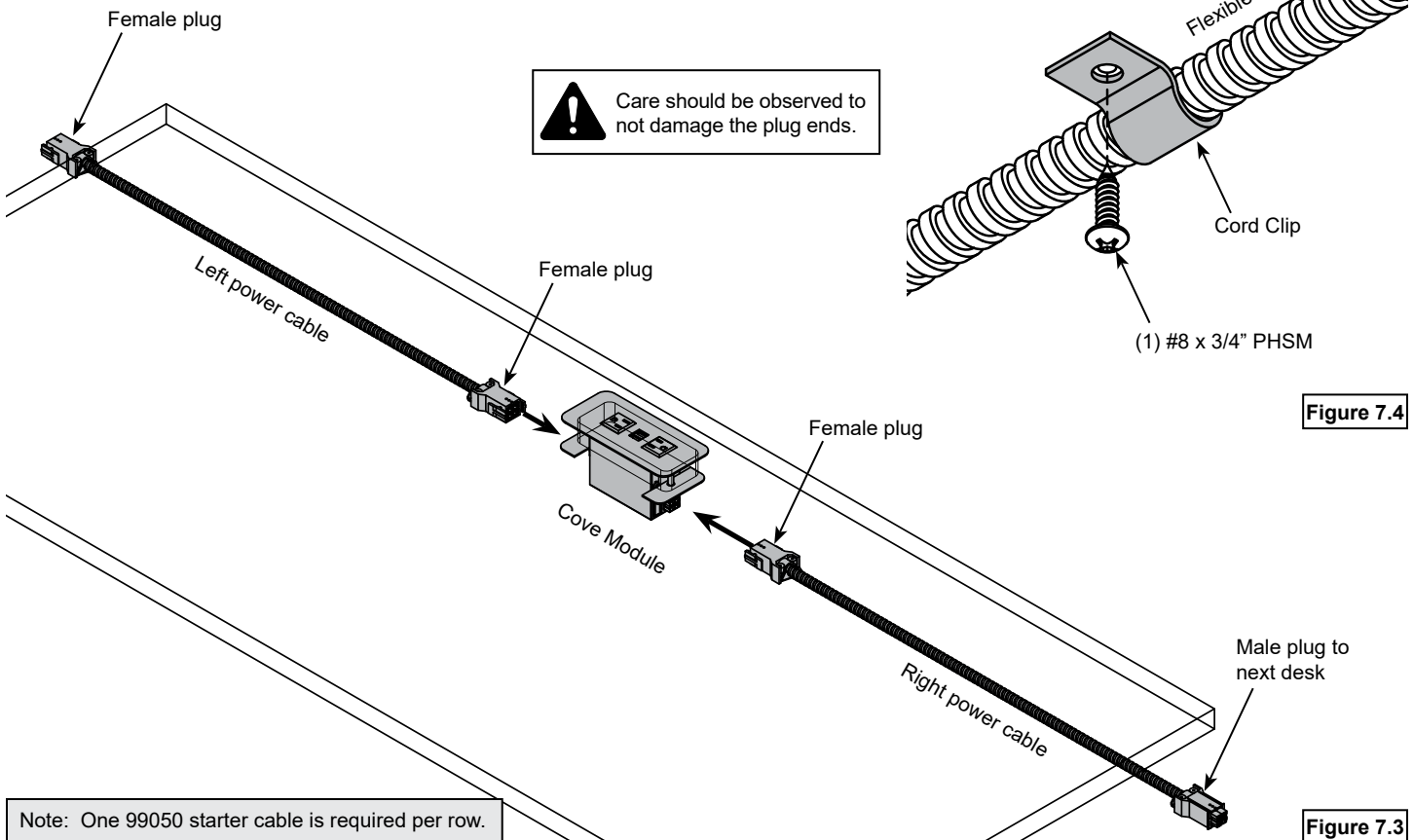
2. Replace locking tabs and secure with thumbscrews. **Figure 7.2.**



**Figure 7.2**

Note: Worksurface cutout is provided when configured.

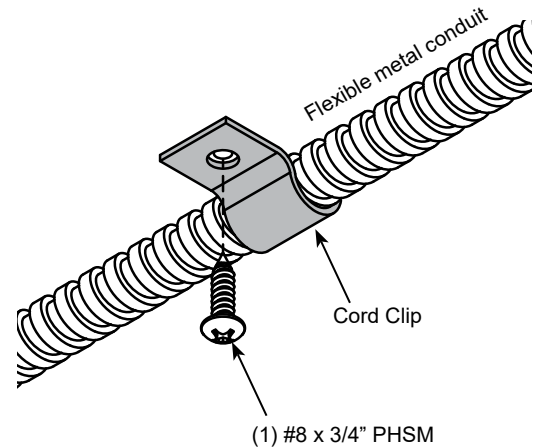
3. Plug the left and right power cables into the Cove module. **Figure 7.3.**



Note: One 99050 starter cable is required per row.

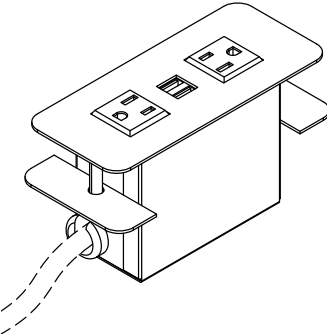
**Figure 7.3**

4. Install each cord clip with (1) #8 x 3/4" PHSM screw to secure the flexible metal conduit under the worksurface. **Figure 7.4.**
5. On tables near wall or floor outlets, the starter can be routed through the leg openings and down to the floor.

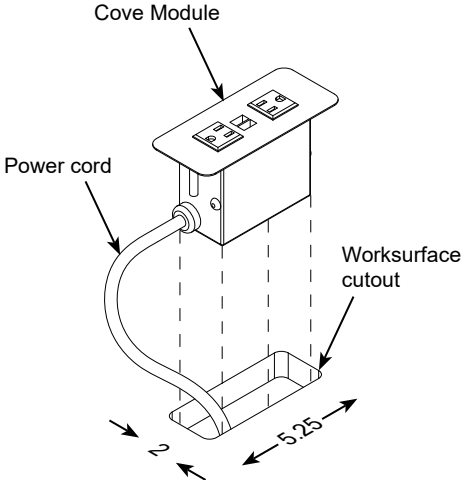


**Figure 7.4**

# Cove™ Power Module installation - Optional



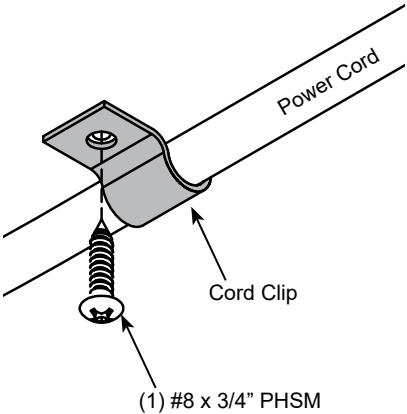
1. Remove locking tabs from the Cove module.
2. Insert the power cord through worksurface cutout and place the Cove module into the cutout. **Figure 8.1.**



**Figure 8.1**

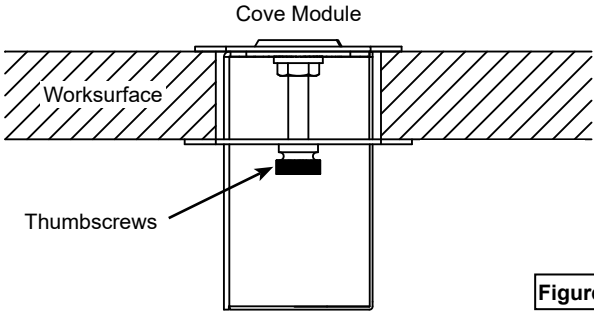
Note: Worksurface cutout is provided when configured.

4. Install each cord clip with (1) #8 x 3/4" PHSM screw and predrilled pilot hole to secure the power cord under the worksurface. **Figure 8.3.**



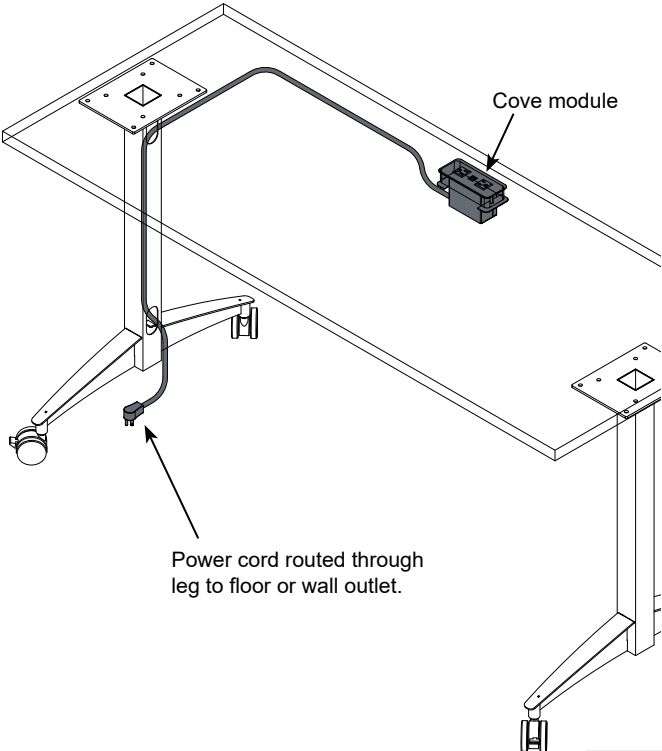
**Figure 8.3**

3. Replace locking tabs and secure with thumbscrews. **Figure 8.2.**



**Figure 8.2**

5. On tables near wall or floor outlets, the power cord can be routed through the leg openings and down to the floor. **Figure 8.4.**



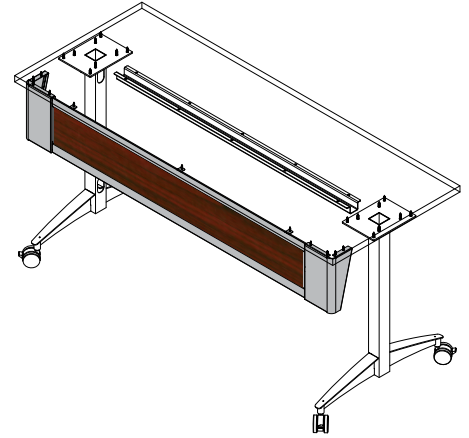
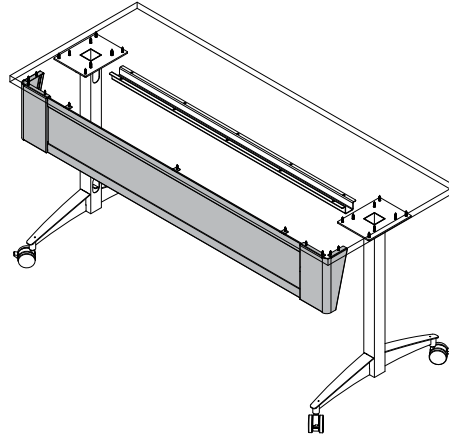
**Figure 8.4**



**Modesty Panel**

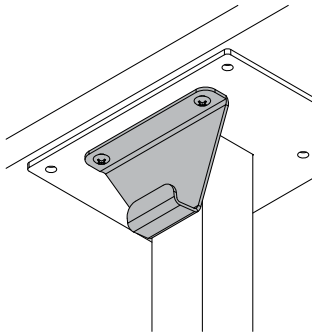
- 37234 - (for 48"W table)
- 37235 - (for 60"W table)
- 37236 - (for 72"W table)

- 16 ga steel
- 9"H panel attaches to worksurface
- Available with or without laminate insert
- Fasteners included



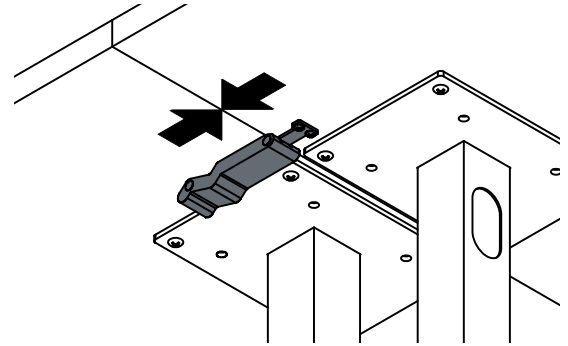
**Backpack Hanger - 37237**

- Includes two brackets
- Available in all metal colors
- 12 ga steel
- Each hanger bracket installs with (2) included screws
- Each Active Table supports up to two brackets



**Ganging Latch - 37238**

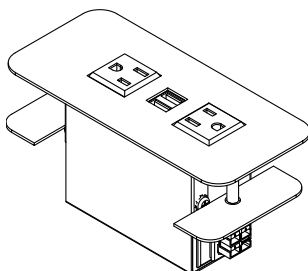
- Low profile and made of flexible rubber
- (1) Latch required per seam
- Fasteners included



**Cove™ Power Module with Easy Power Connection Kit**

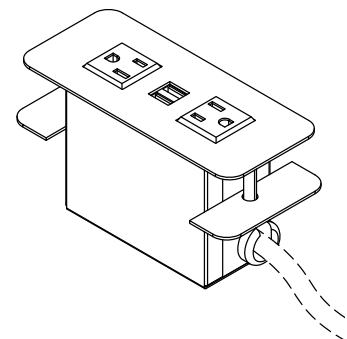
- 99047 - 48"W Table
- 99048 - 60"W Table
- 99049 - 72"W Table
- 99050 - Starter Kit (One required per row)

- Each table accommodates one power connection kit
- Two AC power receptacles
- Two USB charge ports (not data-compatible)
- Requires 5.25"W x 2"D worksurface cutout
- Flexible metal conduit is secured to worksurface underside
- Cove is ETL listed
- Thumbscrew clamps
- Cove available in Black or Silver
- Starter connects to standard 3-prong wall outlet



**Cove™ Power Module - 99044**

- Two AC power receptacles
- Two USB charge ports (not data-compatible)
- Thumbscrew clamps
- Requires worksurface cutout
- 9' AC power cord
- ETL listed
- Available in Black or Silver



See [spectrumfurniture.com](http://spectrumfurniture.com) for the latest accessories and detailed warranty information.

## Warranty

### **We will make it right for you!**

Thanks for choosing Spectrum! Spectrum is committed to provide complete customer satisfaction. Each of our products is manufactured from the best materials available and each product is stringently monitored throughout the production process through our P.A.C.E. program (Product Assurance to meet Customer Expectations).

We expressly warrant that Spectrum products will be of good quality and workmanship and free from defect for the period set out in the warranty from the date of delivery.

**For a listing of all product specific warranty terms please visit our website at:**

<https://www.spectrumfurniture.com/en/resources/purchasing-terms-warranty>

**1-800-235-1262**

Toll-free HELPLINE

**[spectrum@spectrumfurniture.com](mailto:spectrum@spectrumfurniture.com)**