

Technical Specifications

55153

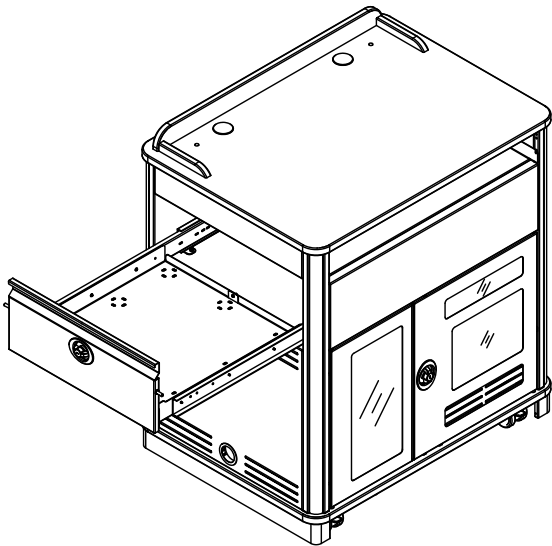

Media Manager Elite with surround, left drawer, rack cube installed on right

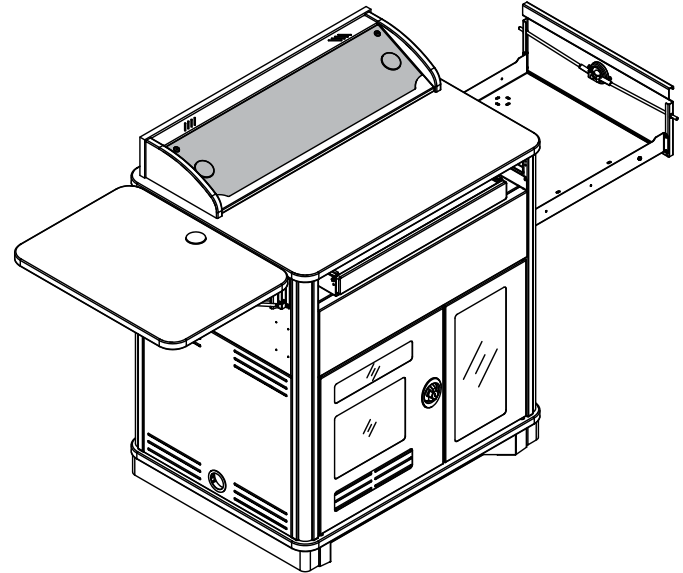

Media Manager Elite with overbridge, right drawer, rack cube installed on left, and toe kick, flip-up shelf on left

The Media Manager Elite is Spectrum's most popular lectern for college and university classrooms. It is the most practical lectern for the media-intensive classroom featuring a steel chassis with integral ventilation, a removable rack cube with front and rear access, and the largest locking document camera drawer in the industry. The Media Manager Elite is available in either left or right-hand drawer configurations. It is also easily customized with an Over-bridge Control Console for controllers, and laser cut logos to match any institution.

Features and Benefits

- Scratch and impact-resistant high-pressure laminate top provides a durable, useful worksurface
- Surround on worksurface provides privacy and styling
- Large locking pull-out drawer featuring inboard-mounted slides (200 lb rating) and wiring slots, provides secure document camera storage and a wrist-friendly writing surface (can be ordered on the left or right side)
- Pull-out keyboard tray with wiring slots can be used as a keyboard tray or storage drawer (supports large keyboards up to 19" wide with mouse)
- Overbridge version with blank panel allows custom cutouts and installation of electronics (overbridge version only)
- Worksurface grommet holes and cable grommets throughout lectern provide cable access
- Pre-drilled monitor arm mounting holes allow installation of a monitor arm (plain and surround versions only)
- 3" swivel Twin-Wheel (TW) casters provide mobility (2 locking)
- 2" grommet in each side panel provide cord access
- Cable grommets throughout provide cable access
- Internal wiring channel provides easy cable routing
- Integrated ventilation throughout lectern helps keep equipment cool
- Side panels available in metal or laminate.
- Primary and secondary instructor side acrylic doors provide monitoring of internal equipment, security, and can be removed via quick-release to provide full access to rack equipment. Doors can be attached on the left or right side of the lectern with minimal re-assembly.
- Primary door has double-bolt keyed lock.
- Optional removable cube rack-rail mounting (12RU) simplifies installation for any equipment configuration, provides mounting capabilities for multiple cooling fans.
- The rack cube provides the ability to integrate equipment remotely, then be installed into the left or right side of the lectern at a later date
- Removable audience-side panel provides access to internal equipment
- Optional toe kick panel with access panel is available when mobility is not necessary or required (requires wheels to be locked, can be anchored to floor) (customer-installed)
- Optional customizable logo panel simplifies adding or changing logos
- Optional flip-up shelf provides a convenient additional worksurface (mounts on side opposite document camera drawer)
- Durable powder coated steel chassis provides a long-lasting finish
- Warranted to be free of all defects in materials and workmanship for 10 years
- Designed and assembled in Chippewa Falls, WI, USA

Color Options

Available in Spectrum Expressions colors.  
See [spectrumfurniture.com](http://spectrumfurniture.com) for complete color information.

Ordering Instructions

Spectrum has designed this product to receive the useful options shown here. To ensure your options are ordered correctly please call 1-800-235-1262.

# Construction

- The worksurface is constructed from 1" thick composite board with .030" high-pressure laminate on one face, and a balancing phenolic backer on the opposing face
- Metal components consist of 16-gauge steel
- Worksurface edges are covered with 3mm vinyl edgeband
- All metal components are finished with a scratch-resistant powder coat epoxy
- Solid wood corner trim
- Each Media Manager Elite Lectern is factory-assembled with casters, packaged, and shipped on its own skid. Customer-installed base skirt.

# Specifications

Total lower internal area (nominal)	32.75"W [83.2 cm] x 26.12"D [66.4 cm] x 21.72"H [55.2 cm]
CPU area (nominal)	12.4"W [31.5 cm] x 26.12"D [66.4 cm] x 21.72"H [55.2 cm]
Keyboard tray	22"W [55.9 cm] x 13.75"D [35 cm] x 2"H [5.1 cm]
Optional Rack cube	12RU
3" Twin Wheel casters	Weight capacity 165 lb [74.9 kg] each
Document Camera Drawer	<ul style="list-style-type: none"> <li>• Internal dims: 23"W [58.4 cm] x 21.5"D [54.6 cm] x 6.22"H [15.8 cm]</li> <li>• 200 lb [90.8 kg] rated slides</li> </ul>
Certifications / Compliance	<ul style="list-style-type: none"> <li>• Meets or exceeds applicable ANSI-BIFMA test standards</li> </ul>
Unit weight (nominal)	261 lb [118.5 kg] (with surround) 266 lb [120.8 kg] (with overbridge)
Shipping weight (nominal)	368.5 lb [167.3 kg]

Specifications subject to change without notice

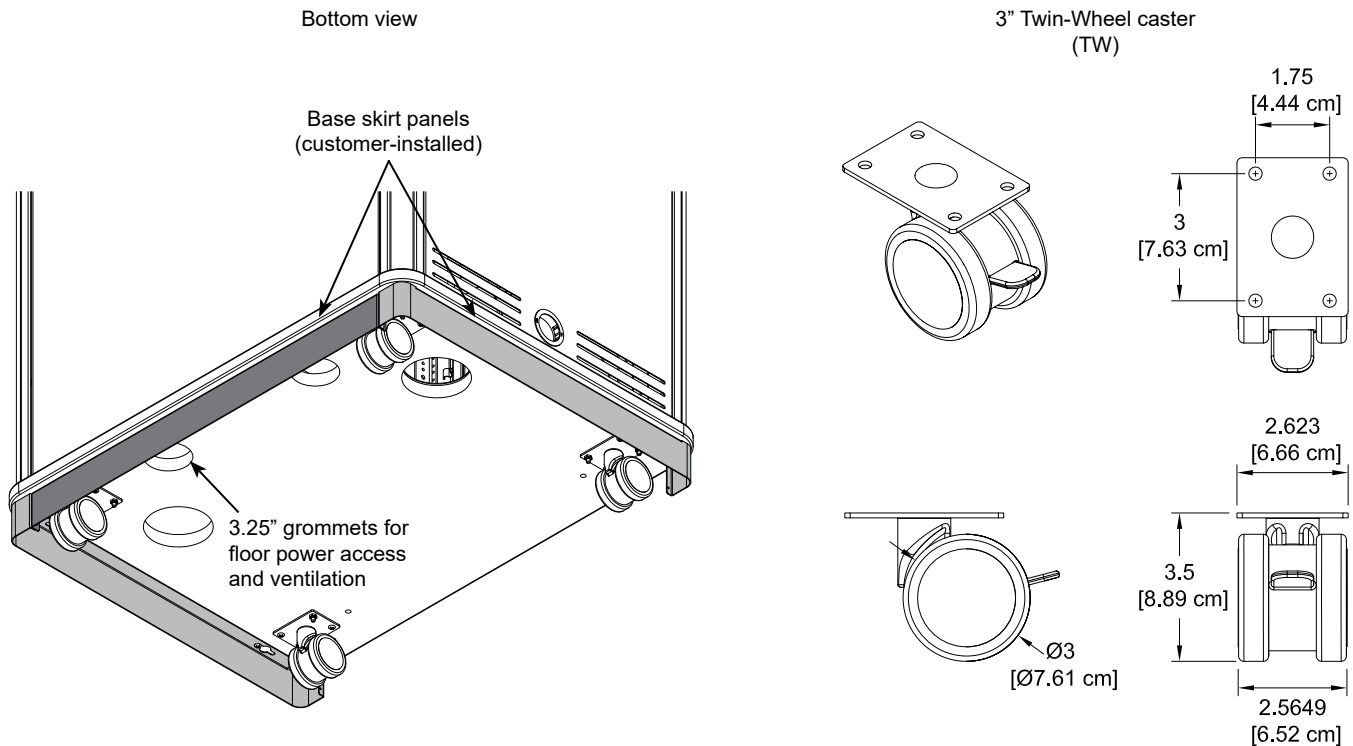

**Heat Dissipation:**

- The passive heat dissipating system of this lectern is sufficient for up to approximately 800 BTU's of internal heat. Anything higher may require a forced air system.
- If a forced air system is anticipated, a rack mounted intake fan can be installed directly behind the instructor-side vented door panel to draw air into the rack space.
- The two 3.25" wire management grommet caps in the base panel can also be removed to increase airflow.

<b>ORDER CODE P1 =</b>	Plain worksurface
<b>ORDER CODE P2 =</b>	Plain worksurface-custom

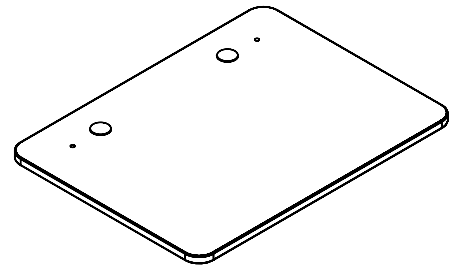

<b>ORDER CODE S1 =</b>	Surround worksurface
<b>ORDER CODE S2 =</b>	Surround worksurface-custom

- Surround
- Two 2" grommets (with covers)
- Two .375" holes (with plugs) for worksurface monitor arm mounting

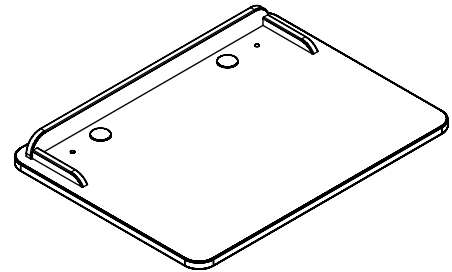

<b>ORDER CODE B1 =</b>	Overbridge Control Console™ - Full panel-blank
<b>ORDER CODE B2 =</b>	Overbridge Control Console™ - Full panel-custom cutouts

- Overbridge with blank insert panel for custom cutouts (see p.4 for dimensions). (Overbridge not available separately)
- Two 2" grommets (with covers)

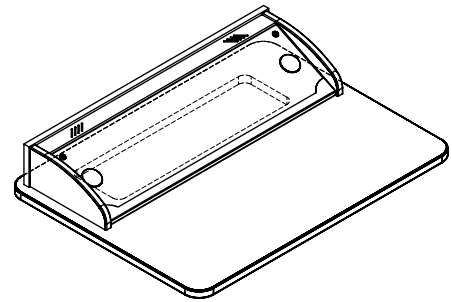

<b>ORDER CODE B3 =</b>	Overbridge Control Console™ - Split panel-blank
------------------------	---

- Overbridge with split blank insert panel (see p.4 for dimensions). (Overbridge not available separately)
- Two 2" grommets (with covers)

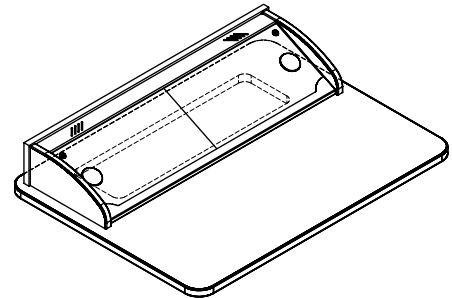

**Custom cutouts by Spectrum**

- Contact Spectrum to specify cutout size(s) and location(s)
- See recommended cutout areas (shaded)

**\*When ordering a lectern with cutouts, specify complete details of the device(s) (brand, model number, cutout size, quantity, etc.) to the Spectrum sales rep when ordering.**

Spectrum can provide cutouts exactly matching any commercially available data and electrical power outlet, but are only recommended within the maximum cutout areas shown. Cutouts should be reviewed by Spectrum to ensure clearance of brackets, keyboard slides, or other objects under the worksurface.

Cutouts in blank worksurfaces can be made by the customer after the lectern has been purchased, but are only recommended within the cutout areas shown.

Overbridge panel cutout area

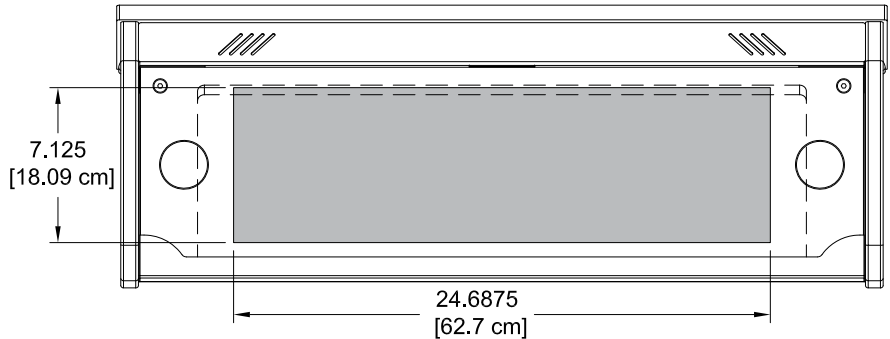

Worksurface cutout area

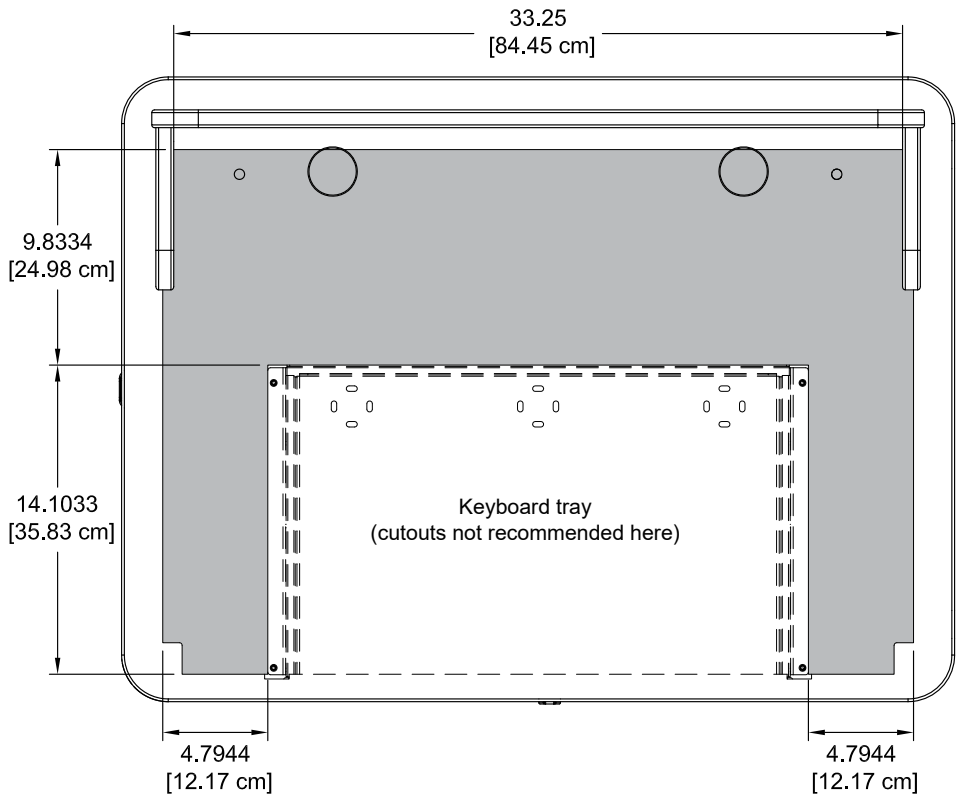

Note: Spectrum Industries, Inc. manufactures furniture that supports a wide variety of power and communication devices from a variety of manufacturers. This table is compatible with many Extron, Crestron, Altinex, AMX, and other devices. Spectrum does not resell these products; please consult your electronic supplier for the equipment that best suits your needs. Size specifications from the manufacturer can be used to verify the fit.



**Note: Some controllers and devices require additional space around the cutout for clamping under the worksurface. Please double check your device specifications to ensure adequate space around the cutout.**

**ORDER CODE 0 = None**

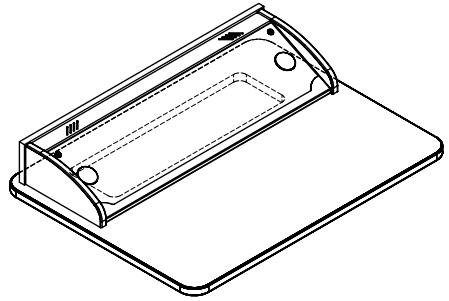
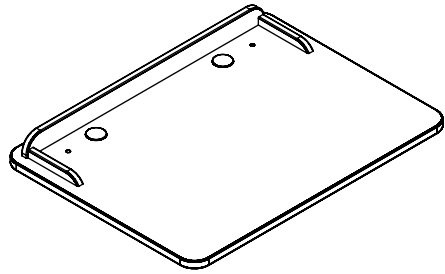

**ORDER CODE 1 = w/ Power Module - Black**

**ORDER CODE 2 = w/ Power Module - Silver**

**ORDER CODE 3 = w/ Power Module - White**

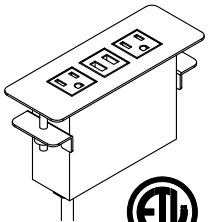

See p.17 for more information

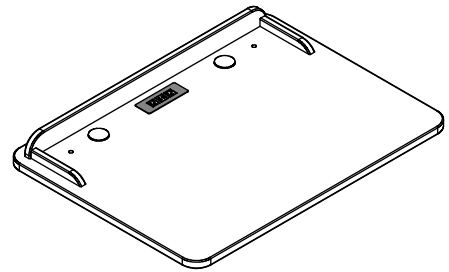

Note: Power module not available on overbridge version.

**ORDER CODE 4 = w/ Power Module - Black & EM Wireless Charging Pad**

**ORDER CODE 5 = w/ Power Module - Silver & EM Wireless Charging Pad**

**ORDER CODE 6 = w/ Power Module - White & EM Wireless Charging Pad**

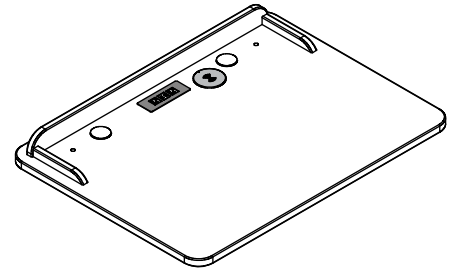
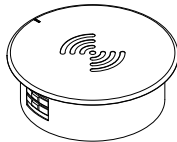
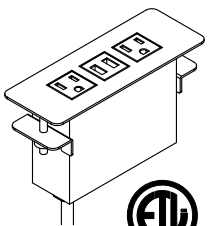

Note: Power module not available on overbridge version.

**ORDER CODE 7 = EM Wireless in worksurface**

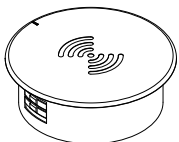

See p.17 for more information

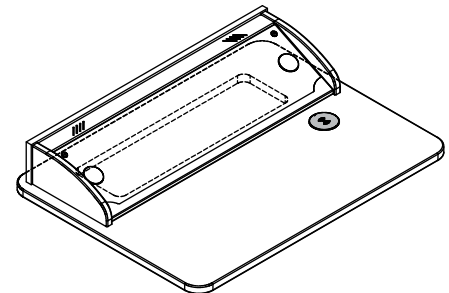
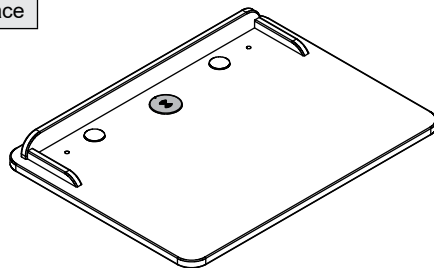

<b>ORDER CODE 0 =</b>	None
-----------------------	------

<b>ORDER CODE C =</b>	1 Flip-up shelf (matching laminate)
<b>ORDER CODE D =</b>	2 Flip-up shelves (matching laminate)
<b>ORDER CODE E =</b>	1 Flip-up shelf (Chalk white dry erase)
<b>ORDER CODE F =</b>	2 Flip-up shelves (Chalk white dry erase)

Note: 2 flip-up shelves only work on lecterns configured without a drawer.

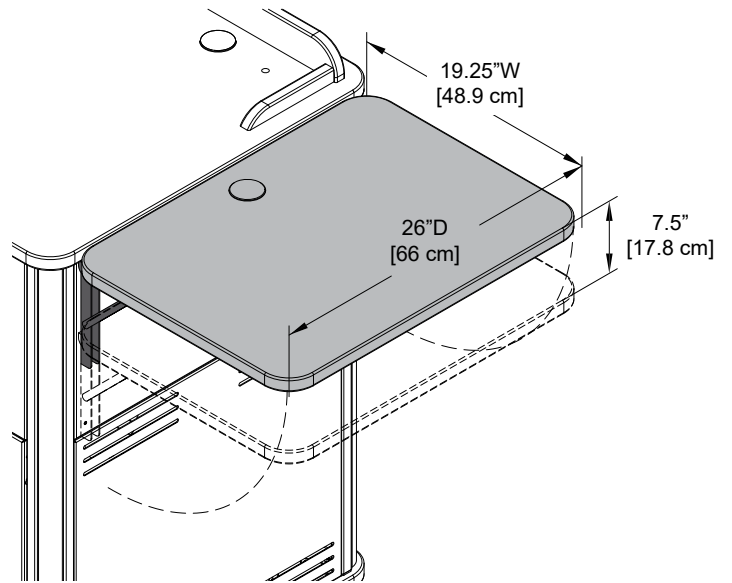

- Installs on side opposite drawer
- Shelf hinges lock into place in the upright position
- Includes 2" grommet
- Two height-positions available
- Available in White Chalk Dry Erase laminate. Flip-up shelves configured with white laminate will have the same edgeband color as the worksurface and base panel.
- Customer-installed on side opposite drawer. Can be installed in upper (level with worksurface), or lower position.

Weight capacity:	35 lb [15.9 kg]
Dimensions:	19.25"W [48.9 cm] x 26"D [66 cm] x 1"H [2.54 cm]
Height positions available:	41"H [104.1 cm] (level with worksurface) 33.5"H [85.1 cm]
Shipping weight:	21 lb (9.5 kg)

Note: Power and communication wiring for document cameras, laptop computers, and/or projectors placed on the flip-up shelf should be routed on top of the audience-side of the shelf. Use of the shelf grommet hole for wiring will result in pinching of the cords when the shelf is folded.

**Metal Side Panel**

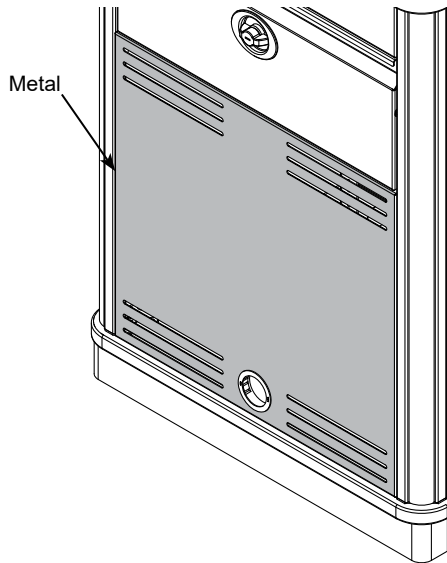

Ventilation: Metal panel has integrated vents.

**Laminate Side Panel**

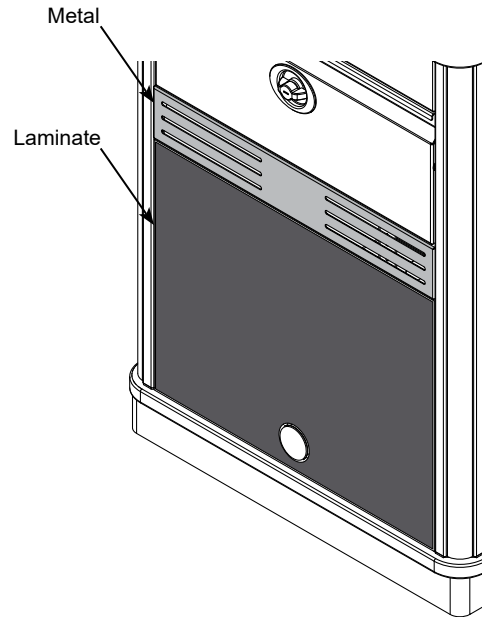

Ventilation: The narrow vented upper metal panel and grommet holes on base panel provide airflow. The laminate panel itself does not have integrated vents.

<b>ORDER CODE C =</b>	Drawer on left, w/ metal side panel
<b>ORDER CODE D =</b>	Drawer on left, w/ laminate side panel

<b>ORDER CODE E =</b>	No drawer, w/ metal side panel
<b>ORDER CODE F =</b>	No drawer, w/ laminate side panel

<b>ORDER CODE A =</b>	Drawer on right, w/ metal side panel
<b>ORDER CODE B =</b>	Drawer on right, w/ laminate side panel

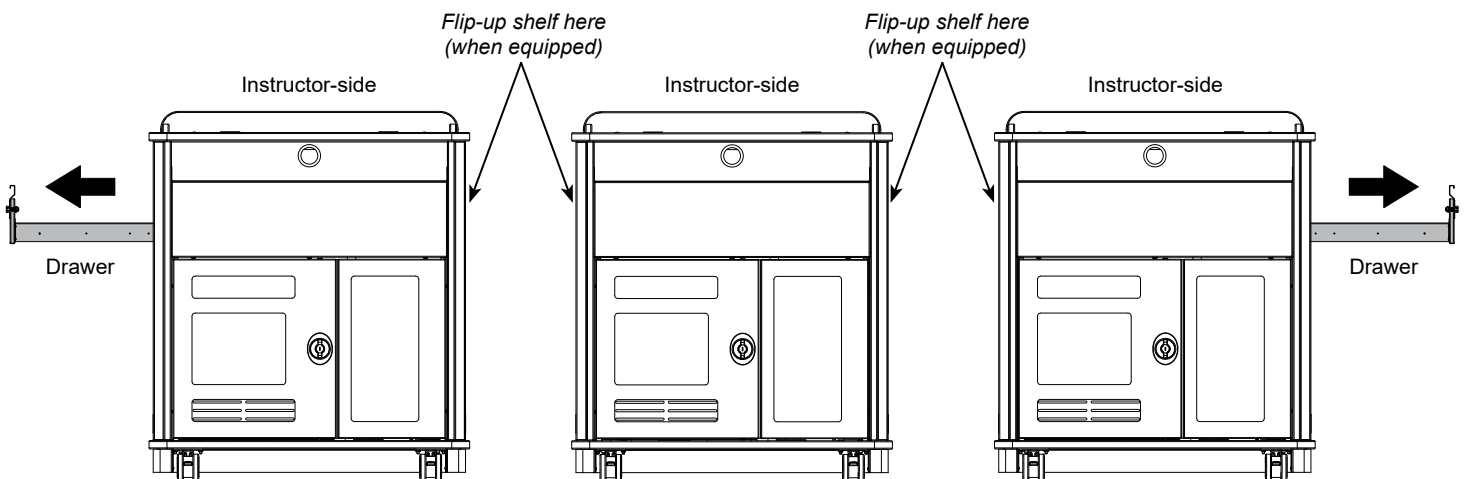

2 flip-up shelves can be installed in this configuration (one on each side)



**ORDER CODE 0 =** None

**ORDER CODE 1 =** 12RU Slide-in rack cube

**12RU Rack Cube**

- One rack cube can be installed behind the primary door on the Media Manager Elite Lectern
- Polyethylene slides on bottom for easy removal
- Can be secured to base panel
- Compatible with most 4.75" cooling fans
- Color: black
- Factory-installed

Rack rail: 12RU front and rear  
 19.125"W [48.58 cm] x 19.031"D [48.34 cm]  
 Dimensions: x 21.25"H [53.97 cm]  
 Compatible with most 4.75" fans with  
 Mounts for cooling fans: 4.13" mounting hole spacing (12 mounting locations available)

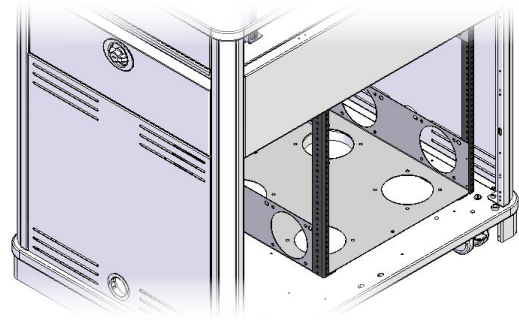

**Note:** If rack rail mounting is needed in the lower section of the lectern, the rack cube must be specified. The lectern does not provide any rack-mount capabilities without the cube.

**ORDER CODE 2 =** Keyboard Tray

**ORDER CODE 3 =** 2RU Rack Rail

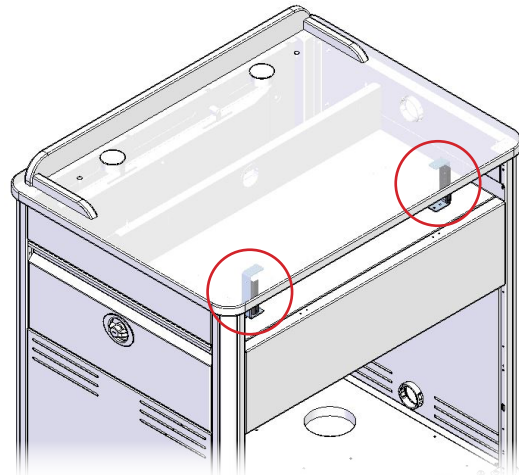
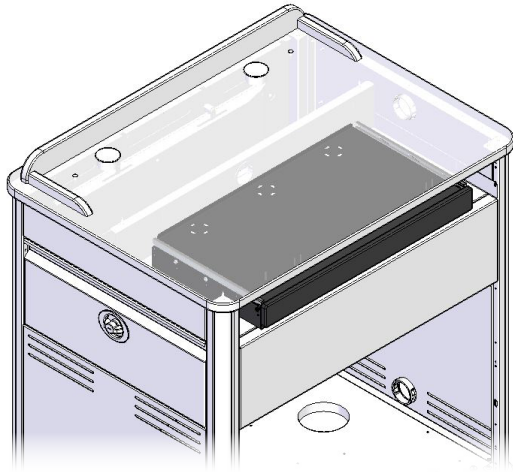

**ORDER CODE 4 =** Keyboard Tray, and 12RU Rack Cube

**ORDER CODE 5 =** 2RU Rack Rail, and 12RU Rack Cube

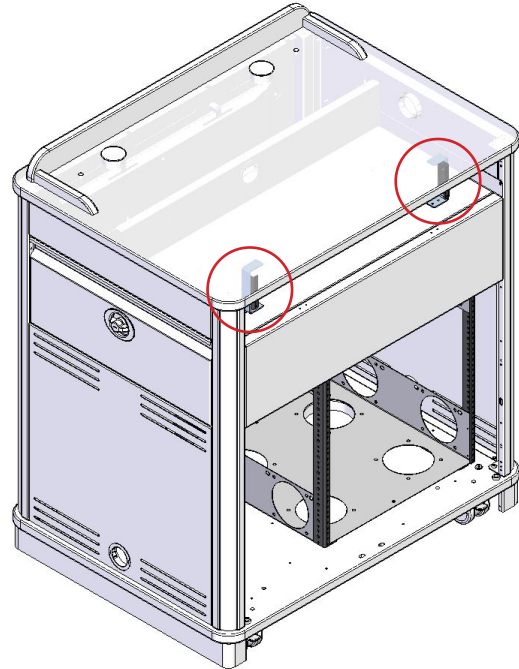
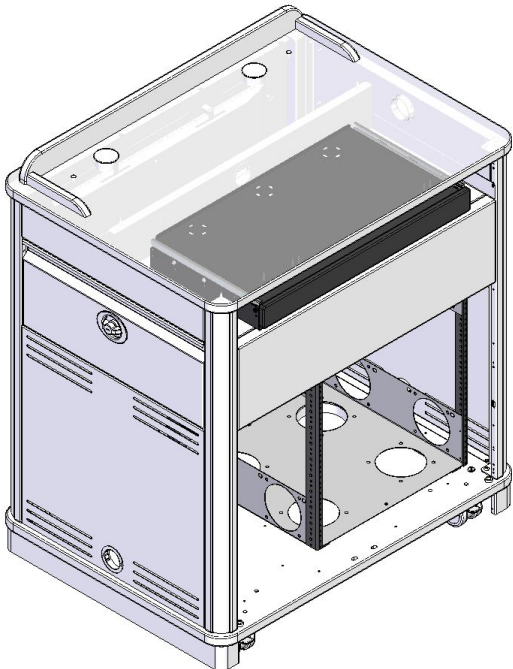



Base

ORDER CODE 00 = None

ORDER CODE TK = Toekick Kit

- Attaches to floor and lectern when mobility is not necessary or desired (floor fasteners not included)
- Conceals wheels
- Includes access panel
- Customer-installed

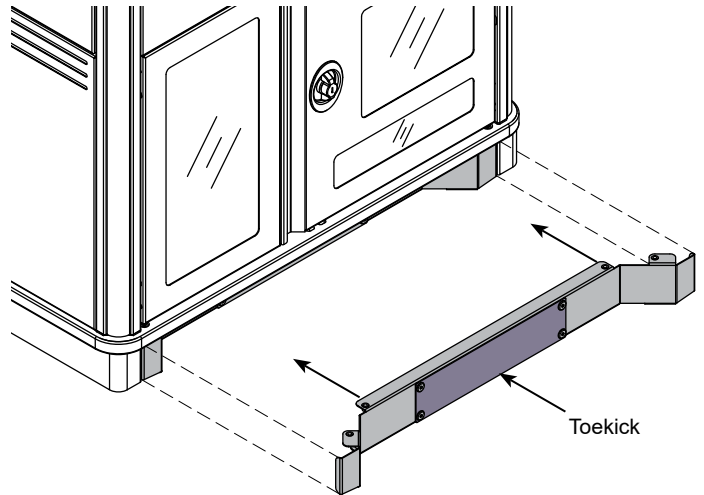

Customized Logo Panel

Customized Metal Logo Panel

ORDER CODE 0 =	None
ORDER CODE 1 =	Custom logo with <u>matching laminate</u> backer
ORDER CODE 3 =	Custom logo with <u>black laminate</u> backer
ORDER CODE 4 =	Custom logo with <u>white laminate</u> backer
ORDER CODE 5 =	Custom logo with printed backer

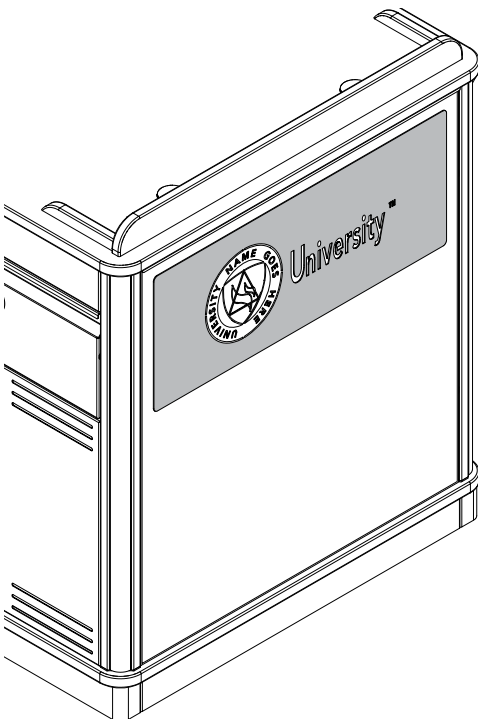

Customized Acrylic Logo Panel

ORDER CODE 6 = Acrylic logo panel

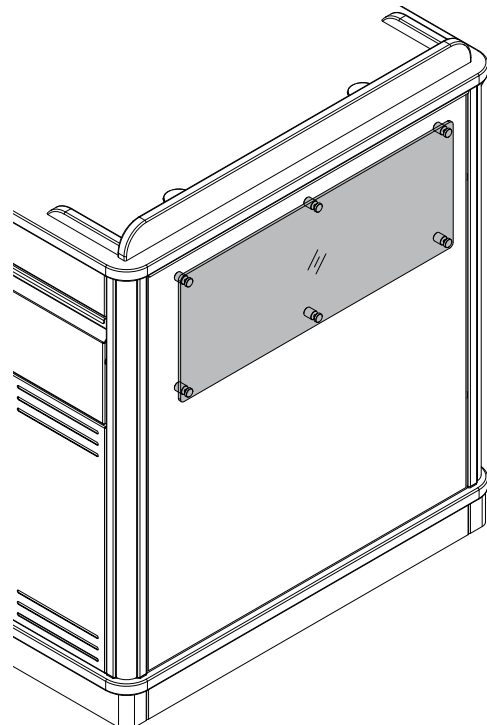

Media Manager Elite Lectern with surround

(Shown with drawer on left)

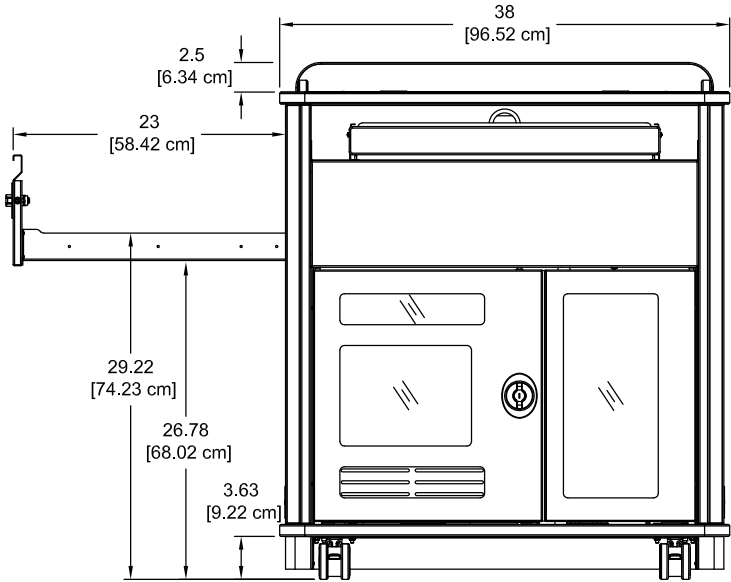
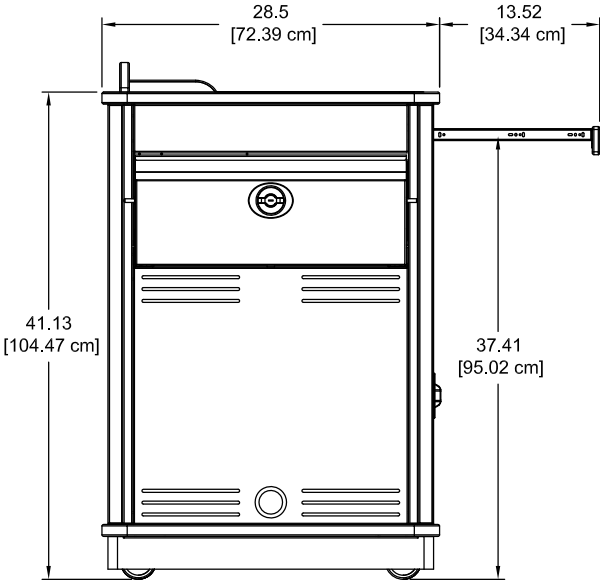
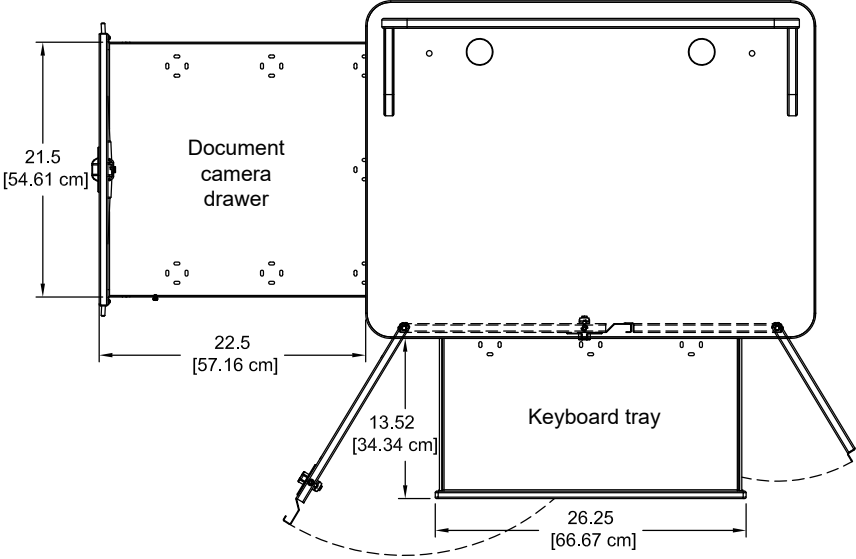
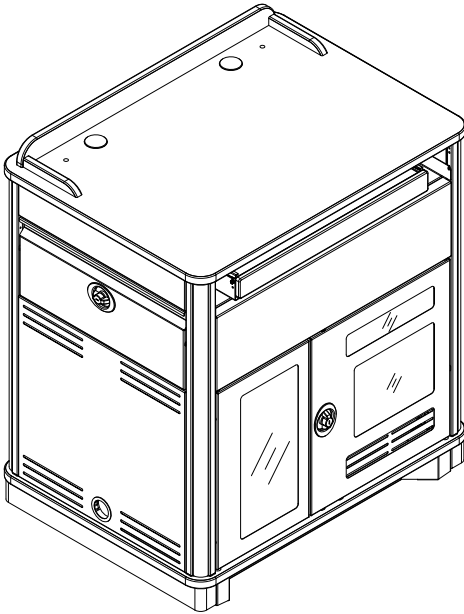

Media Manager Elite Lectern with Overbridge

(Shown with drawer on right, rack cube and flip-up shelf on left, and doors removed)

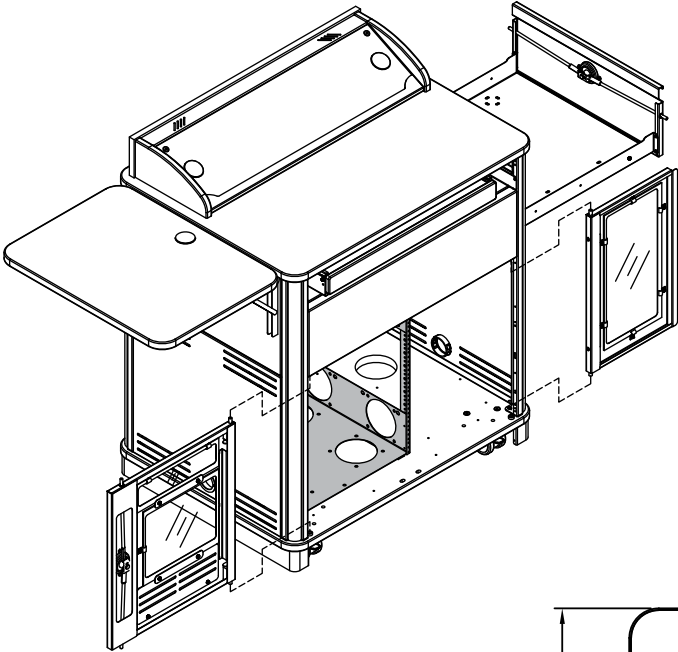

Flip-up shelf

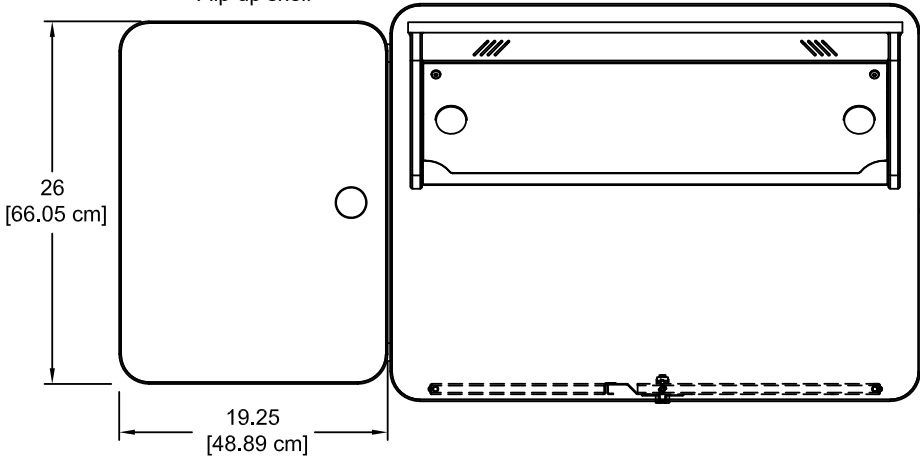

Note: Modified worksurface or overbridge insert panel cutouts should be reviewed by Spectrum to ensure clearance of brackets, keyboard slides, or other objects under the worksurface.

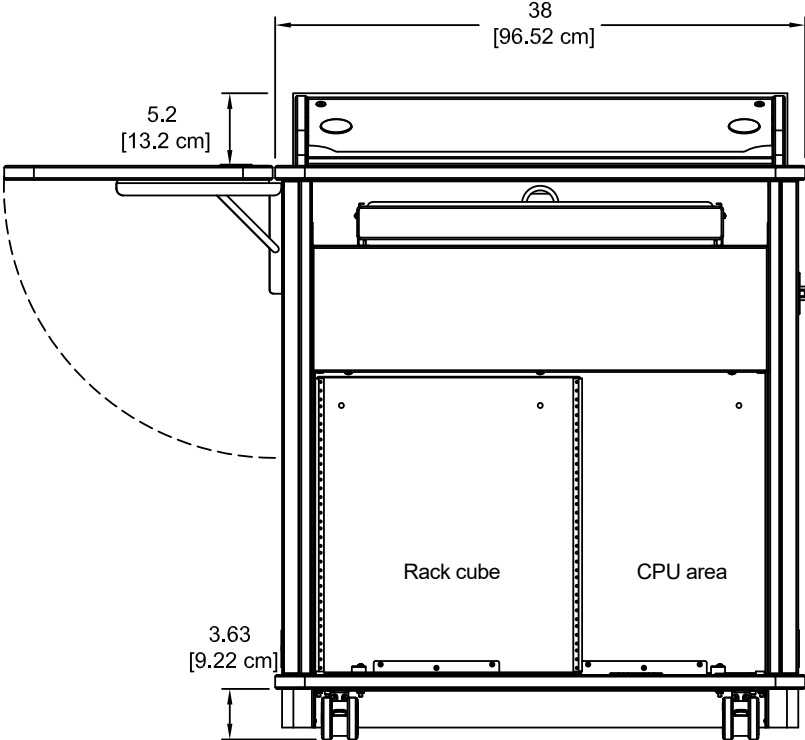
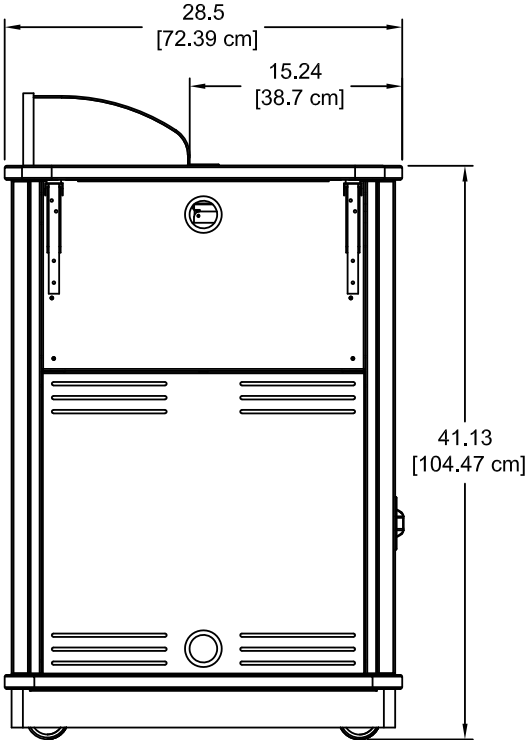

Media Manager Elite Lectern overbridge insert panel blank  
(flat view)

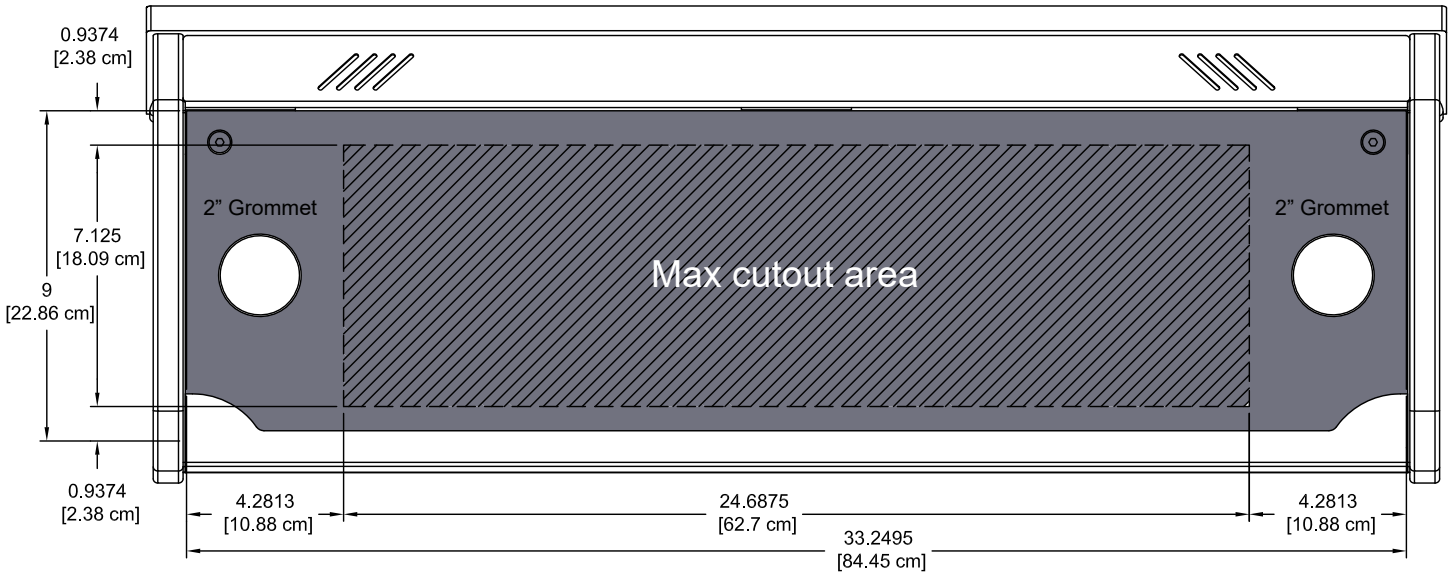

Overbridge Section View

Note: The Overbridge Control Console™ has been designed for many of the currently available controllers on the market, however, modified cutouts should be reviewed by Spectrum to ensure clearance of brackets, keyboard slides, or other objects under the worksurface.

**Contact Spectrum to specify cutout size(s) and location(s).**

Cutouts can be made in the blank insert panel by the customer after the lectern has been purchased, but are only recommended within the cutout area shown.

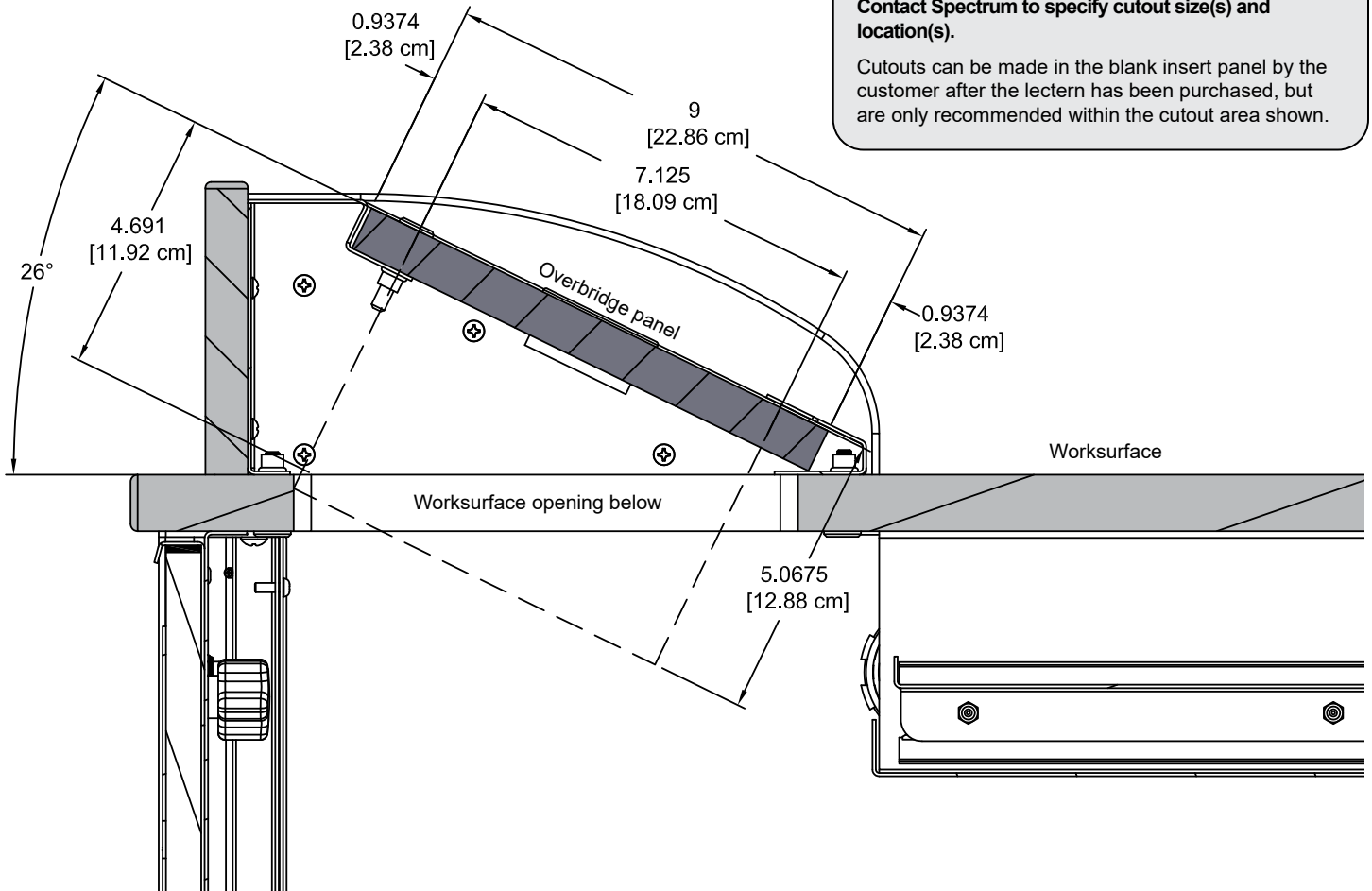

Optional 12RU Rack Cube

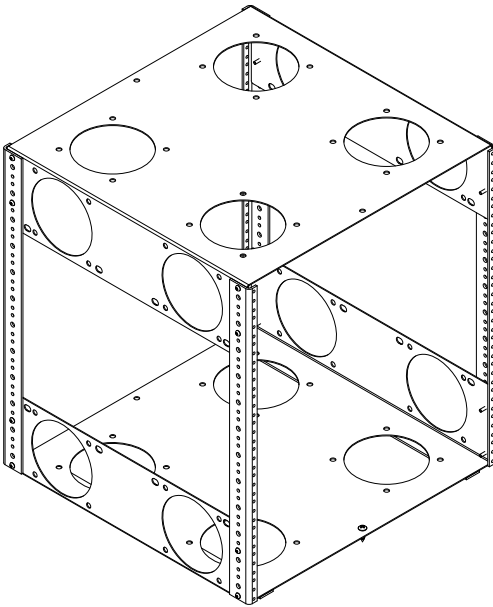

Maximum component depth available

18.781  
[47.7 cm]

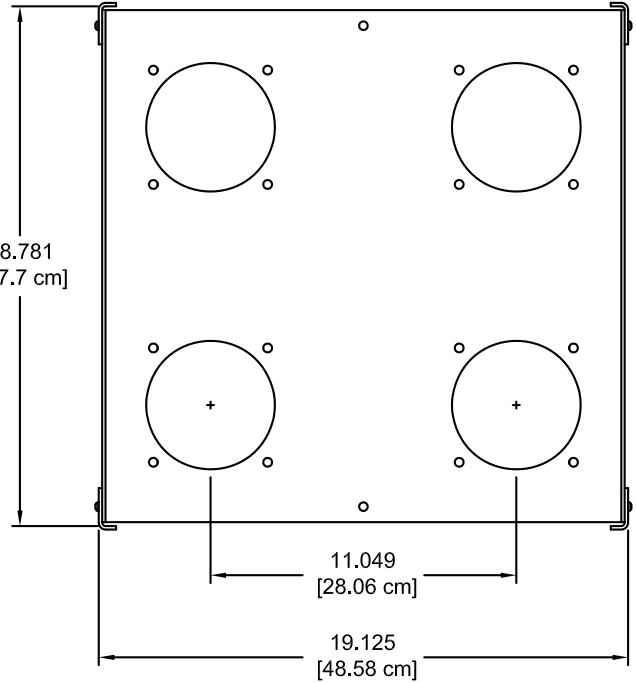

Note: Check the dimensions of all equipment before installation.

(Overall depth)

19.031  
[48.34 cm]

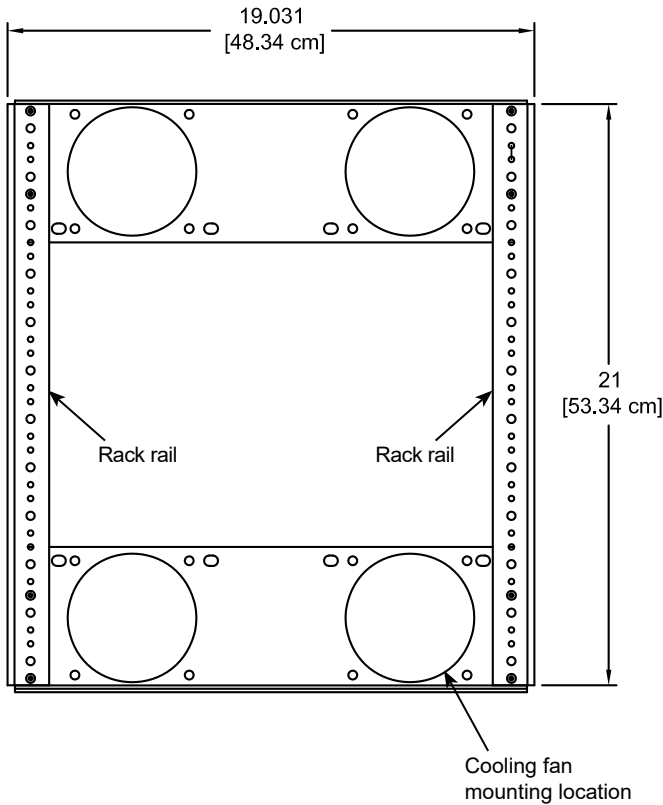

Primary instructor-side door

12.848  
[32.64 cm]

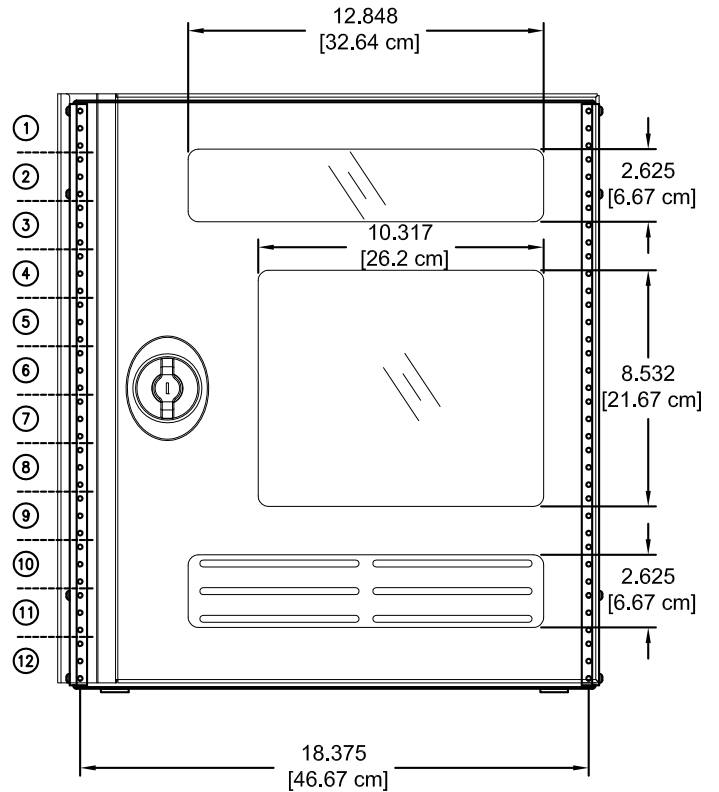

## Accessories

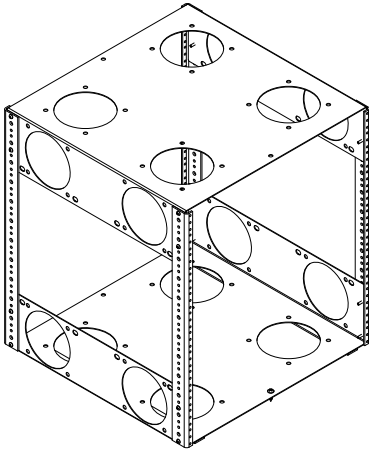

### 12RU Rack Cube - 55197

- One rack cube can be installed on the left or right side of the Media Manager Elite Lectern
- Polyethylene slides on bottom for easy removal
- Can be secured to base panel on the left or right side of the Media Manager Elite Lectern
- Cooling fan compatible
- Color: black
- Customer-installed

Rack rail:	12RU front and rear
Dimensions:	19.125"W [48.58 cm] x 19.031"D [48.34 cm] x 21.25"H [53.97 cm]
Mounts for cooling fans:	Compatible with most 4.7" fans with 4.13" mounting hole spacing (12 mounting locations available)
Unit weight:	21 lb [9.5 kg]
Shipping weight:	22 lb [10 kg]

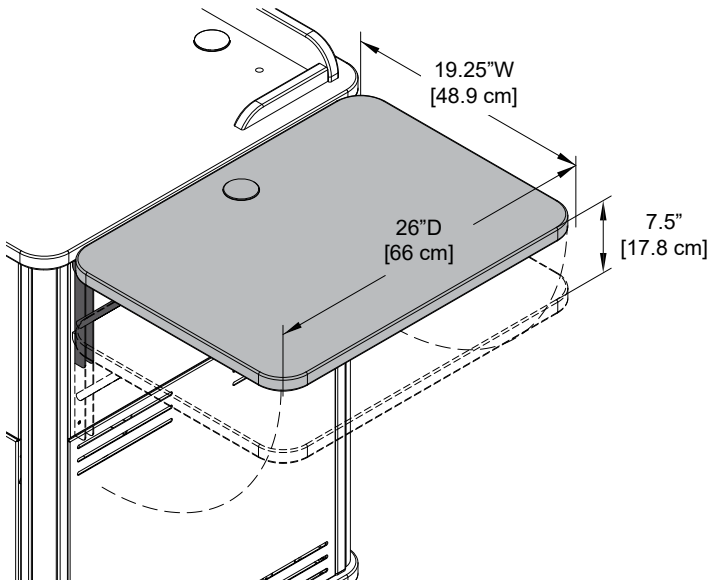

### Flip-Up Shelf - 55269

- Shelf hinges lock into place in the upright position
- Includes 2" grommet
- Available in White Chalk Dry Erase laminate
- Two height positions available

Weight capacity:	35 lb [15.9 kg]
Dimensions:	19.25"W [48.9 cm] x 26"D [66 cm] x 1"H [2.54 cm]
Height positions available:	41"H [104.1 cm] (level with worksurface) 33.5"H [85.1 cm]
Shipping weight:	21 lb (9.5 kg)

Note: Power and communication wiring for document cameras, laptop computers, and/or projectors placed on the flip-up shelf should be routed on top of the audience-side of the shelf. Use of the shelf grommet hole for wiring will result in pinching of the cords when the shelf is folded.

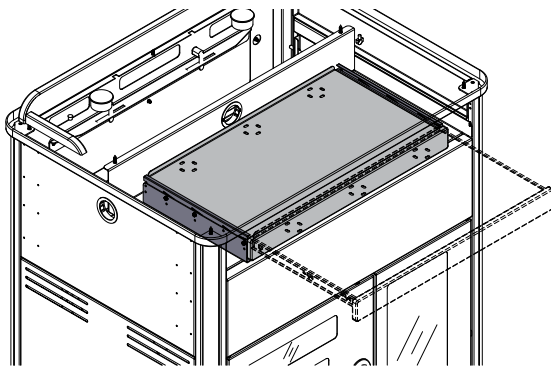

### Keyboard Tray - 95537

- Supports large keyboards with mouse
- Wiring slots
- Can be flipped and used as a storage drawer
- **Not compatible with 2RU Rack Rail Kit**

Tray dimensions:	25"W [63.5 cm] x 13.8"D [35 cm] x 3"H [7.6 cm]
Slides:	14" [35.6 cm] extension
Weight capacity:	25 lb [11.4 kg]
Shipping weight:	13 lb [5.9 kg]

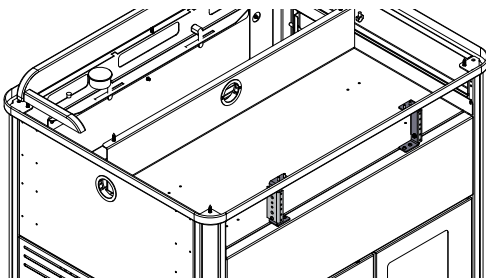

### 2RU Rack Rail Kit - 55113

- Adds an additional 2RU to lectern
- **Not compatible with keyboard tray**

Rack Units:	2RU
Shipping weight:	1 lb (.5 kg)



### Customized Metal Logo Panel - 55199

- Attaches to audience-side of lectern
- Available with black, white, or matching laminate backer
- To get panel customized-contact Spectrum for details
- New logos require a first time logo charge
- Customer-installed

Dimensions:	30"W [76.2 cm] x 12"H [30.48 cm]
Available logo area:	28"W [71.1 cm] x 10"H [25.41 cm]
Unit weight:	6 lb [2.7 kg]
Shipping weight:	8 lb [3.6 kg]

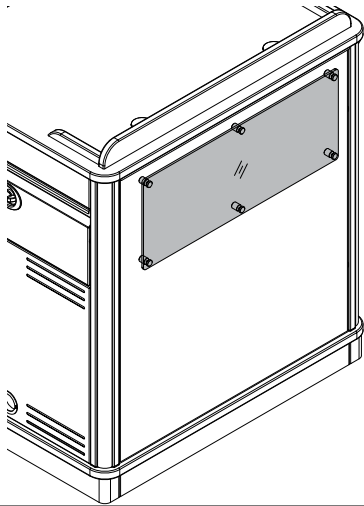

### Customized Acrylic Logo Panel - 55199

- Attaches to audience-side of lectern
- Clear acrylic mounted on standoffs
- New logos require a first time logo charge
- Customer-installed
- To get panel customized-contact Spectrum for details

Dimensions:	30"W [76.2 cm] x 12"H [30.5 cm]
Unit weight:	3.7 lb [1.7 kg]
Shipping weight:	4.7 lb [2.1 kg]

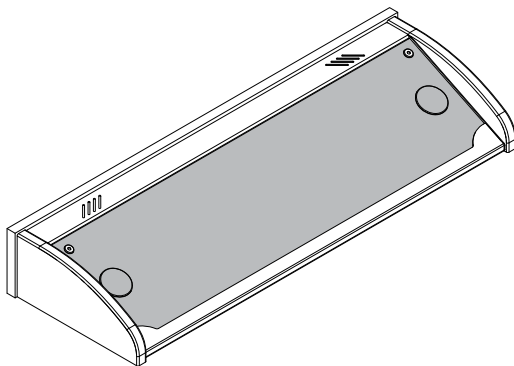

### Overbridge Insert Panel-Large - 96507

- Panel for overbridge version only (overbridge not available separately)
- Contact Spectrum to specify cutout size(s) and position(s)
- Includes two 2" [5.08 cm] grommets with covers
- Customer-installed

Dimensions:	33.25"W [84.5 cm] x 9"D [22.9 cm] x .79"H [2 cm]
Unit weight:	N/A
Shipping weight:	8.5 lb [3.9 kg]

Insert panels are available to customers needing a replacement panel or different cutouts for technology upgrades.

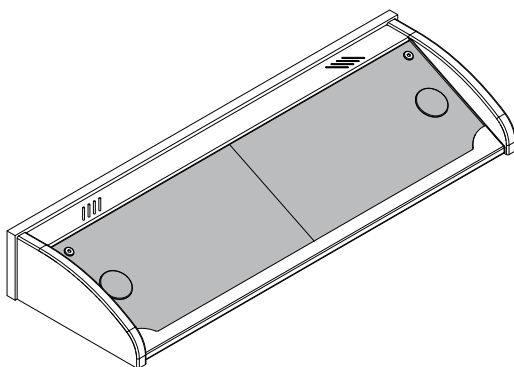

### Two-piece Overbridge Insert Panel-Large - 96513

- Split panel for overbridge version only
- Contact Spectrum to specify cutout size(s) and position(s)
- Includes 2" [5.08 cm] grommets with covers
- Customer-installed

Dimensions:	16.625"W [42.23 cm] x 9"D [22.86 cm] x .79"H [2 cm]
Unit weight:	N/A
Shipping weight:	8.5 lb [3.9 kg]



**Cooling Fan for Media Manager Series Lecterns - 99051**

- Exhausts hot air from inside lectern
- Installs inside lectern at top of rack cabinet
- Mounts to side panel vent slots with two screws
- Customer-installed

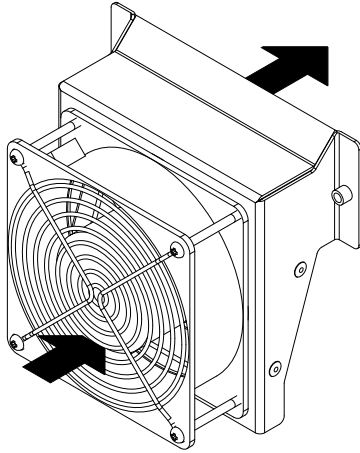

Electric Fan:	• Voltage: 115VAC (single phase)	• Noise: 28 dB
	• Power: 5.5W	• Air flow: 49.4 CFM (1.40m³/min)
	• Current: .08A	• Frame material: Aluminum
	• 1450 RPM	• Blade material: Polycarbonate, Fiberglass reinforced
	• Dimensions: 119 mm x 119 mm	
	• Ball Bearing	
Power cord:	18ga, 48" nominal length, 6A 125V~ (2 prong plug)	
Mounting bracket:	• 16-gauge steel	
	• Black powder coat	
	• Mounting screws included	
Unit weight:	2.3 lb [1.05 kg]	
Shipping weight:	3 lb [1.36 kg]	

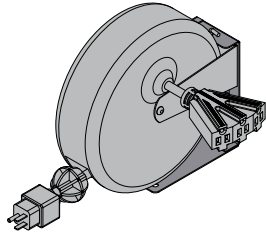

**Universal Cord Reel Kit - 99037**

- Includes universal mounting bracket
- Mounts inside lectern to base panel
- Adjustable ball stop and releasable cord-locking ratchet holds the cord at any length up to 15'
- cUL listed
- Customer-installed

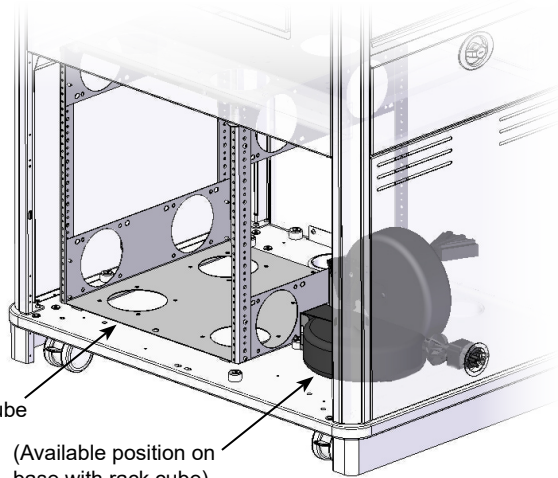

Power cord:	15' nominal, 12 AWG retractable power cord
Power receptacles:	• Molded 3-prong male plug with 15A breaker and reset button
	• Tri-tap (3-outlet) receptacle
Universal mounting bracket:	• 16-gauge steel
	• Black powder coat
	• Includes mounting screws
Unit weight:	10 lb [4.5 kg]
Shipping weight:	10.8 lb [4.9 kg]

The cord reel is intended to provide temporary access to electrical outlets for Spectrum mobile lecterns. Check local electrical codes prior to installation.

**Toe Kick Kit - 55198**

- Attaches to floor and lectern when mobility is not necessary or desired (floor fasteners not included)
- Conceals casters
- Includes access panel
- Customer-installed
- Shipping weight: 12 lb [5.4 kg]

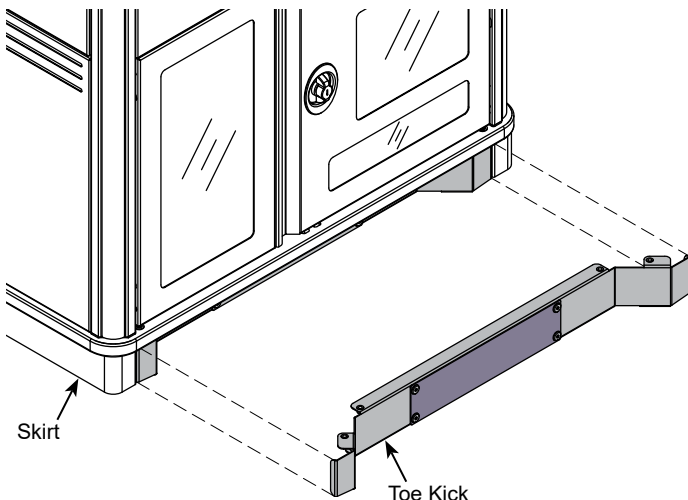

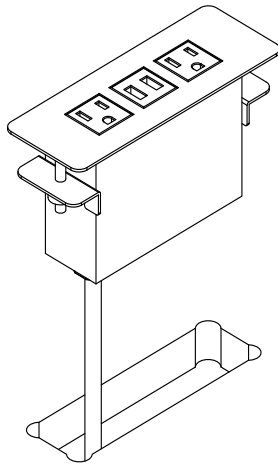

**USB-C Power Module - 99075**

- (2) AC power outlets (tamper-resistant)
- (1) USB charge port
- (1) USB-C charge port
- Aluminum housing and flange
- Thumbscrew clamps
- ETL-certified
- Available in black, silver, or white
- Customer-installed

Cutout required:	5.65"W x 1.65"D cutout exists under flip-up lid
Power cord:	10' [305 cm] 14AWG *3C power cord
Power receptacles:	125V, 60hz, 15A tamper-resistant
USB-C charging port:	2.4A (12W) (non data compatible)
USB charging port:	2.1A (10.5W) (non data compatible)
Dimensions:	6.38"W [16.2 cm] x 2.36"D [6 cm] x 3.54"H [9 cm]
Unit weight:	2 lb [.9 kg]
Shipping weight:	2.35 lb [1 kg]



**7-Outlet Power Strip - 99024**

- Electrical Rating: AC 125V, 15 Amps
- 1000 Joules surge capacity
- 12' cord length
- LED switch
- UL Listed
- Shipping weight: 1.9 lb [.86 kg]

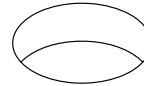
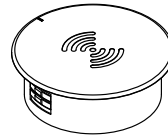

**EM Wireless Charging Pad - 99057**

- Uses electromagnetic technology to charge Qi V1.2 compliant IC devices ("Qi" enabled)
- LED to confirm pairing / charging
- Security tab prevents theft
- Requires 3" round cutout to be made by customer
- UL-certified

Note: The unit requires a 7" diameter of clearance to work with Qi-enabled phones placed in any orientation. The 3" dia cutout should be located on the worksurface at least 3.5" from any edge.

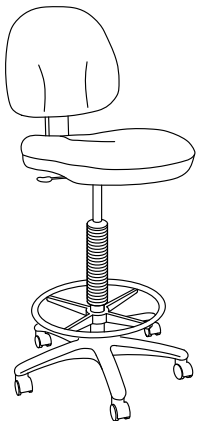

**Adjustable Drafting Stool - 38202**

- 40-52" height-adjustment via pneumatic cylinder
- 360° swivel
- Tilting backrest
- 18" diameter fixed foot ring
- 5-star base

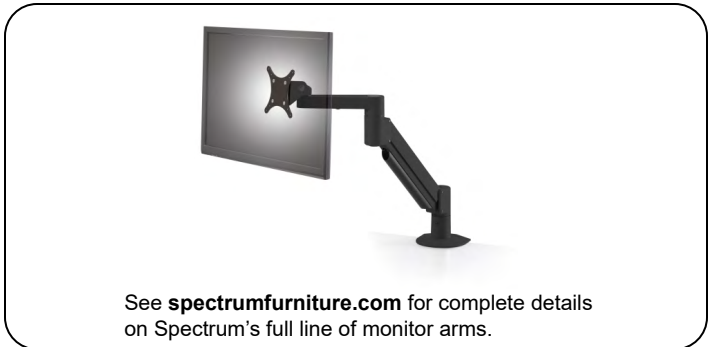

See [spectrumfurniture.com](http://spectrumfurniture.com) for complete details on Spectrum's full line of monitor arms.

# Rack-mount Accessories

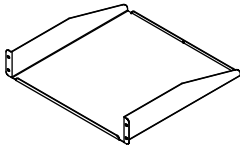

## Cantilever Shelf - 2RU - 97504

- 16ga steel
- Shelf: 17.5"W [44.45 cm] x 18"D [45.7 cm] x 3.5"H [8.89 cm]
- Weight capacity: 50 lb [22.7 kg]
- Shipping weight: 8.1 lb [3.7 kg]

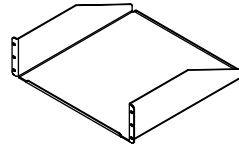

## Cantilever Shelf - 3RU - 97502

- 16ga steel
- Shelf: 17.5"W [44.45 cm] x 18"D [45.7 cm] x 5.25"H [13.33 cm]
- Weight capacity: 80 lb [36.3 kg]
- Shipping weight: 9.2 lb [4.2 kg]

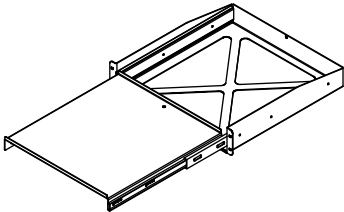

## Pull-Out Shelf - 2RU - 97505

- 16ga steel
- 17.09"W [43.42 cm] x 18.12"D [46.03 cm] x 3.5"H [8.89 cm]
- Weight capacity: 50 lb [22.7 kg]
- Shipping weight: 15.6 lb [7.1 kg]

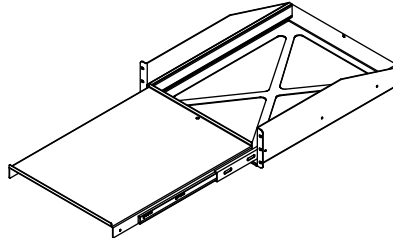

## Pull-Out Shelf - 3RU - 97503

- 16ga steel
- 17.09"W [43.42 cm] x 22.11"D [56.14 cm] x 5.25"H [13.33 cm]
- Weight capacity: 80 lb [36.3 kg]
- Shipping weight: 18.5 lb [8.4 kg]

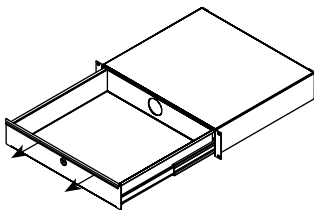

## Locking Drawer - 2RU - 97527

- 16ga steel
- Drawer: 15.97"W [40.56 cm] x 14.56"D [36.98 cm] x 3"H [7.63 cm]
- Weight capacity: 50 lb [22.7 kg]
- Shipping weight: 15.85 lb [7.2 kg]

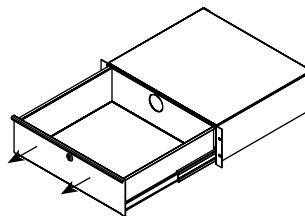

## Locking Drawer - 3RU - 97526

- 16ga steel
- Drawer: 15.97"W [40.56 cm] x 14.56"D [36.98 cm] x 5.25"H [13.33 cm]
- Weight capacity: 50 lb [22.7 kg]
- Shipping weight: 18.5 lb [8.4 kg]

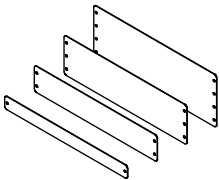

## Rack-Mount Blanks

**1RU - 97510    3RU - 97512**  
**2RU - 97511    4RU - 97513**

- Fills rack spaces where components are not needed
- 16 ga steel
- Shipping weight: <1 lb [45 kg]

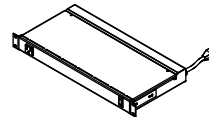

## 9-Outlet Power Strip - 1RU - 99021



- 8 outlets rear (breaker-protected)
- 1 convenience outlet front
- 115VAC, 60 Hz, 15 amps max
- 9' power cord
- Front LED power switch
- Enhanced surge protection
- ETL-listed, UL-listed
- 19"W [48.27 cm] x 9.25"D [23.5 cm] x 1.74"H [4.41 cm]
- Shipping weight: 8.7 lb [3.9 kg]

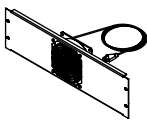

## Single Fan - 3RU - 97507

- 50 cfm
- 120V~50/60 Hz, 15/13W
- RoHS
- 19"W [48.27 cm] x 1.56"D [3.97 cm] x 5.25"H [13.33 cm]
- Shipping weight: 3.78 lb [1.7 kg]

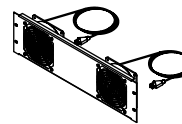

## Double Fan - 3RU - 97506

- 100 cfm
- 120V~50/60 Hz, 15/13W
- RoHS
- 19"W [48.27 cm] x 1.56"D [3.97 cm] x 5.25"H [13.33 cm]
- Shipping weight: 5.47 lb [2.5 kg]

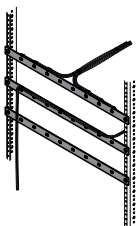

## Wire Lace Kit - 95517

- Provides wire management
- Mounts to standard rack rails
- Includes (3) lace straps and mounting screws
- Includes (12) 5.5" zip ties
- Shipping weight: 1.25 lb [.57 kg]

See [spectrumfurniture.com](http://spectrumfurniture.com) for the latest accessories and detailed warranty information.

## Warranty

### **We will make it right for you!**

Thanks for choosing Spectrum! Spectrum is committed to provide complete customer satisfaction. Each of our products is manufactured from the best materials available and each product is stringently monitored throughout the production process through our P.A.C.E. program (Product Assurance to meet Customer Expectations).

We expressly warrant that Spectrum products will be of good quality and workmanship and free from defect for the period set out in the warranty from the date of delivery.

**For a listing of all product specific warranty terms please visit our website at:**

<https://www.spectrumfurniture.com/en/resources/purchasing-terms-warranty>

**1-800-235-1262**

Toll-free HELPLINE

**[spectrum@spectrumfurniture.com](mailto:spectrum@spectrumfurniture.com)**