

Assembly Instructions

⚠ Important ⚠

Before you begin, read and comply with all safety and operating instructions, and ensure all parts and correct quantities are included.

Any parts damaged during shipment must be reported within 5 days of receipt. To report information regarding missing parts or damage, to purchase parts or accessories, or if you have any questions, please contact us.

www.spectrumfurniture.com
800-235-1262, 715-723-6750

Thank you for purchasing Spectrum products!

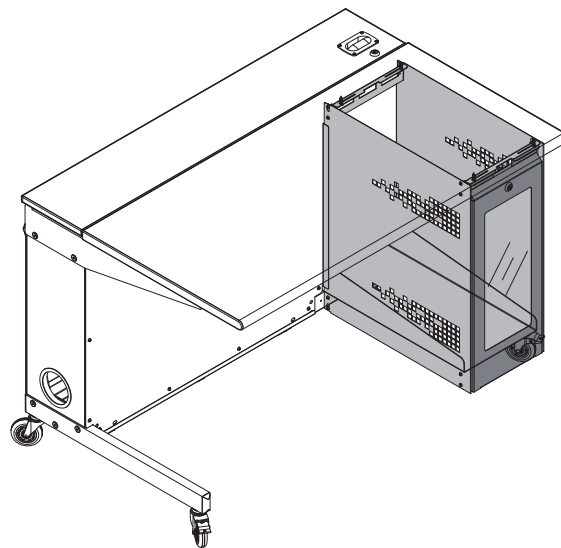

Locking CPU Enclosure for Champions Desk 95556



Assembly tip: Do not tighten component fasteners completely until all have been installed. Keeping them loose will help with alignment between parts during assembly.

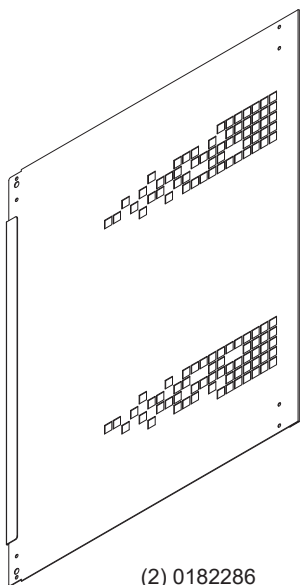

(2) 0182286
CPU side panel



(1) Access panel



(2) 0119468
Recessed
bumper

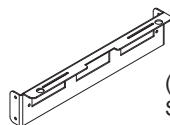

(4) 0182287
Sling bracket



(4) 0101382
#14 x 7/8"
PHSM



(18) 0100167
8-32 x 1/2"
PH Thrd ctg

1 Assemble enclosure

1. Orient the (4) sling brackets and (2) side panels as shown. (Note orientation of cutout patterns on side panels).
2. Attach the side panel to the brackets with 8-32 x 1/2" PH Thrd ctg screws. (2 screws per bracket).
3. Repeat on second side panel.
4. Install the (2) recessed bumpers as shown and secure each with (1) 8-32 x 1/2" PH thrd ctg screw.



Assembly tip: On the left side panel leave the (8) 8-32 x 1/2" PH thrd ctg screws slightly loose. This will help with assembly in step 2.

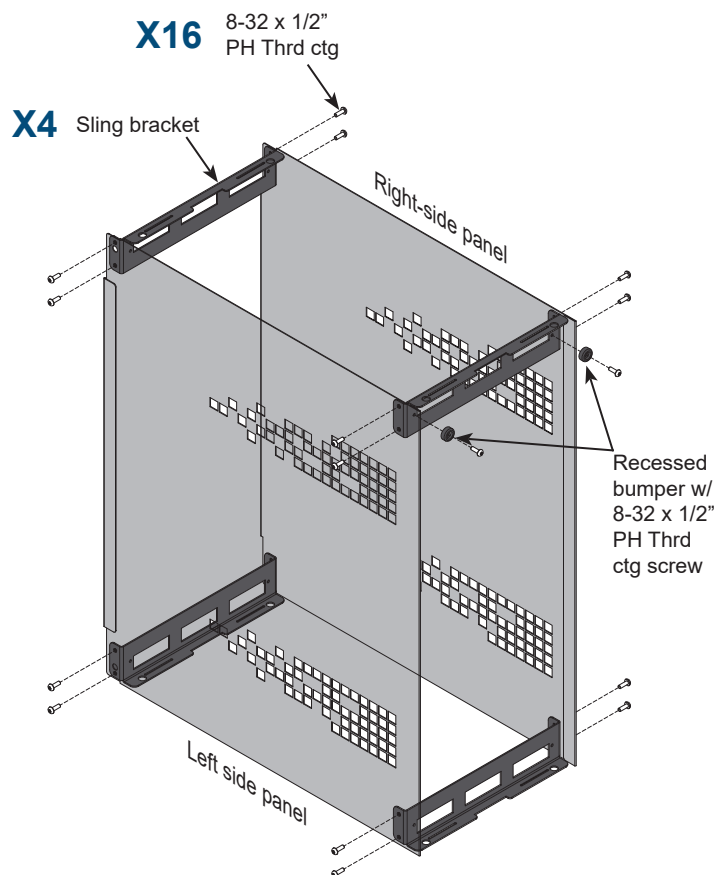

2 Attach enclosure to desk

1. Place the enclosure assembly over the existing CPU tray and align the (4) worksurface mounting holes.
2. Place a cardboard box or equivalent temporary support under the enclosure.
3. Secure to worksurface with (4) #14 x 7/8" PHSM screws.
4. Tighten the (8) 8-32 x 1/2" PH thrd ctg screws on the left side panel.

3 Install access panel

1. Set access panel tabs into lower bracket slots and tip up into place.
2. Lock to secure panel.

