

Technical Specifications

37432

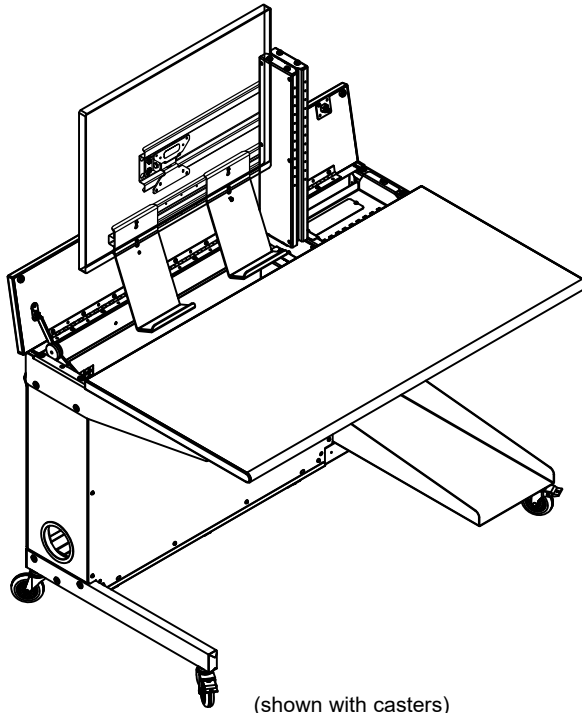

(shown with casters)

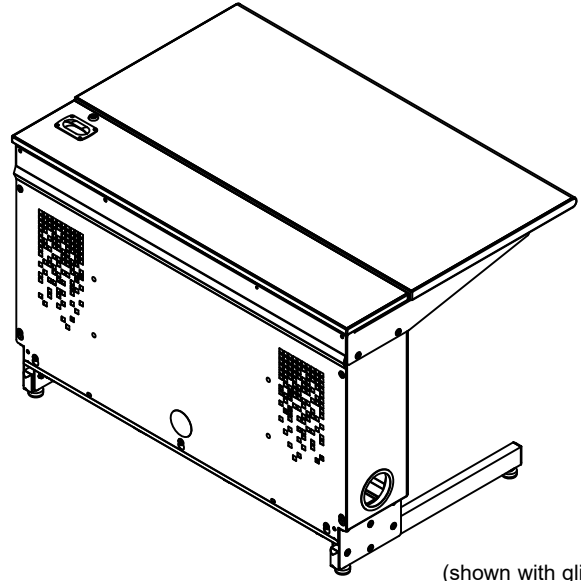

(shown with glides)

Designed with advanced features that can be dialed-in for competition. Provide the ultimate gaming experience for your esports program with the Champions Esports Desk.



Features and Benefits

- Desks provide the ability to reconfigure any classroom from a lecture room (lowered monitor, keyboard, and mouse with lid closed), into a computer lab (raised monitor, keyboard, and mouse)
- Proven, adjustment-free electric lift provides easy extension, retraction, and years of trouble-free performance
- Desk supports most monitors up to 27"
- Adjustable-height, pivoting VESA mount system for flat panel monitor provides ergonomic up/down, left/right articulation while preventing monitor damage during column movement (75mm and 100mm VESA compatible)
- 44"W x 30"D scratch and impact-resistant high-pressure laminate worksurface provides plenty of room for peripherals
- Ergonomic, bullnose front edge is easy on wrists
- Vinyl edgeband color accents match chairs and arena / team branding
- CPU tray accommodates large tower computers
- Large rectangular access cutout behind CPU tower provides direct access to connections and cables
- Wire loom protects wires and cables between CPU and monitor during column movement
- Full length flip-up lid protects and secures the flat panel monitor, keyboard, and mouse
- Friction dampener on flip-up lid provides support and dampening, and slows the lowering of the lid to keep hands and fingers safe
- Internal cutout under the flip-up lid provides the ability to mount an optional power module for easy-access to AC and USB-C power at the worksurface
- Removable audience-side panel provides security and wiring access (secured with 4mm JC bolts and hex wrench)
- Legs located at edges of desk maximize leg room
- Available with premium 3" casters (2 locking & 2 non-locking), or stationary glides
- Cables and wires are protected from student-access in an enclosed metal compartment to prevent tampering
- Large, 4" [10.2 cm] side-panel cord management grommets create a continuous cord path when desks are placed side-by-side
- Durable powder coated steel chassis provides a long-lasting finish
- Matte black finish minimizes glare and player distraction
- Optional audience-side monitor mount provides mounting for up to a 50" monitor for displaying team branding or other media
- Optional locking CPU enclosure provides security for CPU tower
- Each desk ships on its own skid. Worksurface, CPU sling, and arms/legs require customer assembly

Color Options

Desk metal and worksurface laminate is black.
Edgeband accent available in:

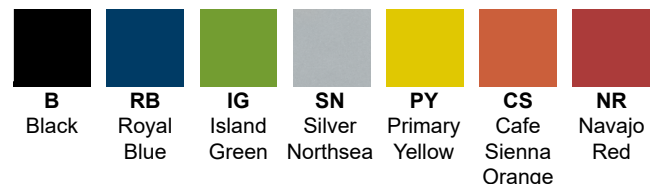

Construction

- The worksurface is constructed from 1" thick composite board with .030" high-pressure laminate on one face, and a balancing phenolic backer on the opposing face
- Edges are finished with 3mm vinyl edgeband
- All metal components are finished with a scratch-resistant powder coat epoxy
- Worksurface support arms are 12-gauge steel
- CPU shelf is 16-gauge steel
- Cord channel is 16-gauge steel
- Bottom leg rail includes weld-nuts for attaching glides or wheels
- Each desk is "knocked-down" and ships on its own skid. Worksurface, CPU sling, and arms/legs are attached by customer

Specifications

Dimensions	44"W [111.8 cm] x 30"D [76.2 cm] x 29.1"H [73.81 cm]
Maximum monitor size	Accommodates most monitors up to 27" diag Monitor width cannot exceed 24"W [62.11 cm]
CPU tower tray	Max CPU tower size: 9.692"W [24.62 cm] x 23.29"D [59.16 cm] x 20.232"H [51.4 cm] Max CPU tower weight: 70 lb [31.8 kg]
Cord channel	2.3"D [5.77 cm] x 1.9"H [4.78 cm]
Premium swivel casters (2 locking, 2 non-locking)	<ul style="list-style-type: none"> • Diameter: 3" [7.62 cm] • Weight capacity: 120 lb [54.5 kg] each
ADA-compliance*	 <ul style="list-style-type: none"> • 1 ADA seat per table <p><small>*Minimum ADA guidelines for knee clearances are 30"W x 19"D x 27"H</small></p>
Certifications / Compliance	<ul style="list-style-type: none"> • SCS Indoor Advantage Certified • Meets or exceeds applicable ANSI-BIFMA test standards
Unit weight (nominal)	145 lb [65.8 kg]
Shipping weight (nominal)	165 lb [74.9 kg]

Specifications subject to change without notice

3" casters

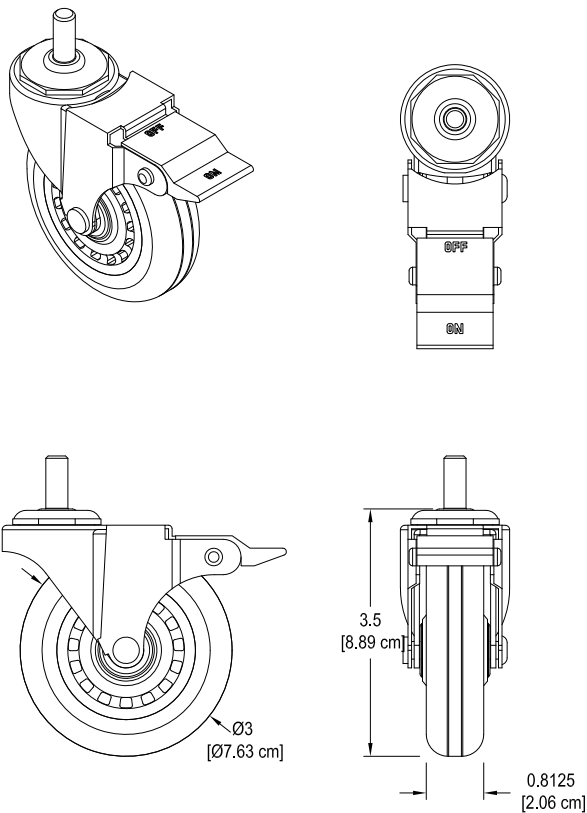

Worksurface edge

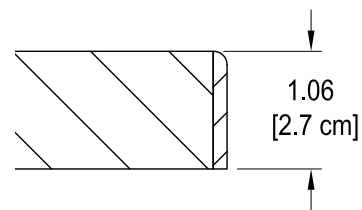

Swivel monitor mount

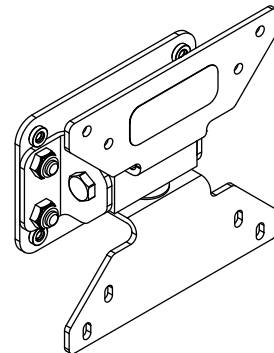

Standard Swivel VESA Monitor Mount

- Internal travel stops-provides 4-direction tilt
4° left, 4° right, 16° up, and 6° down
- Works with 75mm and 100mm VESA mounts

Note: Specific monitor size, shape, and mounting location will determine exact angles of tilt.

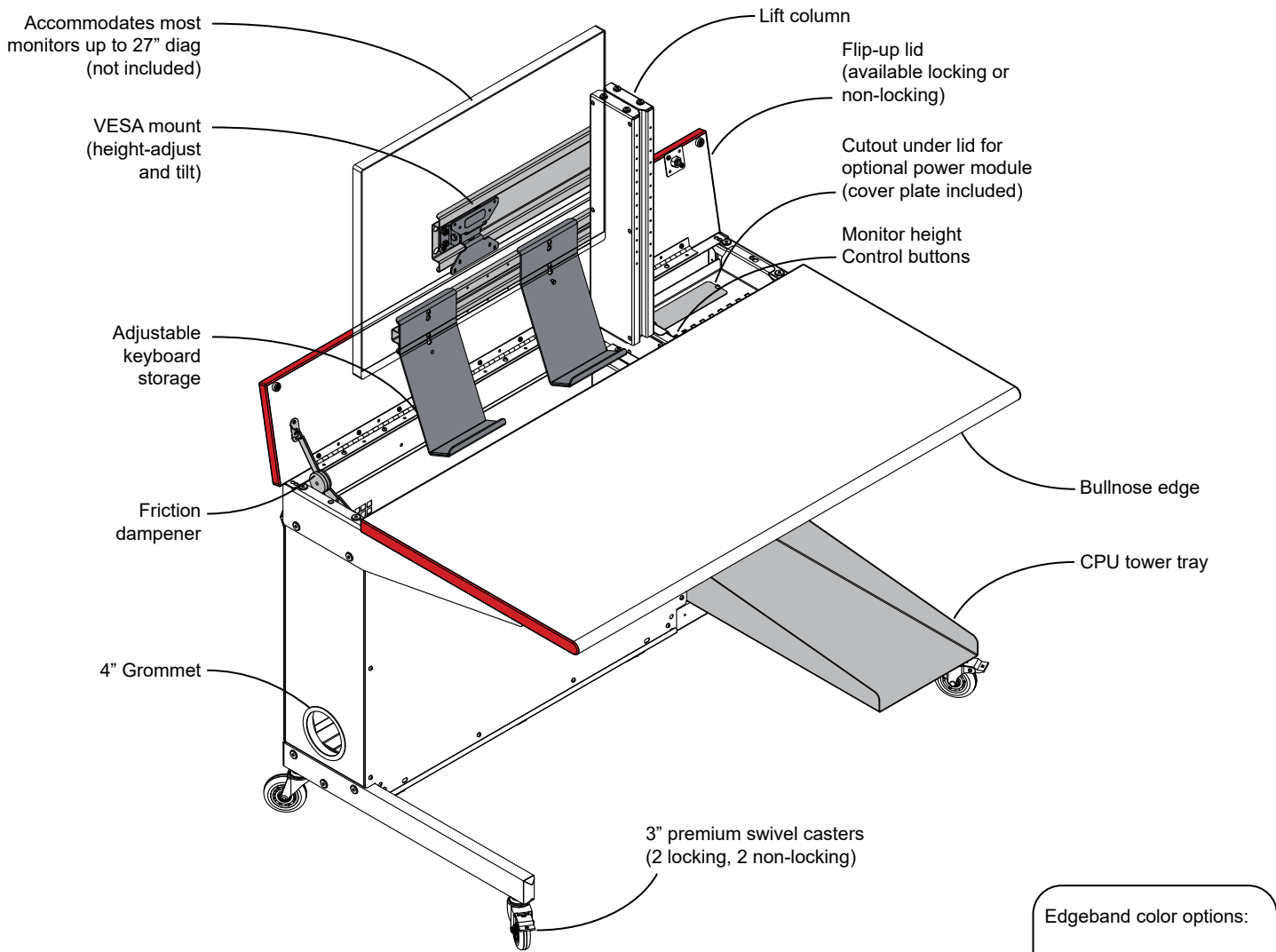

- Edgeband color options:
- B** - Black
 - RB** - Royal Blue
 - IG** - Island Green
 - SN** - Silver Northsea
 - PY** - Primary Yellow
 - CS** - Cafe Sienna Orange
 - NR** - Navajo Red

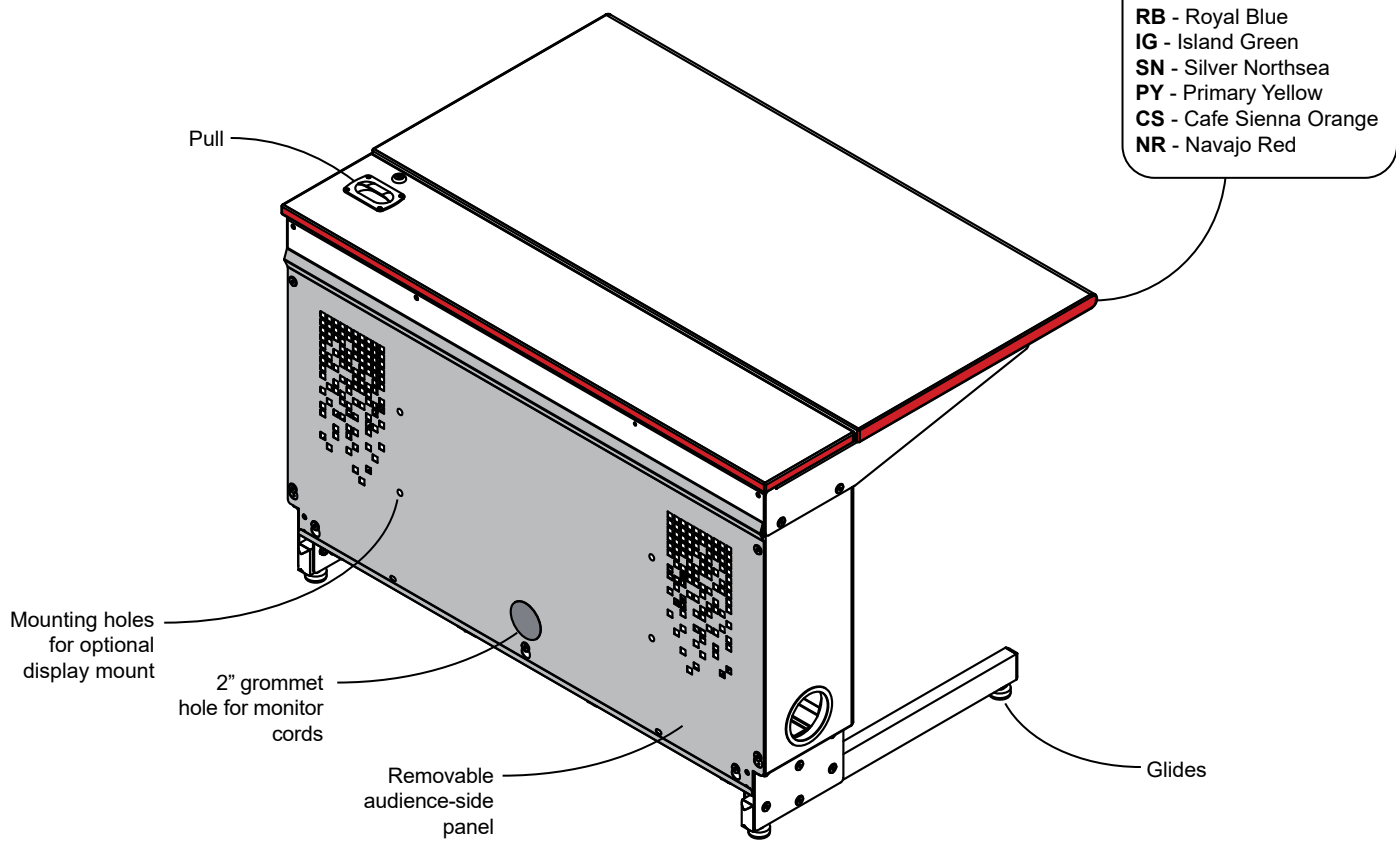

ORDER CODE 1 = Glides

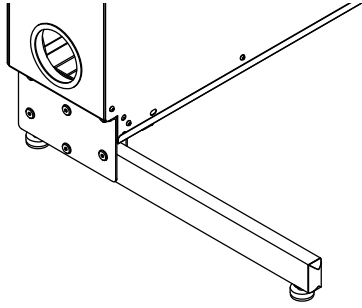

ORDER CODE 2 = Casters

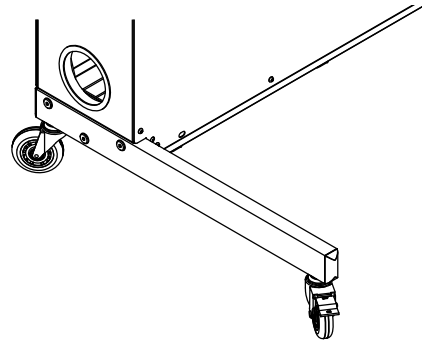

Locking Monitor Compartment

ORDER CODE 1 = None

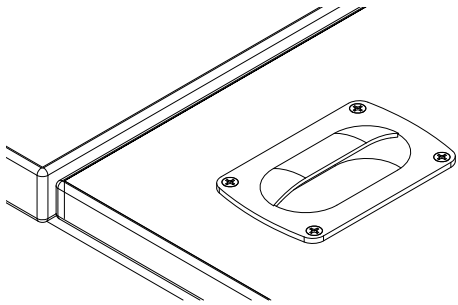

ORDER CODE 2 = Yes

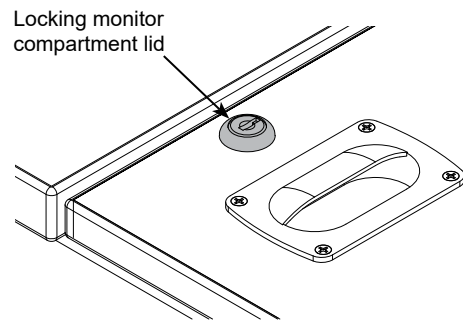

Note: When specified, one lock with (2) keys are included.

Champions Esports Desk
 (shown with casters and extended monitor)

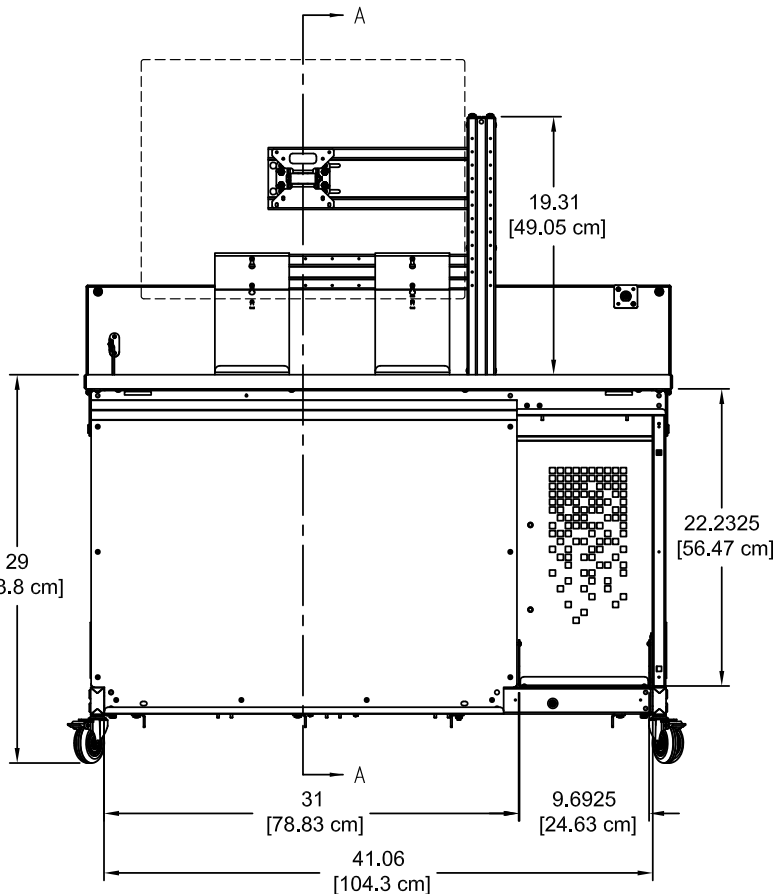
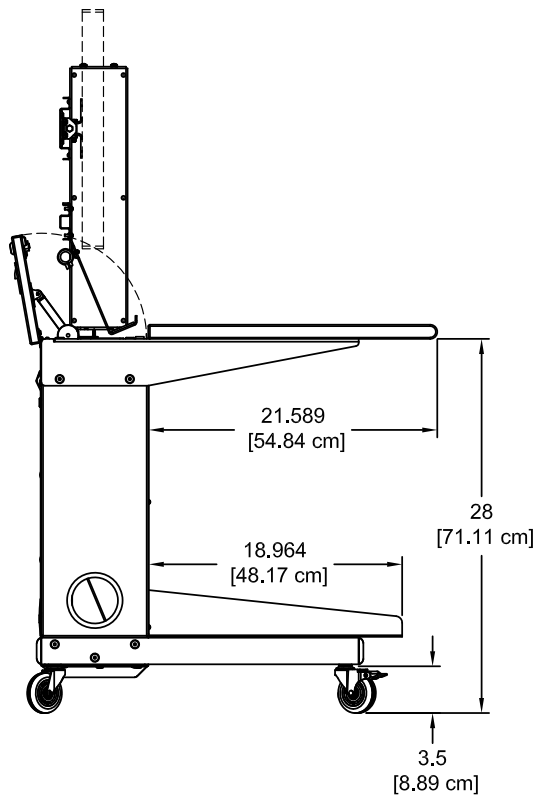
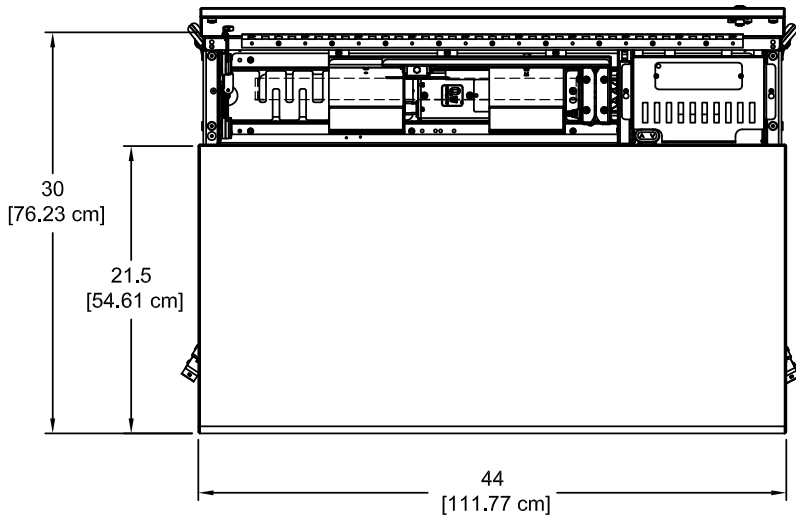
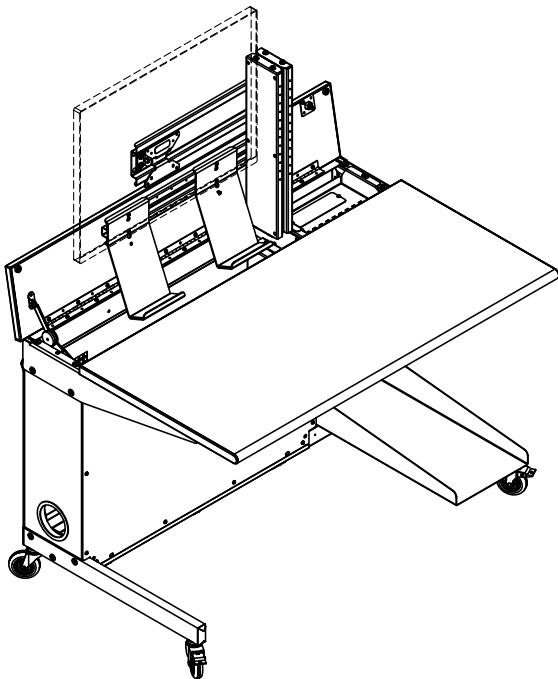

Champions Esports Desk
 (shown with glides and retracted monitor)

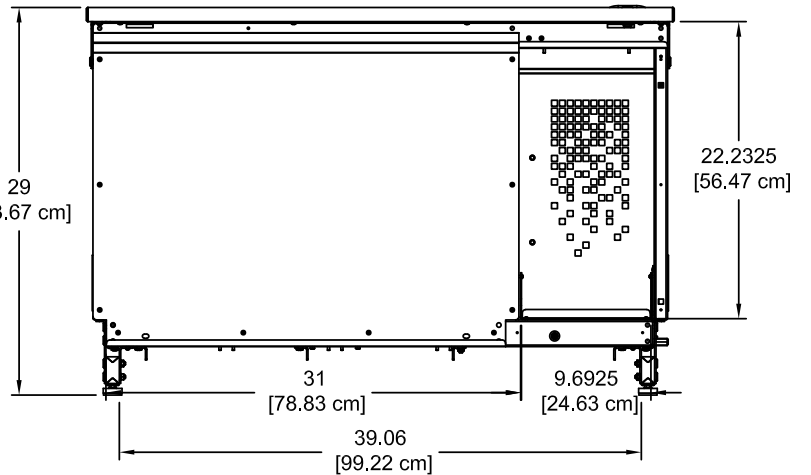
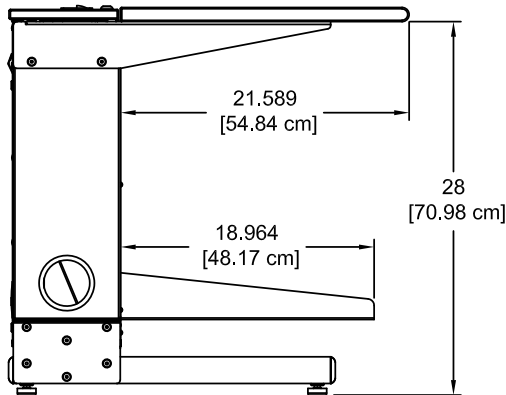
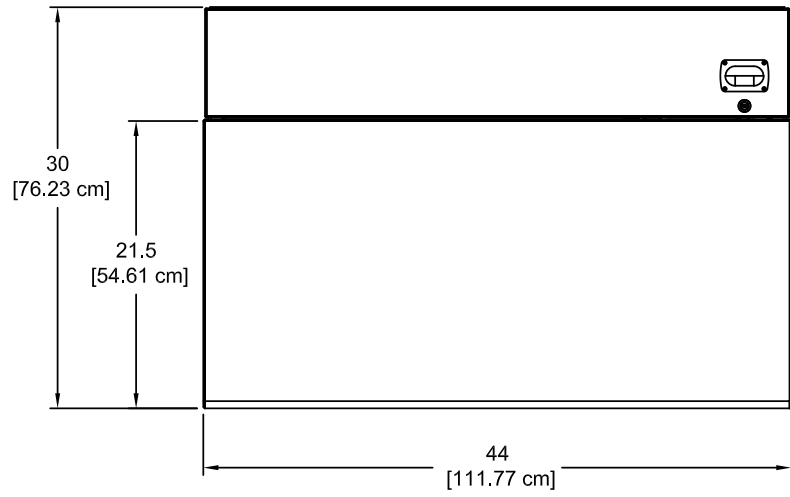
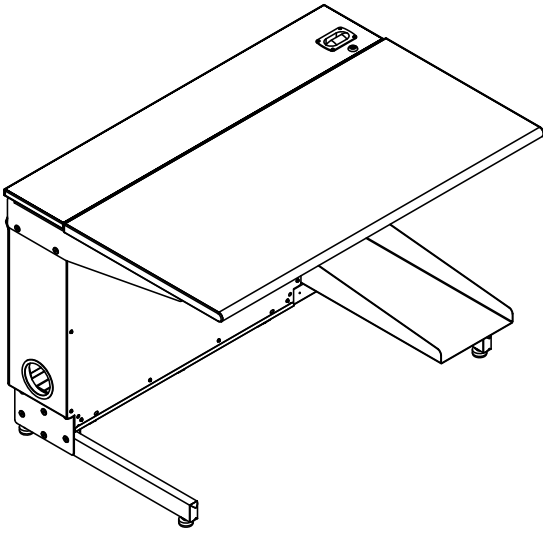

Section A-A

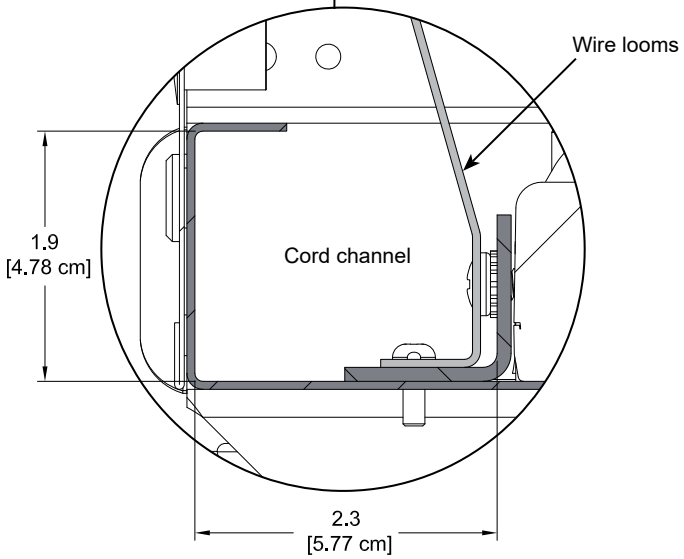
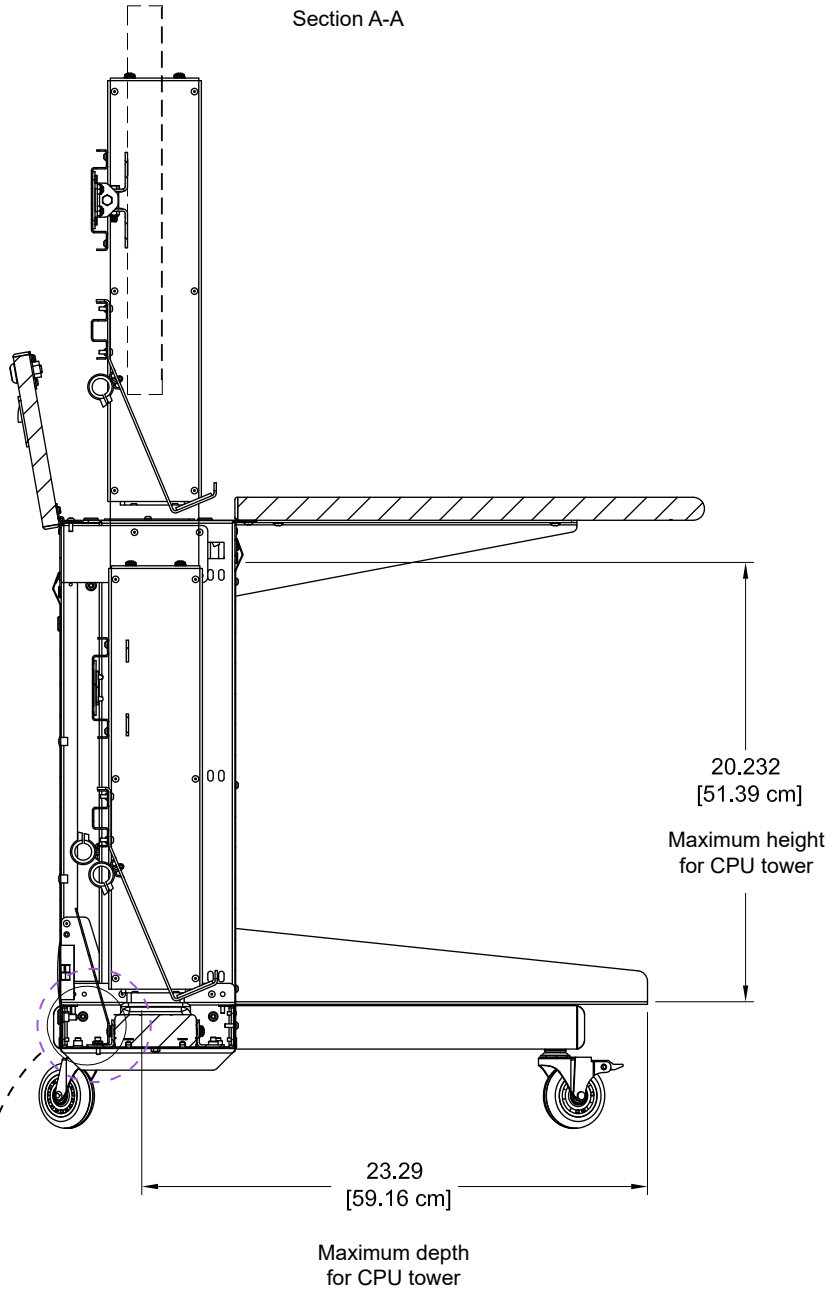

Wiring tray cutouts
(for floor box power)

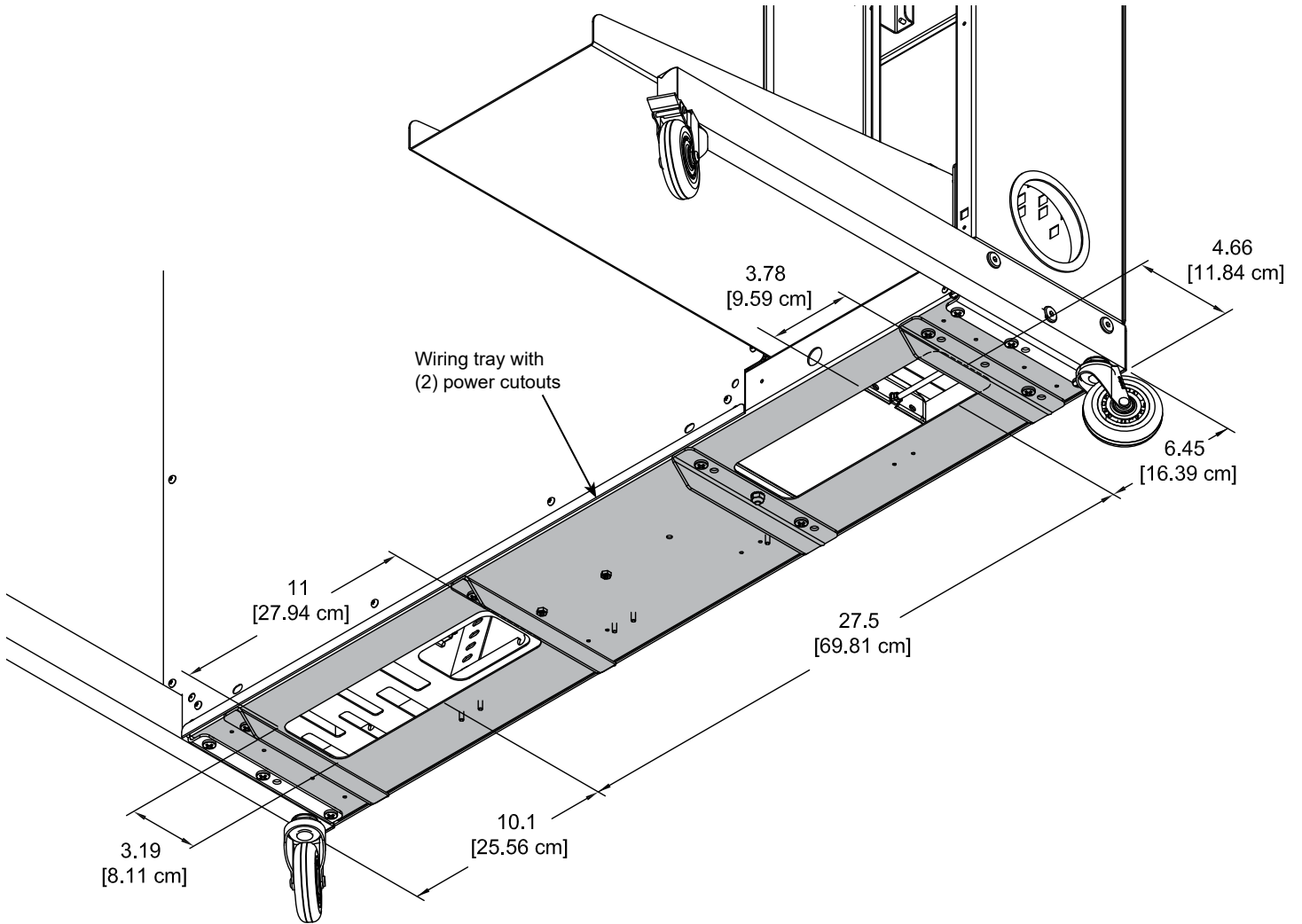

Note: The wiring tray loom panel can be removed from the left side cutout if more room is needed for electrical box connections.

Accessories

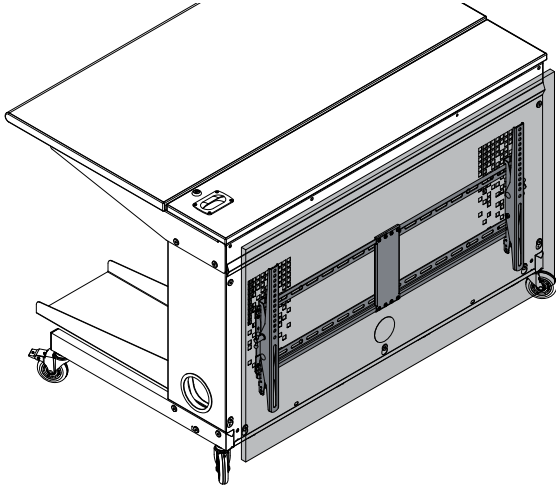

Audience-side display mount - 95557

- Provides display monitor mounting on audience-side
- Adjustable VESA-compatible
- Accommodates most monitors up to 50" diag (not included)
- Customer-installed
- Unit weight: 8 lb [3.6 kg]
- Shipping weight: 9 lb [4.1 kg]

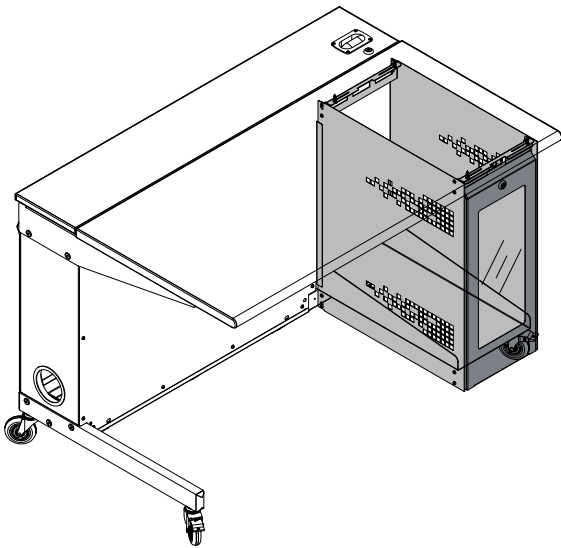

Locking CPU enclosure - 95556

- Dimensions: 10"W [25.4 cm] x 19.88"D [50.5 cm] x 24.25"H [61.6 cm]
- Black powder coat
- Locking acrylic front panel
- Ventilated side panels
- Customer-installed
- Unit weight: 14 lb [6.4 kg]
- Shipping weight: 16 lb [7.3 kg]

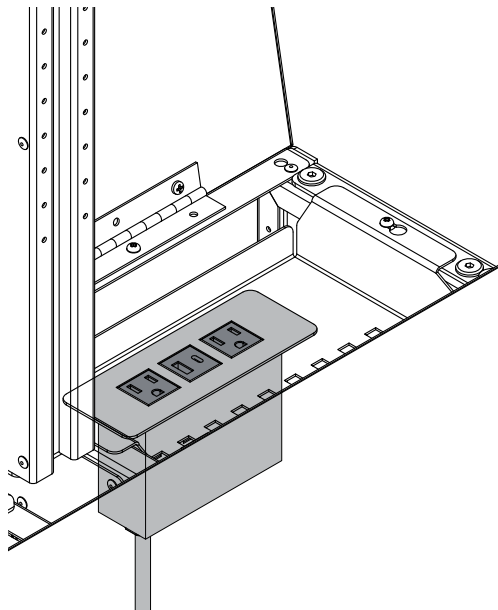

USB-C Power Module - 99075

- Mounts under flip-up lid for easy access
- (2) AC power outlets (tamper-resistant)
- (1) USB charge port
- (1) USB-C charge port
- Aluminum housing and flange
- Thumbscrew clamps
- ETL-certified
- Available in black, silver, or white
- Customer-installed

Cutout required:	5.65"W x 1.65"D cutout exists under flip-up lid
Power cord:	10' [305 cm] 14AWG *3C power cord
Power receptacles:	125V, 60hz, 15A tamper-resistant
USB-C charging port:	2.4A (12W) (non data compatible)
USB charging port:	2.1A (10.5W) (non data compatible)
Dimensions:	6.38"W [16.2 cm] x 2.36"D [6 cm] x 3.54"H [9 cm]
Unit weight:	2 lb [.9 kg]
Shipping weight:	2.35 lb [1 kg]





Esports Genova Gaming Chair

38151
38320

- Rugged carbon PVC seat stands up to hours of use
- Optimize ergonomics with the height adjustable seat
- Durable, 2D high-grade plastic arm rests can be adjusted quickly, in both height and rotation
- Fully reclining, 180° tilt mechanism allows you to lay back to stretch or rest up for the next game
- Back and neck pillows are adjustable to provide superior support for extended tournament play
- Available in multiple colors
(see website for images and availability)
- Weight Limit: 400 lbs



Esports Xpressions Gaming Chair

38153 - no logo
38156 - w/ logo

- Zip in custom embroidered logo panel (6" x 9") - (38146)
- Superior back support for hours of sitting in total comfort
- Attractive, modern style to fit any decor
- 4-D adjustable arms with soft gel cushioning
- Height adjustable seat
- Removable and repositionable ergonomic memory foam cushions for the back and head
- Base inserts available in multiple colors
(see website for images and availability)
- Commercial-grade base, built to last in the toughest environments
- Stable and wide 28.5" star base
- Weight Limit: 350 lbs



7-Outlet Power Strip - 99024

- Electrical Rating: AC 125V, 15 Amps
- 1000 Joules surge capacity
- 12' cord length
- LED switch
- UL Listed
- Shipping weight: 1.9 lb [.86 kg]

Single Circuit Power Kits

(Plugs into 3-prong AC wall outlet)

3-prong
AC plug

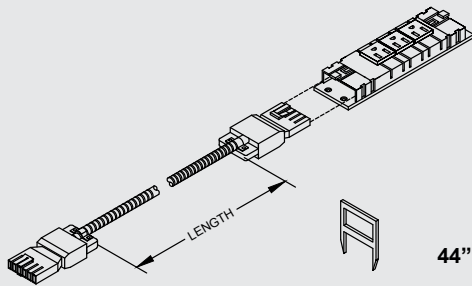

44" - 99066

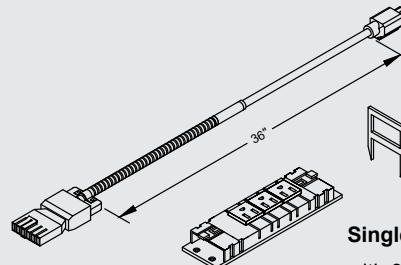

Single Circuit Power Feed - 99070
with 36" flexible cord and 3-prong AC plug

EP8 Kits

Provides isolated ground circuits
(requires hard-wiring)

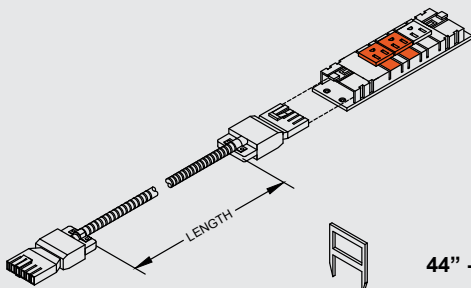

44" - 99009

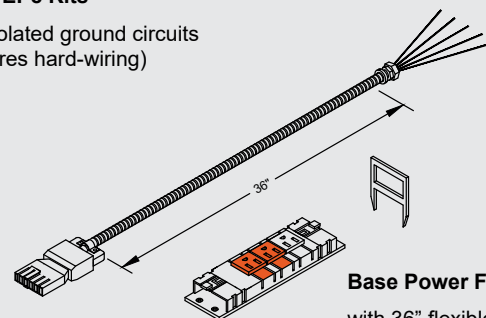

Base Power Feed - 99022
with 36" flexible cord

See spectrumfurniture.com for the latest accessories and detailed warranty information.

Warranty

We will make it right for you!

Thanks for choosing Spectrum! Spectrum is committed to provide complete customer satisfaction. Each of our products is manufactured from the best materials available and each product is stringently monitored throughout the production process through our P.A.C.E. program (Product Assurance to meet Customer Expectations).

We expressly warrant that Spectrum products will be of good quality and workmanship and free from defect for the period set out in the warranty from the date of delivery.

For a listing of all product specific warranty terms please visit our website at:

<https://www.spectrumfurniture.com/en/resources/purchasing-terms-warranty>

1-800-235-1262

Toll-free HELPLINE

spectrum@spectrumfurniture.com