

Assembly Instructions

⚠ Important ⚠

Before you begin, read and comply with all safety and operating instructions, and ensure all parts and correct quantities are included.

Any parts damaged during shipment must be reported within 5 days of receipt. To report information regarding missing parts or damage, to purchase parts or accessories, or if you have any questions, please contact us.

www.spectrumfurniture.com
800-235-1262, 715-723-6750

Thank you for purchasing Spectrum products!

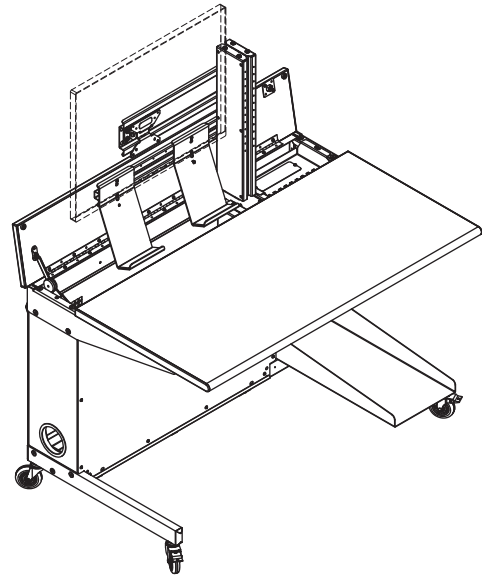

Components

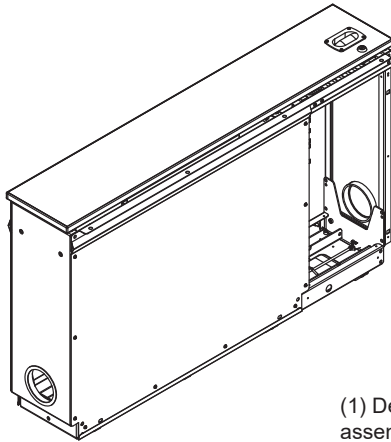

(1) Desk assembly

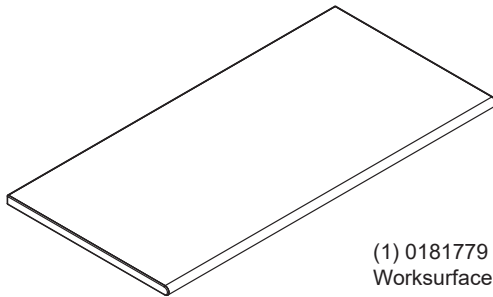

(1) 0181779 Worksurface

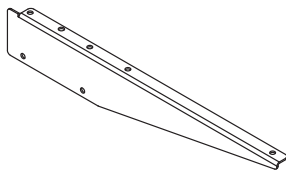

(1) 0181200 Left arm

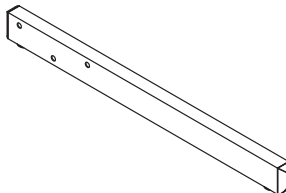

(2) 0181976 Foot

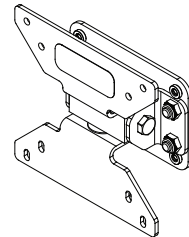

(1) 0107624 Swivel VESA Monitor Mount

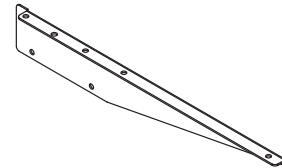

(1) 0181199 Right arm

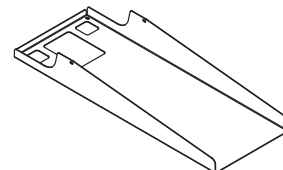

(1) 0181796 CPU tray

Esports Champions Desk 37432



20 min



X2



Assembly tip: Do not tighten component fasteners completely until all have been installed. Keeping them loose will help with alignment between parts during assembly.

Glide hardware

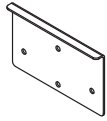

(2) 0181996
Outer foot
bracket

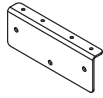

(2) 0182159
Inner foot
bracket

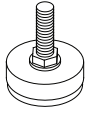

(4) 037779
5-16-18 Glide



(6) 0106543
1/4-20 Keps nut

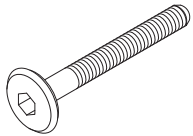

(6) 053310
1/4-20 x 40mm
JC bolt



(12) 0100167
8-32 x 1/2" PH
Thrd ctg

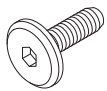

(14) 044541
1/4-20 x 20mm
JC bolt



(8) 0101382
#14 x 7/8"
PHSM

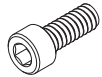

(4) 0107683
10-24 x 1/2" SHCS
(for VESA mount)



(1) 025039
4mm hex
wrench

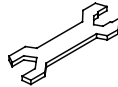

(1) 025069
Glide wrench

Caster hardware

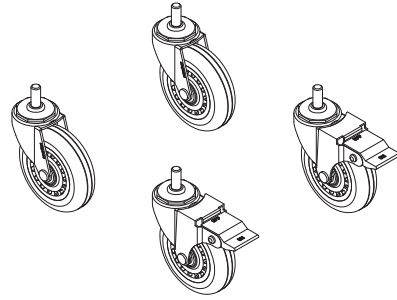

(1) Premium
3" caster set

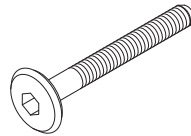

(6) 053310
1/4-20 x 40mm
JC bolt

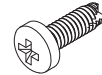

(4) 0100167
8-32 x 1/2" PH
Thrd ctg

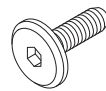

(8) 044541
1/4-20 x 20mm
JC bolt



(8) 0101382
#14 x 7/8"
PHSM



(4) 0107683
10-24 x 1/2" SHCS
(for VESA mount)



(1) 025039
4mm hex
wrench

1

Install glides or casters

Glides

1. Install (2) glides in each foot. Adjustments can be made later if necessary for uneven floors.
2. Repeat on second foot.

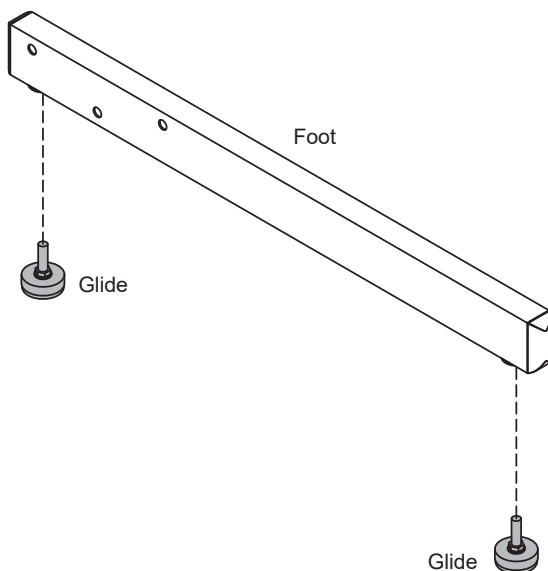

Casters

1. Install casters as shown. Note the non-locking caster installs on the end of the foot with holes.
2. Tighten securely.
3. Repeat on second foot.

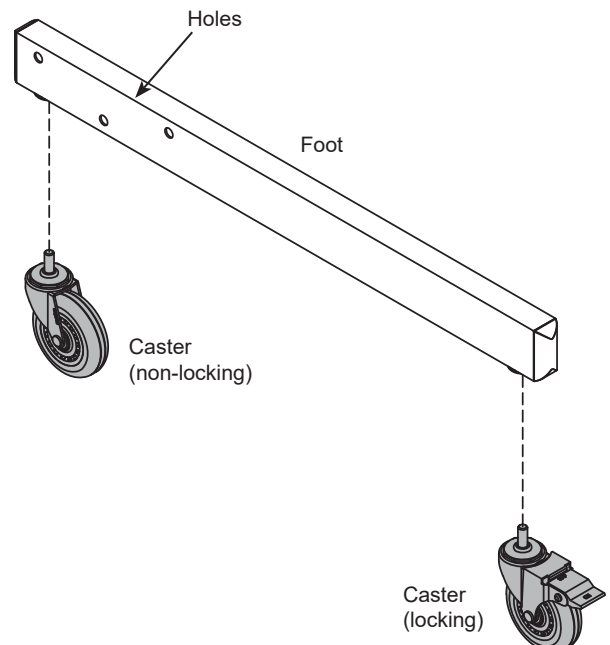

Glides

1. Carefully tip the desk assembly onto the audience-side to access the bottom.
2. Attach the inner foot bracket as shown with (4) 8-32 x 1/2" PH Thrd ctg screws. Do not tighten screws yet.
3. Attach the outer foot bracket as shown with (3) 1/4-20 x 20mm JC bolts. Do not tighten screws yet.
4. Repeat on other foot.

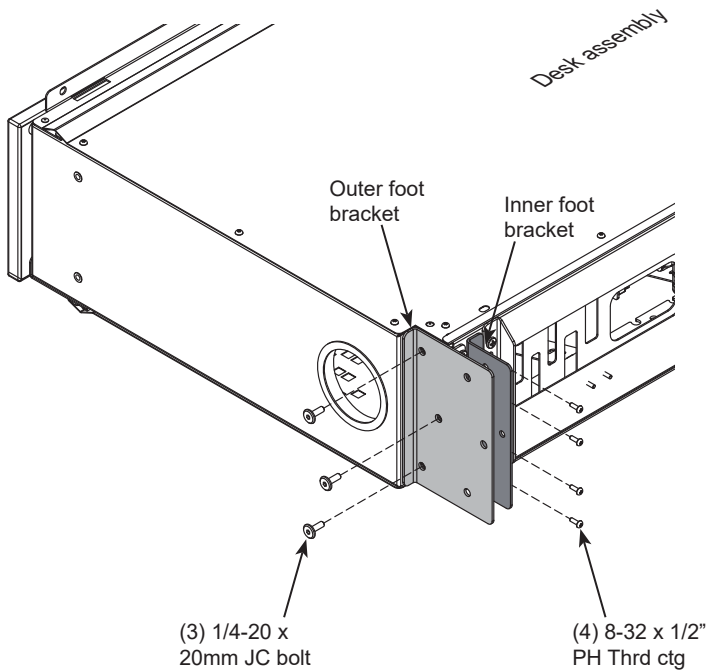

5. Attach foot assembly with (3) 1/4-20 x 40mm JC bolts.
6. Tighten all screws.
7. Repeat on other foot.
8. Tip desk upright when complete.

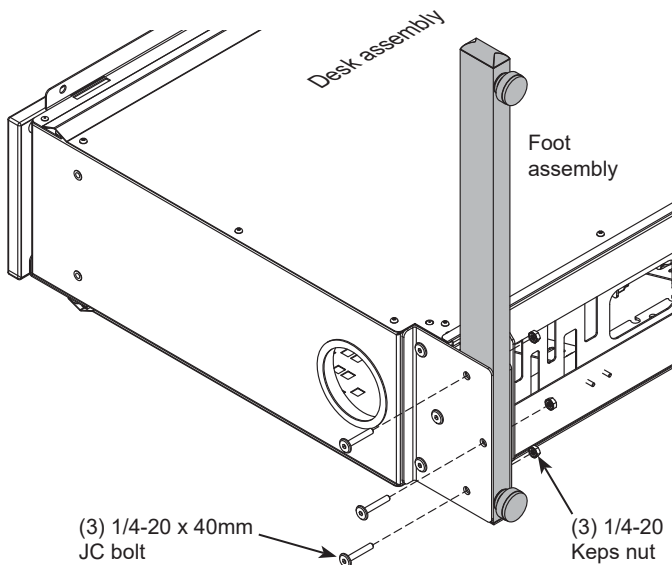
Casters

1. Carefully tip the desk assembly onto the audience-side to access the bottom.
2. Attach the foot assembly with (3) 1/4-20 x 40mm JC bolts.
3. Repeat on other foot.

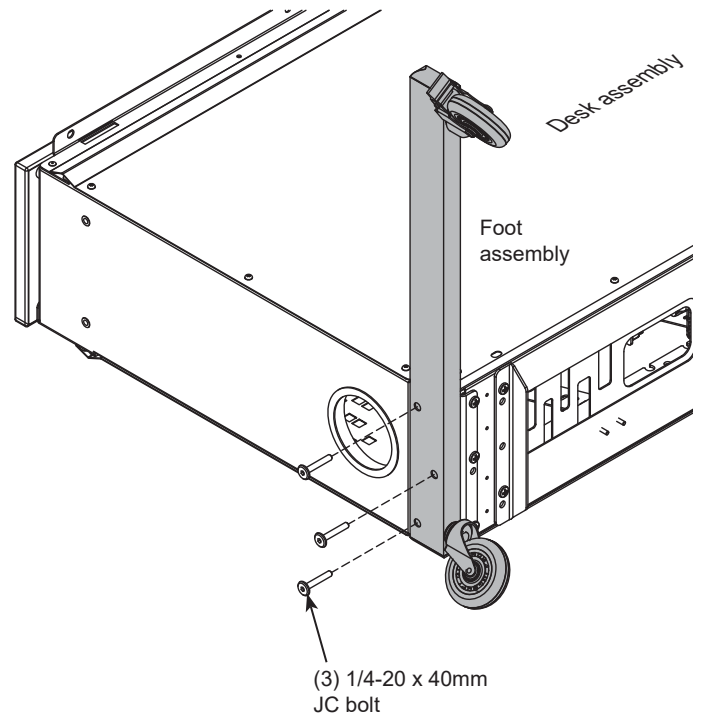

3 Attach CPU tray

1. Set the CPU tray into the opening in the desk and align the (4) mounting holes.
2. Secure the tray with (4) 8-32 x 1/2" PH Thrd ctg screws and tighten securely.

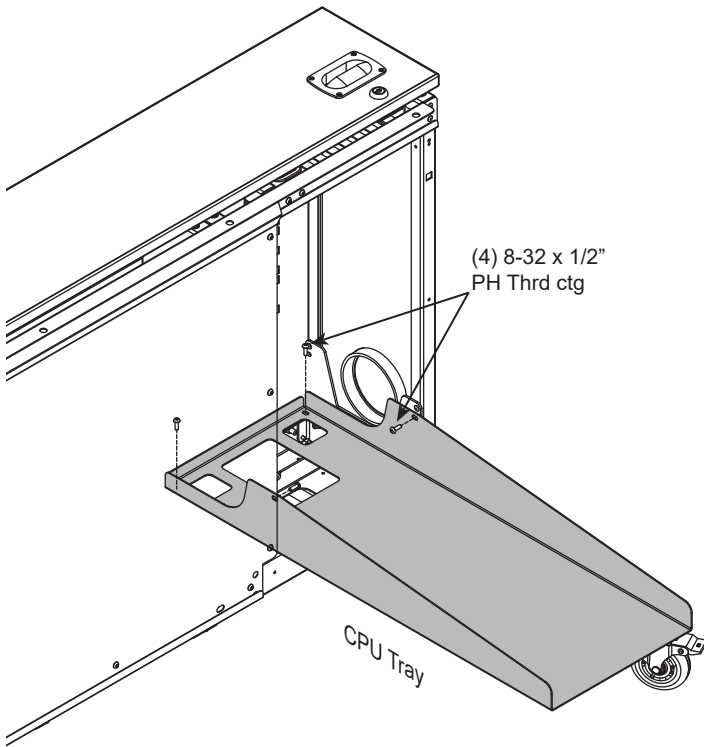

4 Remove storage tray

1. Open desk lid.
2. Loosen the (2) storage tray mounting screws.
3. Push the tray back to unlock the keyholes and lift out.

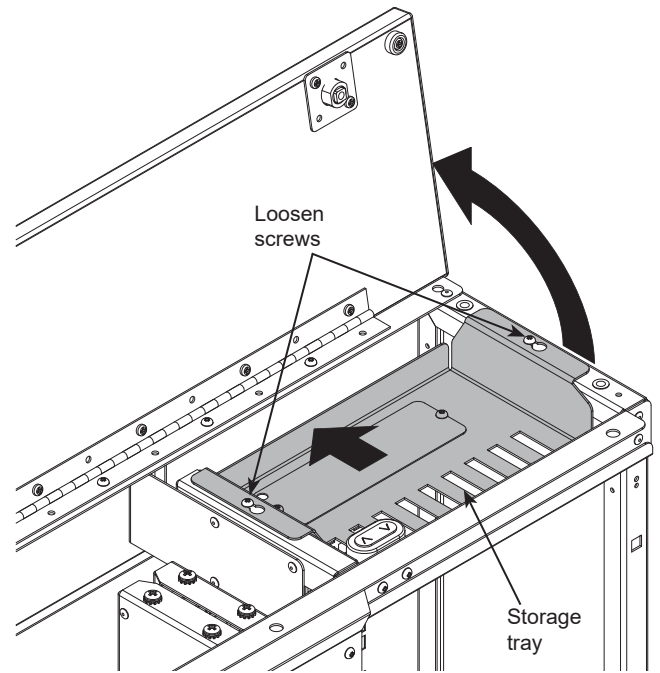

5 Attach arms to desk

1. Orient the left and right arms as shown with the flanges facing inward.
2. Secure each arm with (4) 1/4-20 x 20mm JC bolts and tighten securely.
3. Replace storage tray from step 4.

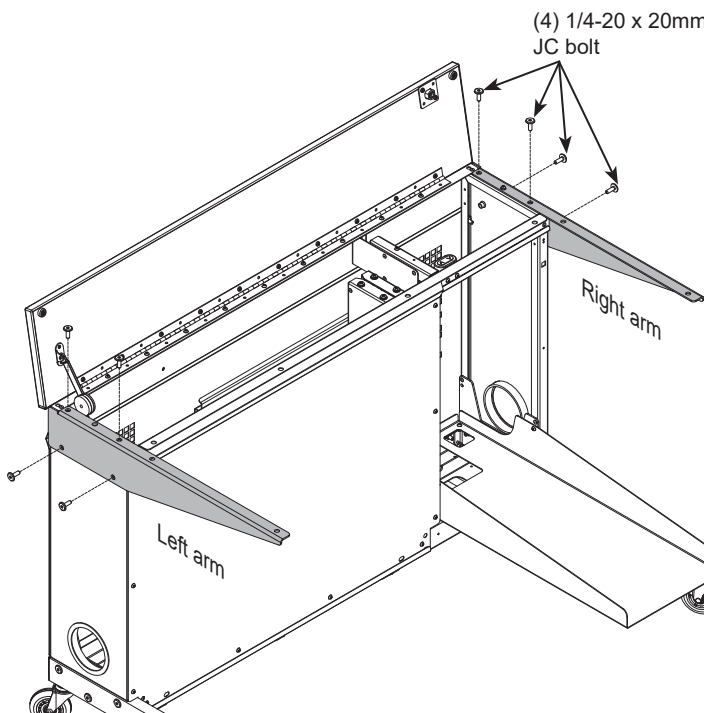

6 Attach worksurface

1. Set the worksurface onto the arms and align the mounting holes.
2. Attach with (8) #14 x 7/8" PHSM, but do not overtighten.

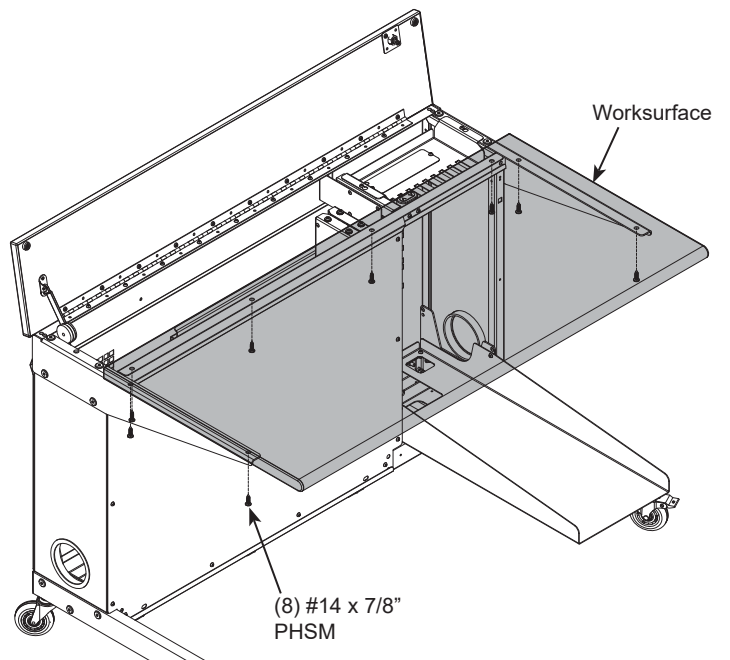

Keyboard storage

The keyboard storage brackets store the keyboard under the monitor and can be adjusted left and right to support most keyboards. The keyboard should rest in the brackets without interference with the monitor, worksurface, or column. If bracket adjustment is necessary, remove the (2) mounting screws to relocate the bracket to another mounting hole along the rail, then retighten.

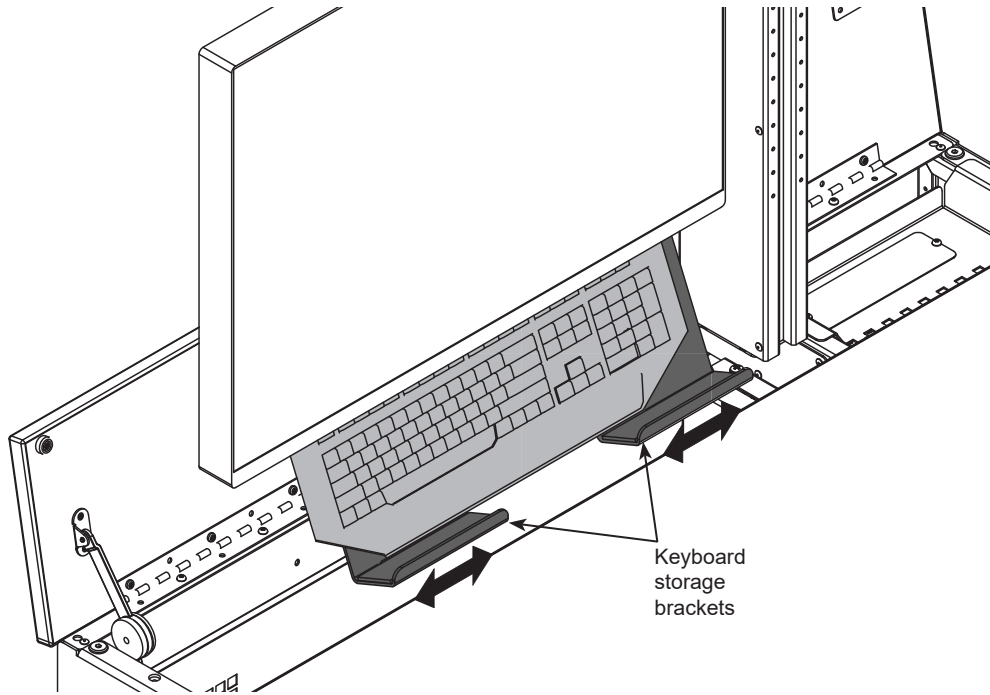

Removing audience-side panel

1. The panel is designed for easy removal using keyhole slots and 1/4-20 JC bolts. If the bolts are tight, loosen slightly with a 4mm hex wrench.
2. Remove the (2) upper JC bolts and lift up on panel to unlock from the keyhole slots.
2. Lift off the panel.

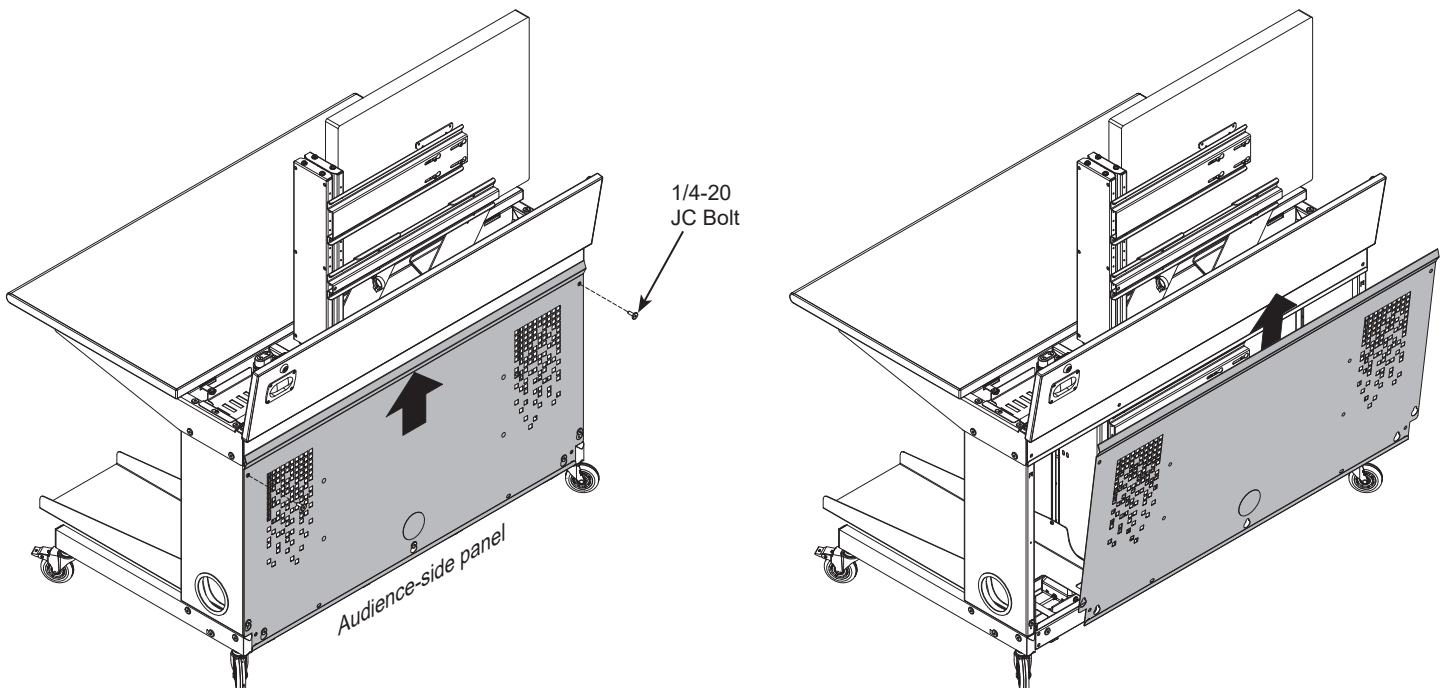

Monitor installation

1. Attach the VESA mount (butterfly-shaped portion) to the back of your flat panel monitor with (4) M4 x 12mm PHM screws (not included). (Holes on top, slots on bottom). Note: It will be necessary to remove the standard base that comes with the monitor to use the VESA mount.
2. Thread (4) 10-24 x 1/2" SHC screws into the rectangular plate at the back of the VESA mount. Leave about 1/8" between each screw head and the plate.

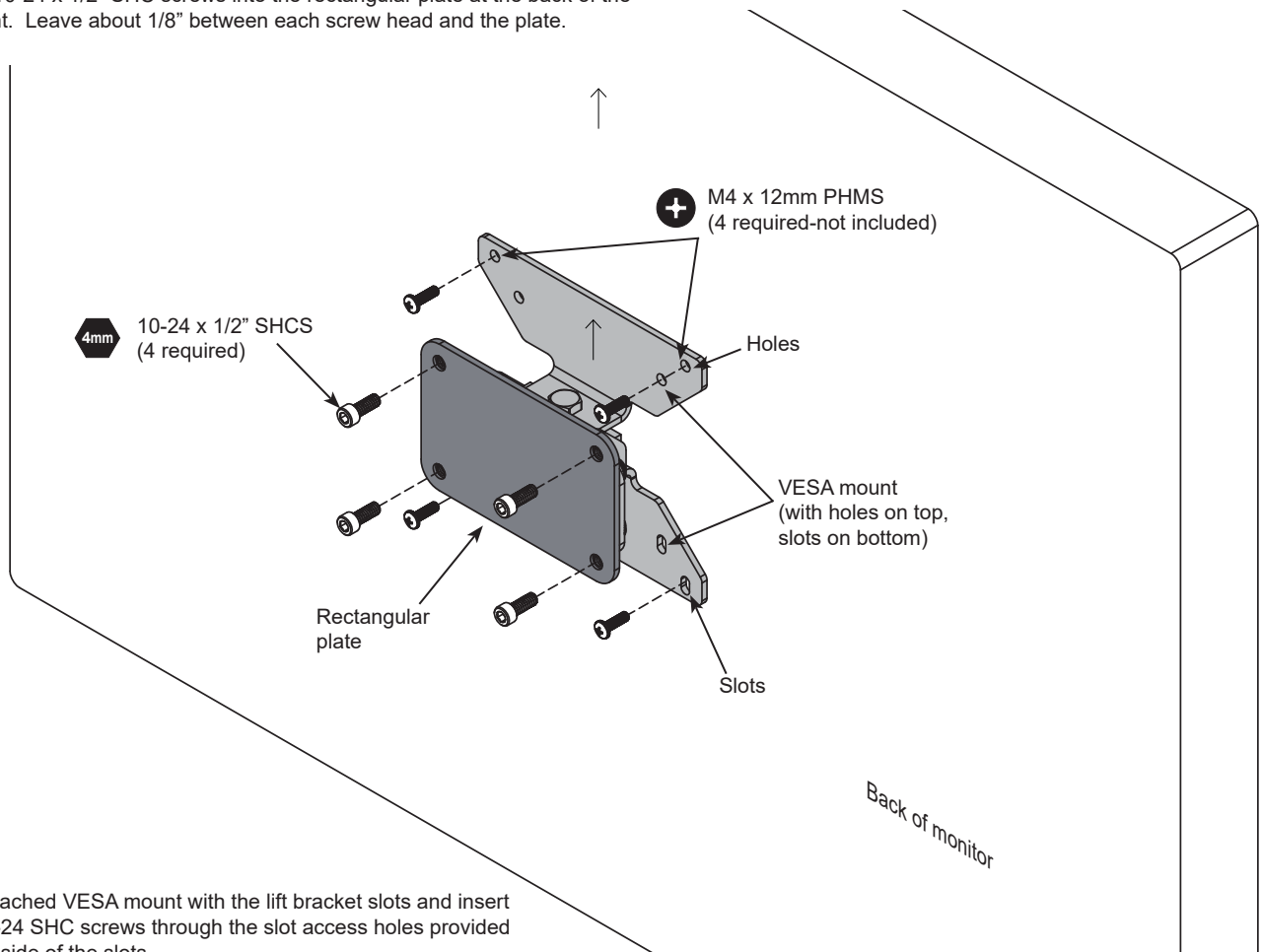

3. Align the attached VESA mount with the lift bracket slots and insert all (4) of 10-24 SHC screws through the slot access holes provided on the right-side of the slots.
4. Slide the monitor assembly to the left making leaving at least a 1/4" gap between the monitor and lift column.
5. Tighten all (4) 10-24 SHC screws to secure.

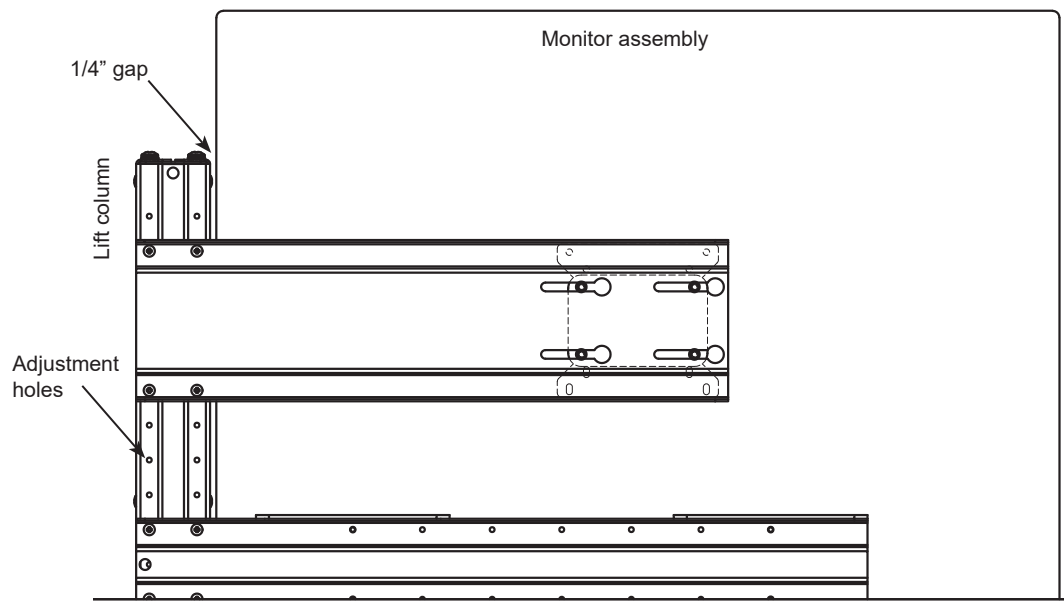

Cord management

1. With the back panel removed, connect the necessary monitor, keyboard, and mouse cords above the worksurface.
2. Use the wire loom attached to the back of the keyboard tray to route wire and cables down to the bottom of the desk. The wire loom keeps cords together and protects them while the monitor is being raised and lowered. To access the wire loom use a flat head screwdriver to pry open and release each loom clip
3. Route wires and cords down through the loom.
4. Be sure to provide enough slack in the cords during normal use and for left / right mouse locations.

Top View

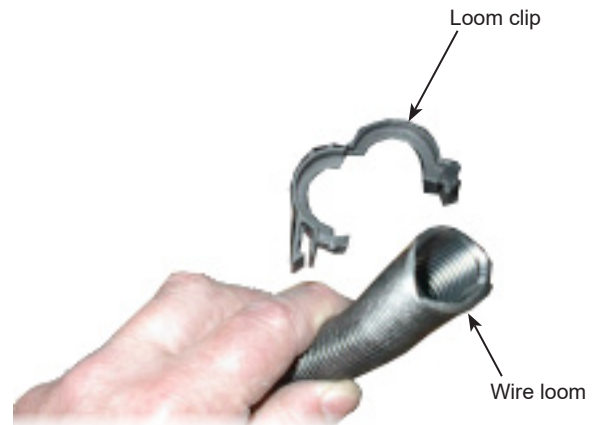
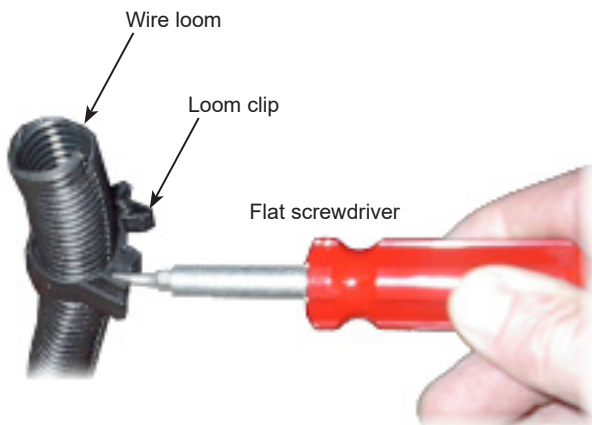
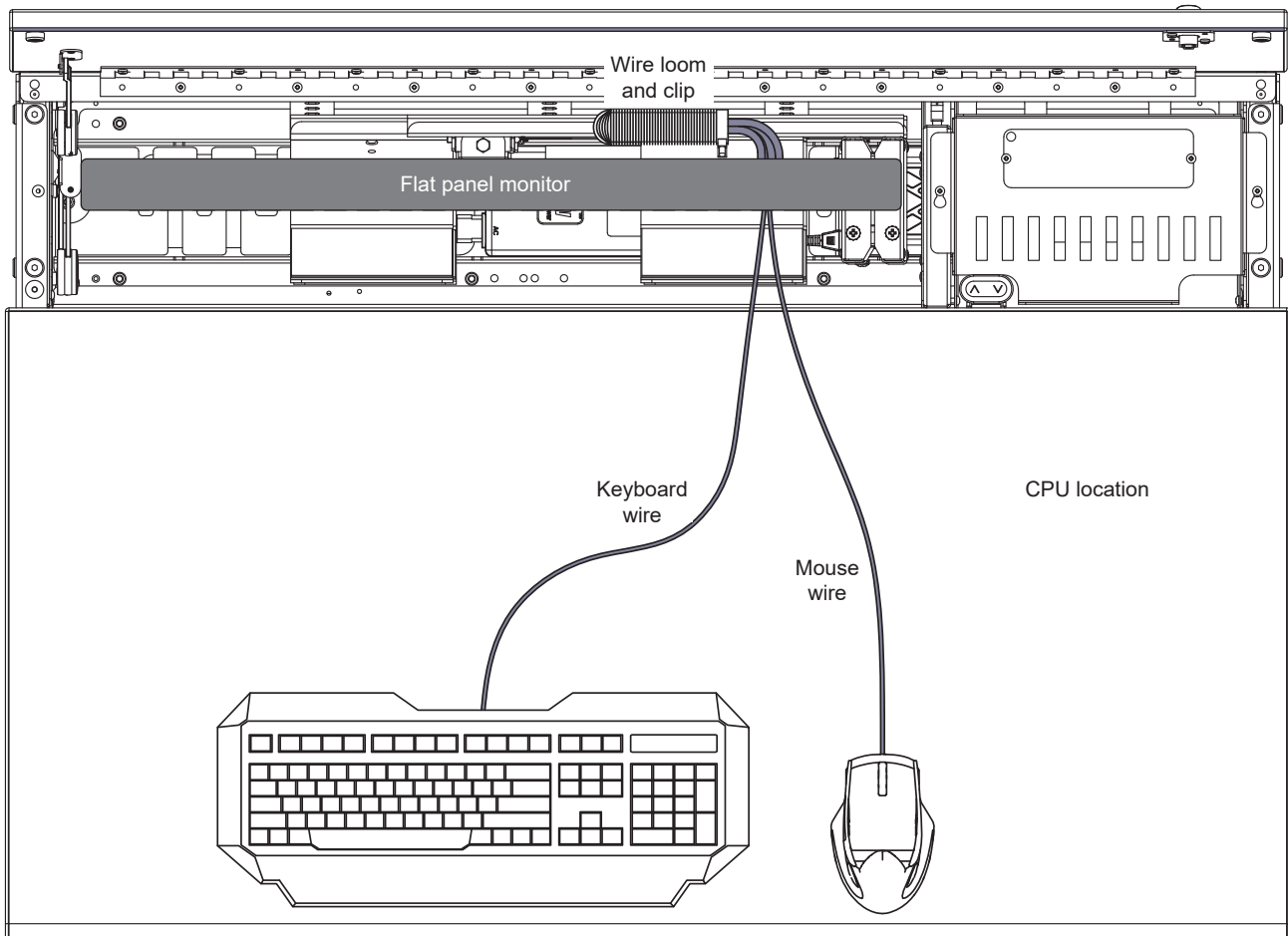

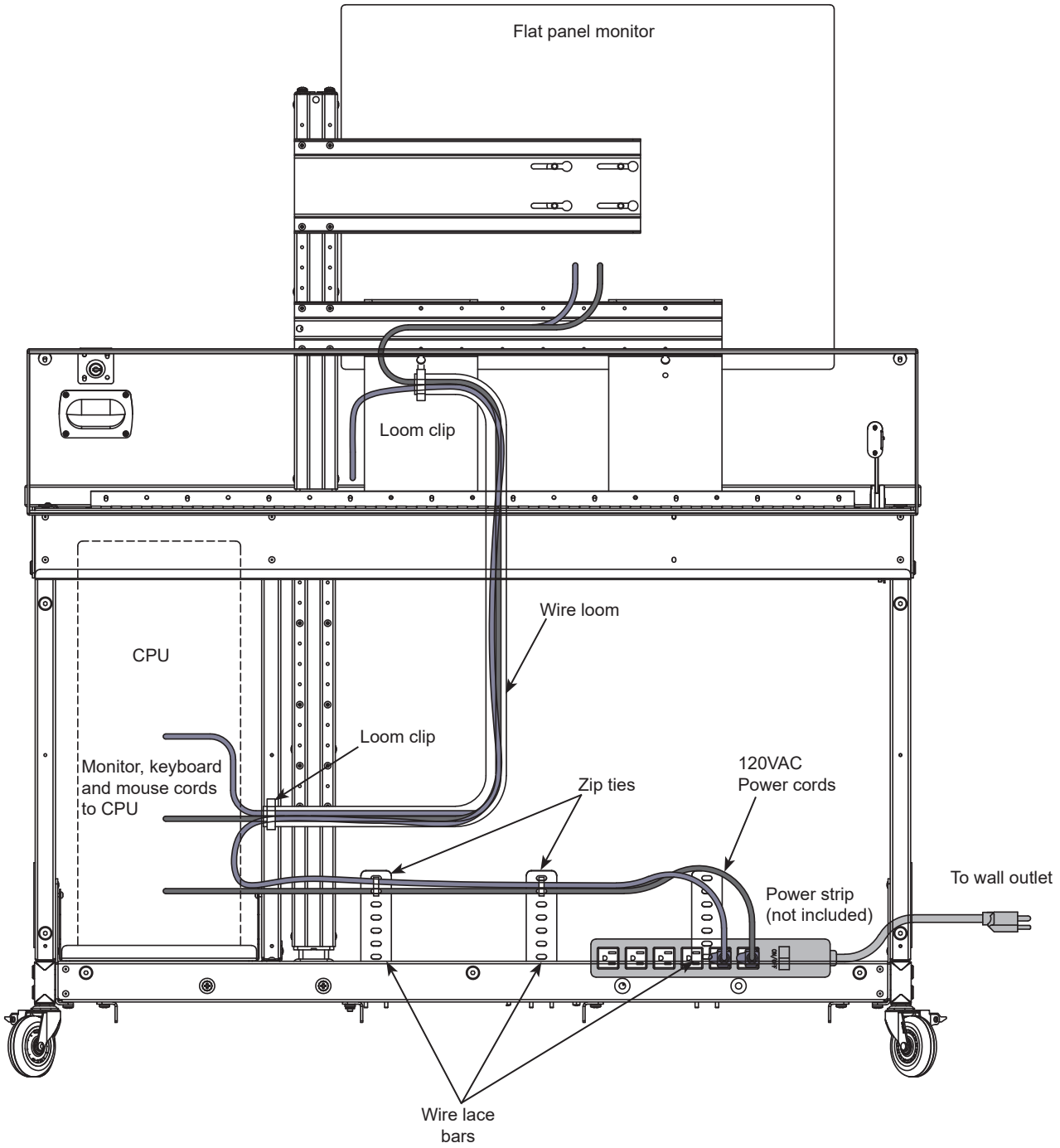

Optional power module installation

1. To install an optional power module, loosen the (2) keyhole screws securing the storage tray.
2. Lift the storage tray out of the desk.

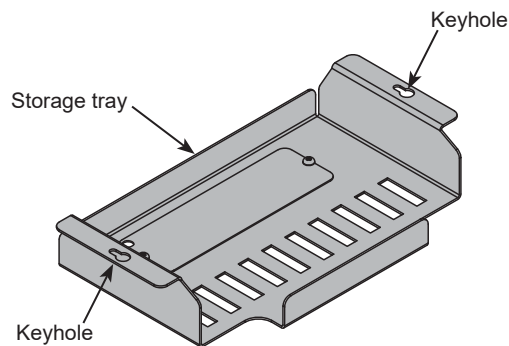

3. Remove the screws and cover plate from the storage tray.
4. Remove the (2) clamp flanges from the power module. (Not shown).

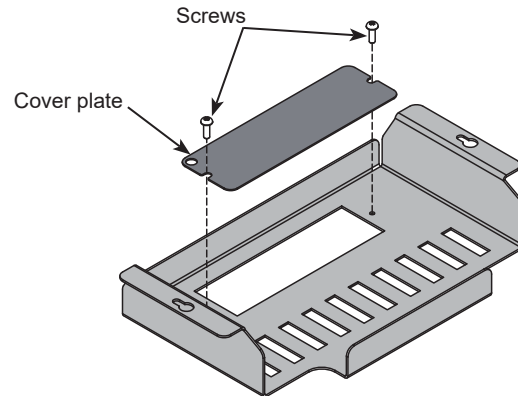

5. Feed the power cord and power module into the tray opening.
6. Replace the flanges on the power module and tighten to secure the power module to the tray.

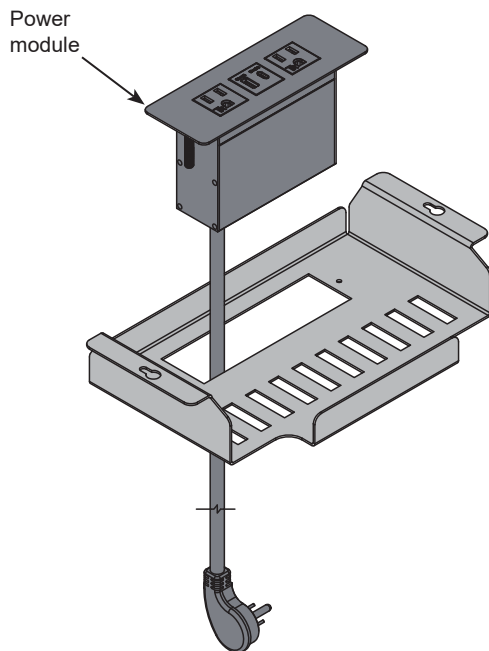

7. Set the storage tray assembly back into the desk opening and lock into the (2) keyholes.
8. Re-tighten the keyhole mounting screws.

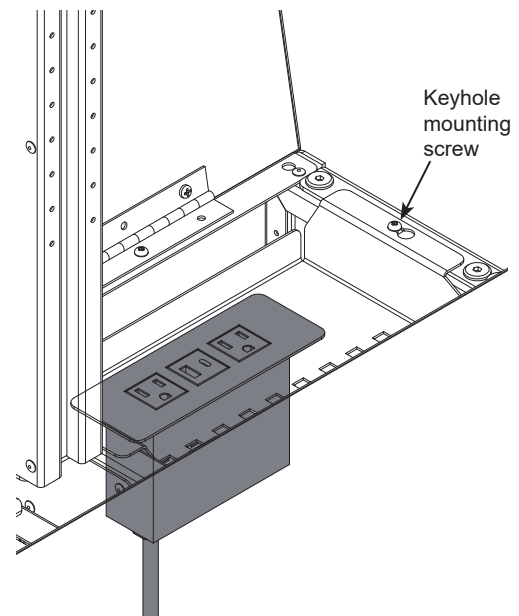

Maintenance

After approximately 300 cycles of opening and closing, the friction dampener on the worksurface lid should be retightened to 13 in-lb using a torque wrench with a 4mm hex driver. If a torque wrench is unavailable, tighten the friction damper with a 4mm hex wrench 1/8 turn at a time and test. The correct adjustment is when the lid slows down between 2-4" from closure.

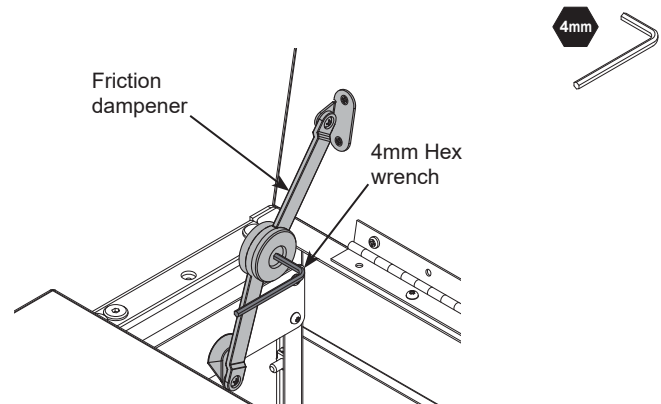

Accessories

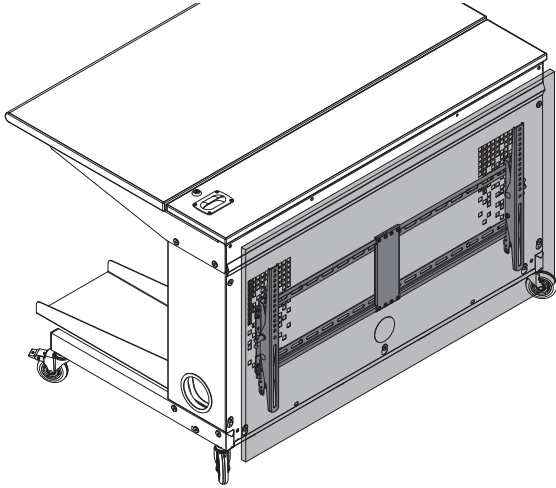

Audience-side display mount - 95557

- Provides display monitor mounting on audience-side
- Adjustable VESA-compatible
- Accommodates most monitors up to 50" diag (not included)
- Customer-installed
- Unit weight: 8 lb [3.6 kg]
- Shipping weight: 9 lb [4.1 kg]

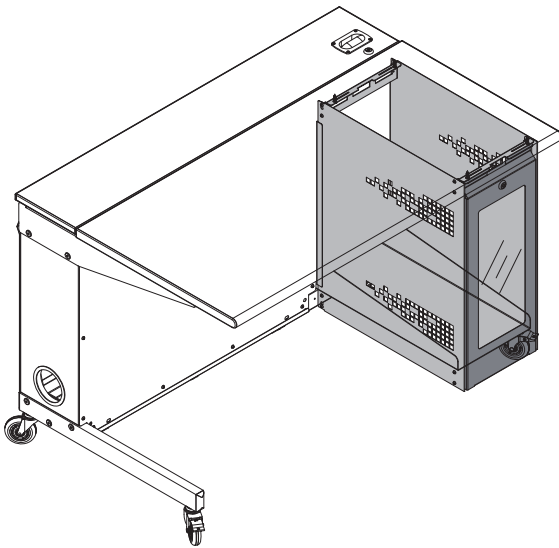

Locking CPU enclosure - 95556

- Dimensions: 10"W [25.4 cm] x 19.88"D [50.5 cm] x 24.25"H [61.6 cm]
- Black powder coat
- Locking acrylic front panel
- Ventilated side panels
- Customer-installed
- Unit weight: 14 lb [6.4 kg]
- Shipping weight: 16 lb [7.3 kg]

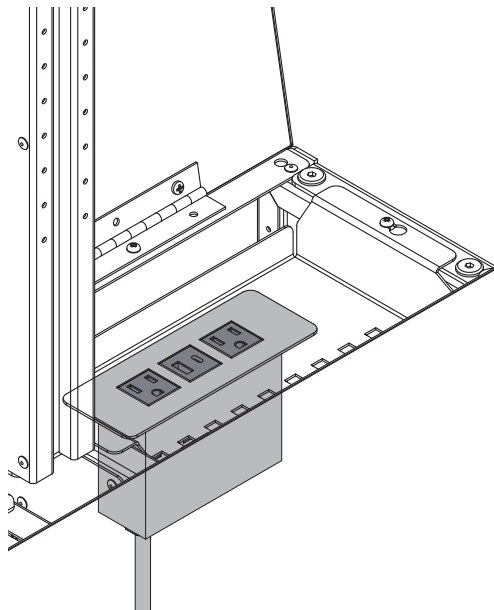

USB-C Power Module - 99075

- Mounts under flip-up lid for easy access
- (2) AC power outlets (tamper-resistant)
- (1) USB charge port
- (1) USB-C charge port
- Aluminum housing and flange
- Thumbscrew clamps
- ETL-certified
- Available in black, silver, or white
- Customer-installed

Cutout required:	5.65"W x 1.65"D cutout exists under flip-up lid
Power cord:	10' [305 cm] 14AWG *3C power cord
Power receptacles:	125V, 60hz, 15A tamper-resistant
USB-C charging port:	2.4A (12W) (non data compatible)
USB charging port:	2.1A (10.5W) (non data compatible)
Dimensions:	6.38"W [16.2 cm] x 2.36"D [6 cm] x 3.54"H [9 cm]
Unit weight:	2 lb [.9 kg]
Shipping weight:	2.35 lb [1 kg]





Esports Genova Gaming Chair

38151
38320

- Rugged carbon PVC seat stands up to hours of use
- Optimize ergonomics with the height adjustable seat
- Durable, 2D high-grade plastic arm rests can be adjusted quickly, in both height and rotation
- Fully reclining, 180° tilt mechanism allows you to lay back to stretch or rest up for the next game
- Back and neck pillows are adjustable to provide superior support for extended tournament play
- Available in multiple colors (*see website for images and availability*)
- Weight Limit: 400 lbs



Esports Xpressions Gaming Chair

38153 - no logo
38156 - w/ logo

- Zip in custom embroidered logo panel (6" x 9") - (38146)
- Superior back support for hours of sitting in total comfort
- Attractive, modern style to fit any decor
- 4-D adjustable arms with soft gel cushioning
- Height adjustable seat
- Removable and repositionable ergonomic memory foam cushions for the back and head
- Base inserts available in multiple colors (*see website for images and availability*)
- Commercial-grade base, built to last in the toughest environments
- Stable and wide 28.5" star base
- Weight Limit: 350 lbs



7-Outlet Power Strip - 99024

- Electrical Rating: AC 125V, 15 Amps
- 1000 Joules surge capacity
- 12' cord length
- LED switch
- UL Listed
- Shipping weight: 1.9 lb [.86 kg]

Single Circuit Power Kits

(Plugs into 3-prong AC wall outlet)

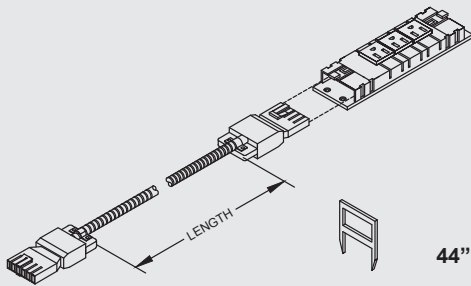

44" - 99066

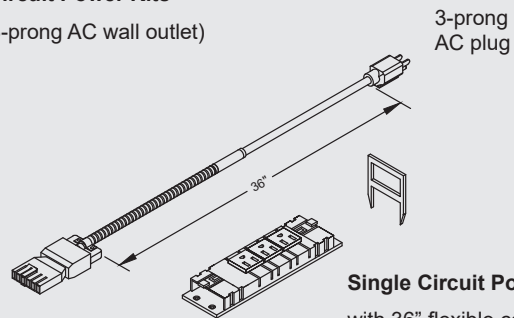

Single Circuit Power Feed - 99070
with 36" flexible cord and 3-prong AC plug

EP8 Kits

Provides isolated ground circuits
(requires hard-wiring)

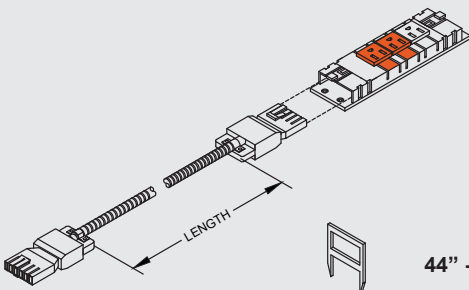

44" - 99009

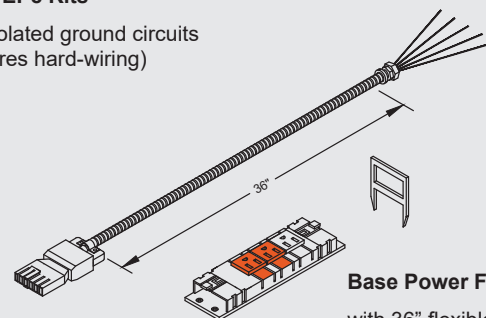

Base Power Feed - 99022
with 36" flexible cord

See spectrumfurniture.com for the latest accessories and detailed warranty information.



Important Safety & Care Information



- Read this owner's manual before assembly or operation.
- Do not allow children to move the table.
- For indoor use only. Do not install or store the table where it will be exposed to moisture.
- Do not block the ventilation openings.
- Do not allow anyone to sit, stand, or climb on the table.
- Use a damp, soft-cloth, or sponge, with mild soap or detergent solution to clean dirty surfaces. Do not use harsh solvents or abrasives.
- This table is intended for institutional use. It does not have any user-serviceable parts or user-maintenance requirements. If servicing is necessary, please contact Spectrum Industries for assistance.

Warning - Relocating audio and/or video equipment to furniture not specifically designed to support audio and/or video equipment may result in death or serious injury due to the furnishing collapsing or over turning onto a child.

Warning - Death or serious injury may occur when children climb on audio and/or video equipment furniture. A remote control or toys placed on the furnishing may encourage a child to climb on the furnishing and as a result the furnishing may tip over on to the child.

General Electrical Safety:

- Keep power switches in the OFF position before plugging or unplugging from the wall outlet.
- Be sure total device / equipment load does not exceed 12-amps.
- Do not plug power cords into an extension cord.
- Inspect power cords for damage before each use. Do not use cords that are damaged.
- Unplug power cord from electrical outlet by gripping the cord-do not unplug by pulling only on the cord.
- Do not step on, drive over, drag, or place objects on power cords.
- For added safety, plug into a grounded outlet controlled by a GFI (Ground Fault Interrupter) circuit breaker.
- Damaged electrical components can create significant hazards to users and is not covered by the warranty. Repairs should always be performed by a qualified electrician.
- Electrical devices are not toys. Children are often unaware of the hazards associated with electrical devices. This table must always be used by adults or with adult supervision.

Warranty

We will make it right for you!

Thanks for choosing Spectrum! Spectrum is committed to provide complete customer satisfaction. Each of our products is manufactured from the best materials available and each product is stringently monitored throughout the production process through our P.A.C.E. program (Product Assurance to meet Customer Expectations).

We expressly warrant that Spectrum products will be of good quality and workmanship and free from defect for the period set out in the warranty from the date of delivery.

For a listing of all product specific warranty terms please visit our website at:

<https://www.spectrumfurniture.com/en/resources/purchasing-terms-warranty>

1-800-235-1262

Toll-free HELPLINE

spectrum@spectrumfurniture.com