

## Technical Specifications

55570

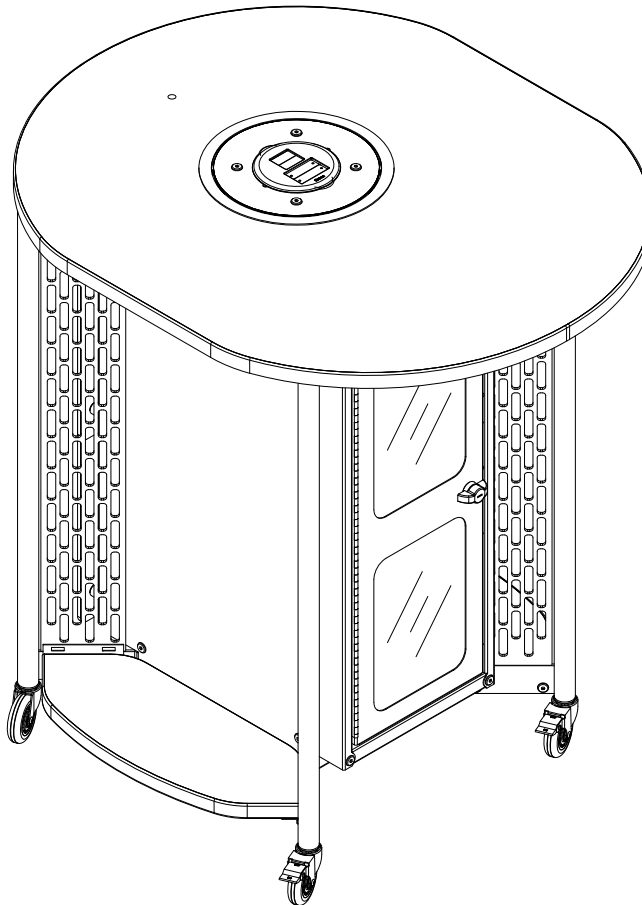

Customize your teaching approach to accommodate your students' diverse learning environments with the versatile Hyflex Lectern. Equipped with casters and a rotating worksurface, it provides easy access to technology while fostering active engagement with students.

## Features and Benefits

- Large, 270° rotating worksurface provides space and flexibility
- Multiple worksurface interface plates available to meet your specific AV needs
- 3/8" worksurface hole for mounting optional monitor
- 6RU rack rails included in rack cabinet
- Ventilated panels keep devices cool, preventing overheating, and extending device life
- Cables are organized in the center rack, keeping the worksurface clutter-free
- Locking, instructor-side door provides security, while the acrylic windows allow for easy monitoring of internal components
- Locking, removable back panel provides easy access to equipment
- Premium 3" casters (2 locking & 2 non-locking) offer smooth mobility
- Includes two backpack hooks (one on each side of the lectern) keep belongings mobile and out of the way
- Two foot shelves provide additional storage space, when needed
- Worksurface vinyl edging protects walls and furniture
- Two optional logo panel sizes for school branding with convenient magnetic mounting
- Optional monitor arms can be thru-mounted to worksurface
- Scratch and impact-resistant high-pressure laminate worksurface
- Durable powder coated steel chassis provides a long-lasting finish
- Available in Expressions metal and laminate finishes
- Center rack cabinet is black
- Each unit is factory-assembled with casters, packaged and shipped on its own skid. Worksurface is attached by customer.

### Color Options

Available in Spectrum Expressions colors.  
See [spectrumfurniture.com](https://www.spectrumfurniture.com) for complete color information.

# Construction

- The worksurface is constructed from 1" thick NAF (no added formaldehyde) composite board with .030" [.762mm] high-pressure laminate on one face, and balancing black laminate on the opposing face
- Worksurface edges are covered with vinyl edgeband
- All metal components are finished with a scratch-resistant powder coat epoxy
- Each unit is factory-assembled with casters, packaged and shipped on its own 32" skid. Worksurface is attached by customer.

# Specifications

Worksurface rotation	270° (135° left, 135° right)
Rack rail	6RU on instructor-side
Premium swivel casters (2 locking, 2 non-locking)	<ul style="list-style-type: none"> <li>• Diameter: 3" [7.62 cm]</li> <li>• Weight capacity: 120 lb [54.5 kg] each</li> </ul>
Certifications / Compliance	Meets or exceeds applicable ANSI-BIFMA test standards
Unit weight (nominal)	148 lb [67.2 kg]
Shipping weight (nominal)	180 lb [81.7 kg]

Specifications subject to change without notice

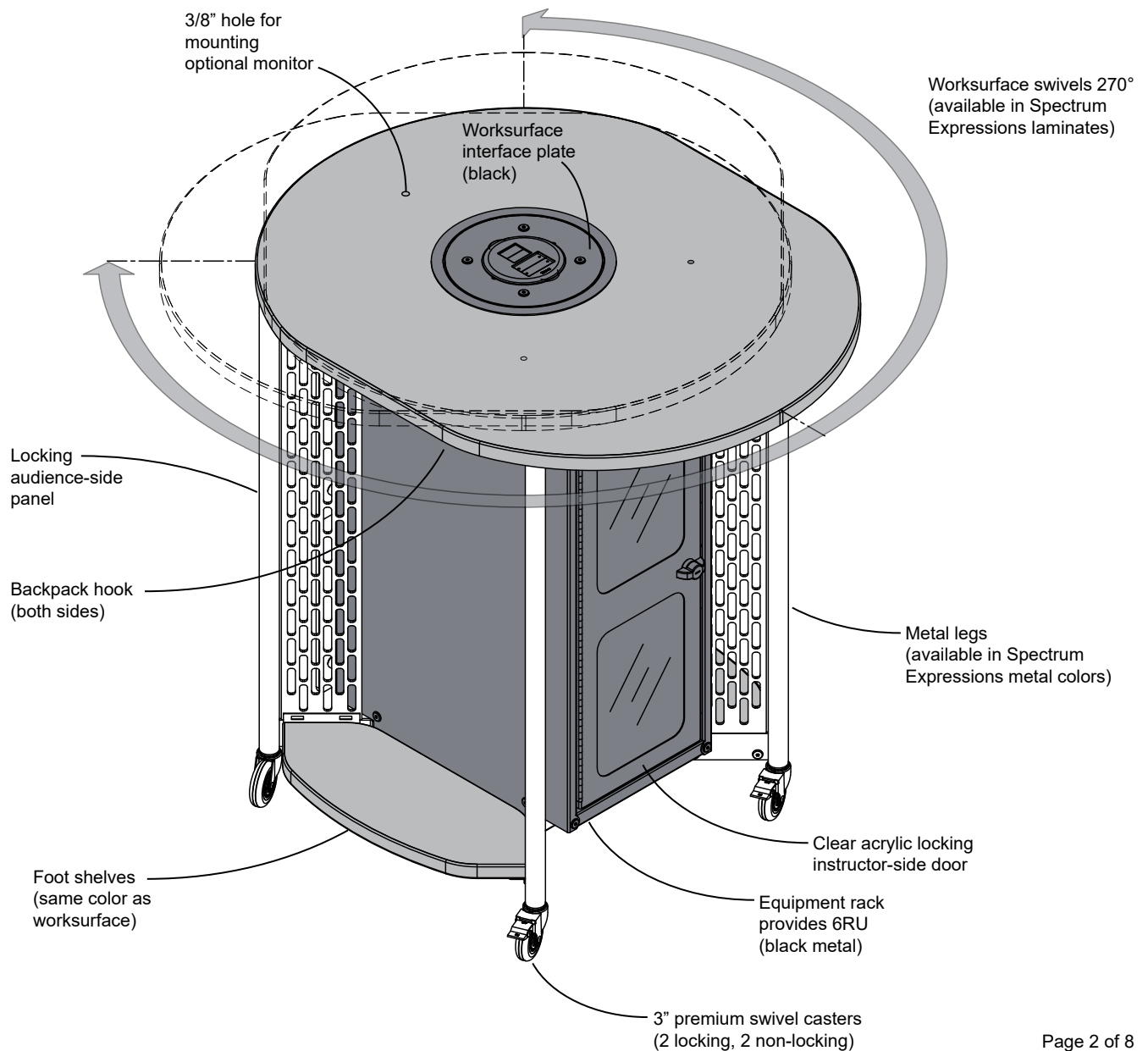

## Worksurface interface options

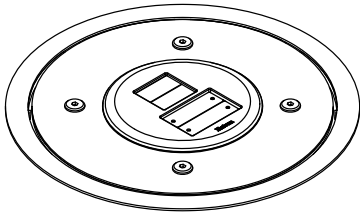

**Cable Cubby 100**  
(CC100 not included)

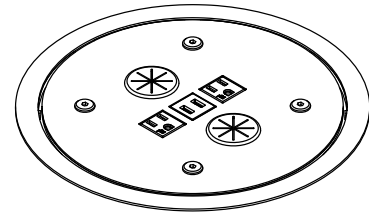

**Dock 1100**  
(2 AC outlets, 2 USB-C ports)

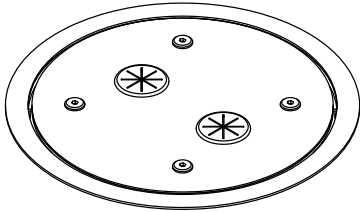

**Grommet**

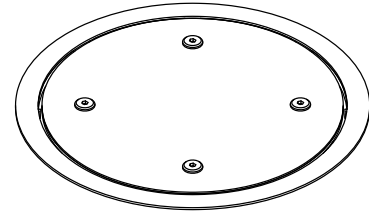

**Custom blank**  
(6" diameter, and 12" depth of available space)

Note: Spectrum can customize a blank interface panel to your device specifications within the 6" diameter available as long as there is clearance of objects under the worksurface.

**Contact Spectrum for customizing details.**

## Premium 3" casters

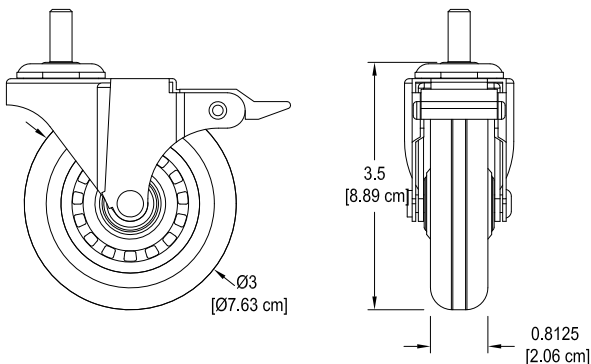
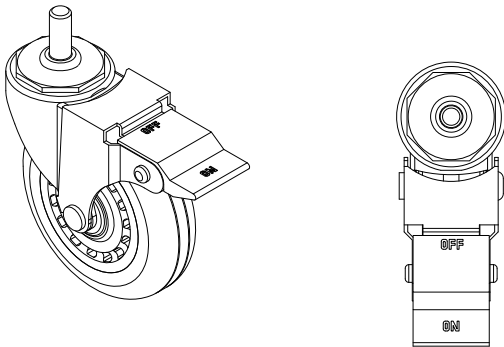

## Worksurface edge

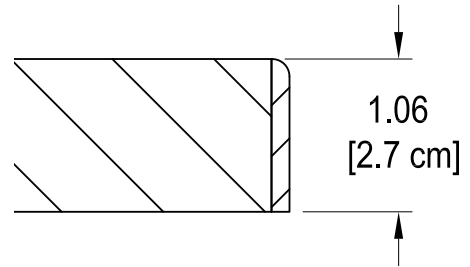

Hyflex Lectern

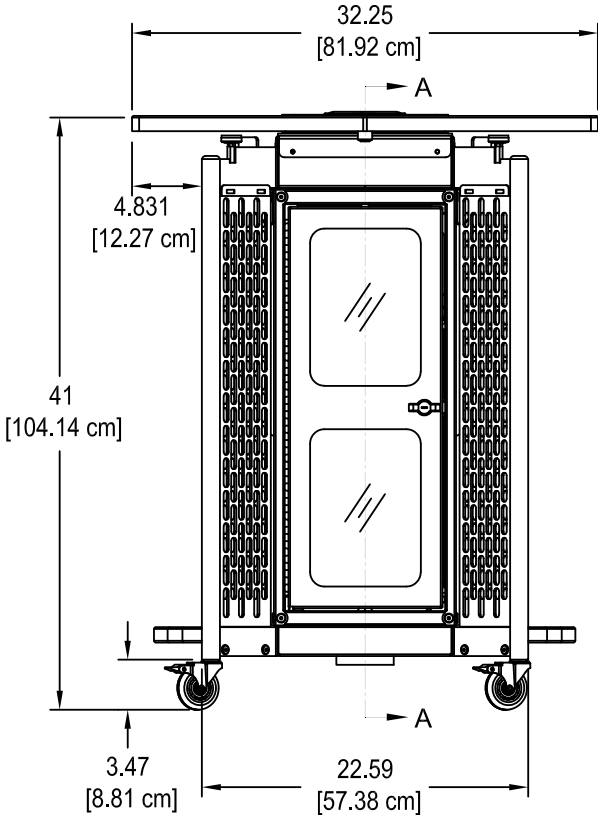
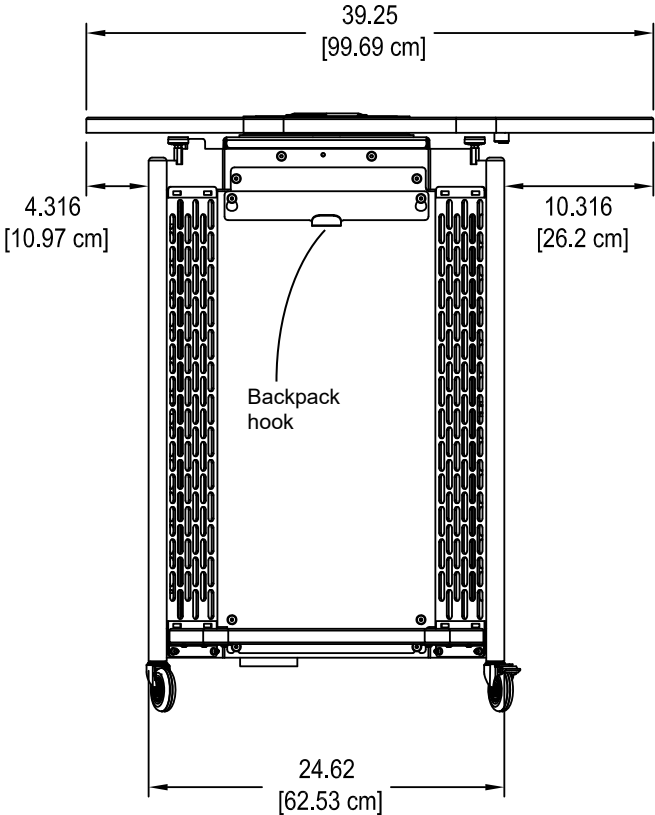
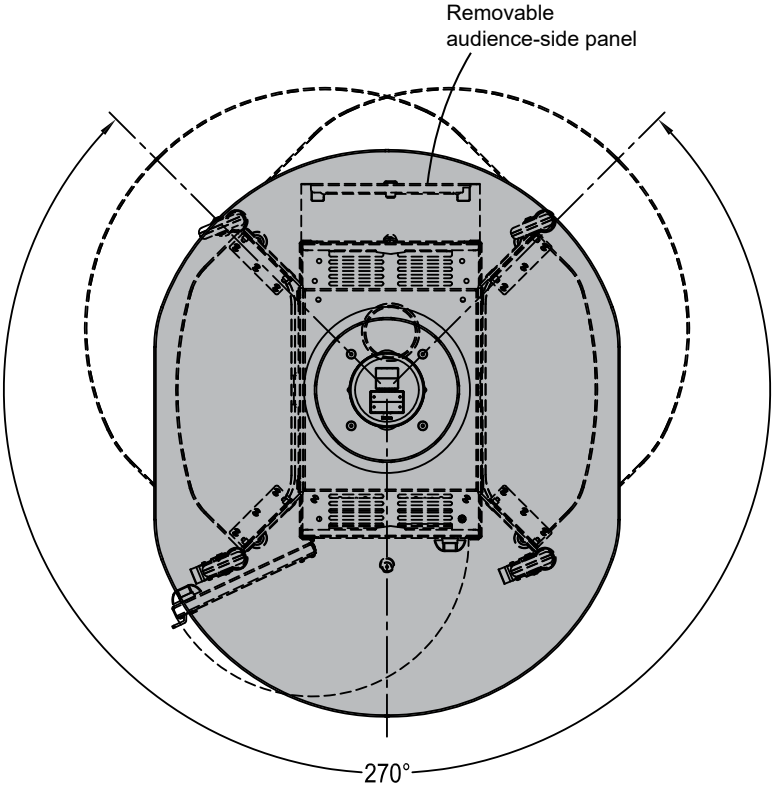
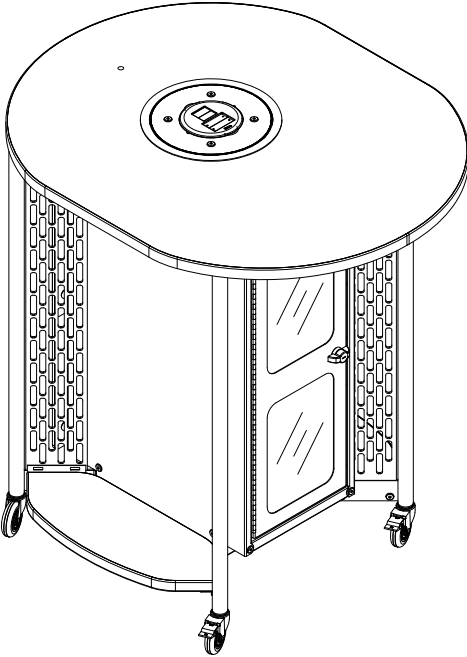

instructor-side View

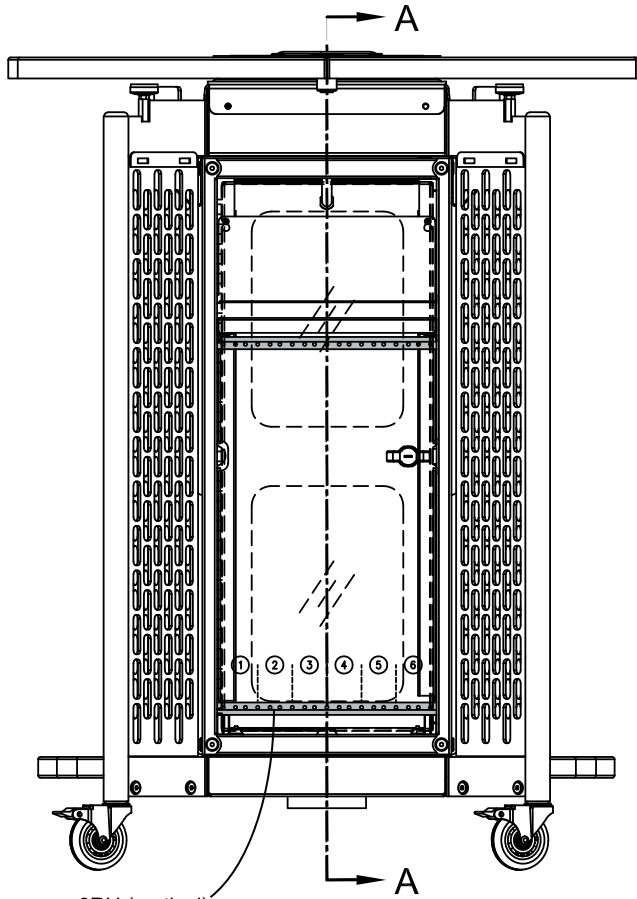

6RU (vertical)

Section View A-A

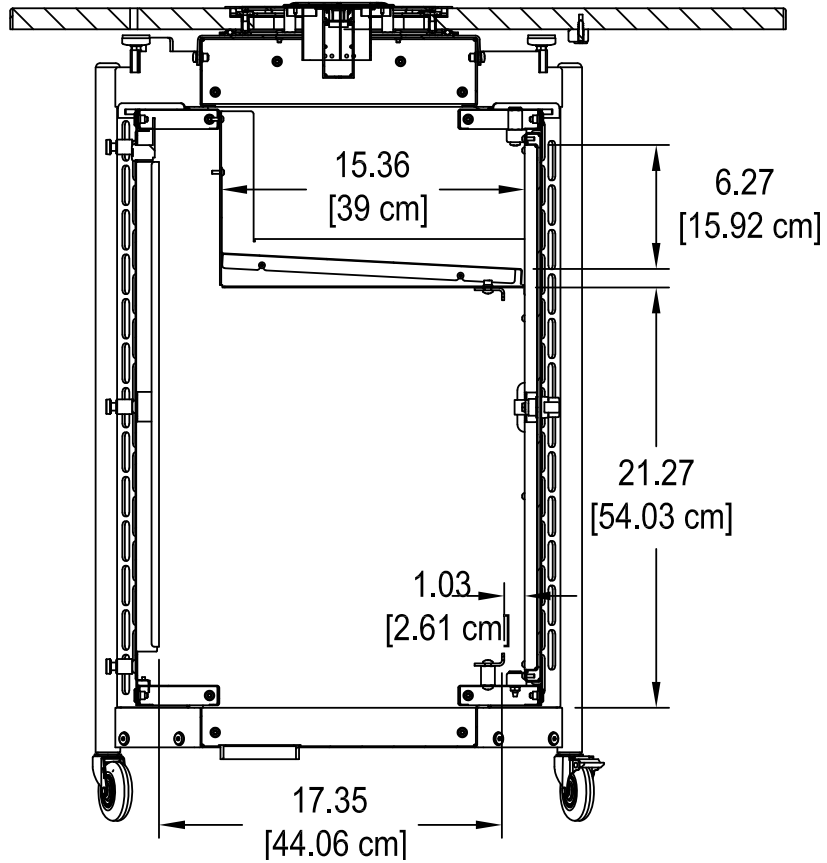

## Accessories

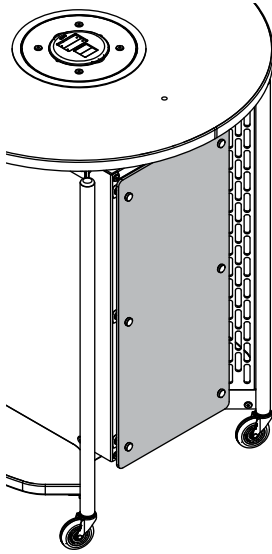

### Customized Logo Panel (full-height) - 55572

- Attaches to audience-side panel with heavy-duty magnets
- Clear acrylic
- Aluminum stand-offs
- To get panel customized, contact Spectrum for details
- New logos require a first time logo charge
- Customer-installed

Panel dimensions:	13.438"W [34.13 cm] x 30.28"H [76.9 cm] x .25"D [6.35 mm]
Available logo area:	11.438"W [29 cm] x 25.5"H [64.8 cm]
Unit weight:	5 5 lb [2.3 kg]
Shipping weight:	9 lb [4.1 kg]

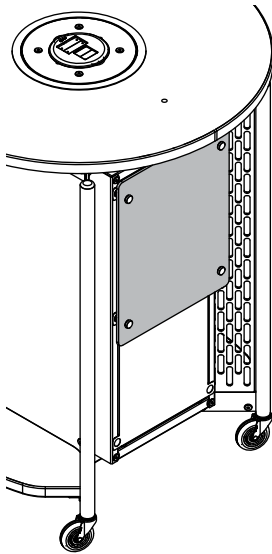

### Customized Logo Panel (half-height) - 55571

- Attaches to audience-side panel with heavy-duty magnets
- Clear acrylic
- Aluminum stand-offs
- To get panel customized, contact Spectrum for details
- New logos require a first time logo charge
- Customer-installed

Panel dimensions:	13.438"W [34.13 cm] x 17.14"H [43.5 cm] x .25"D [6.35 mm]
Available logo area:	11.438"W [29 cm] x 12.4"H [31.5 cm]
Unit weight:	3 lb [1.4 kg]
Shipping weight:	5 lb [2.3 kg]

## Worksurface Interface Panels

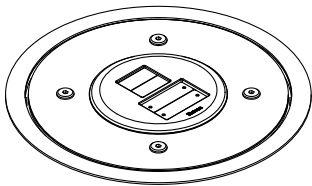

**Cable Cubby 100 - 55574**  
(CC100 not included)

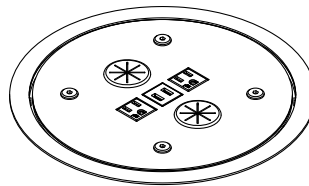

**Dock 1100 - 55575**  
(2 AC outlets, 2 USB-C ports)

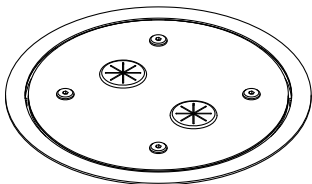

**Grommet - 55573**

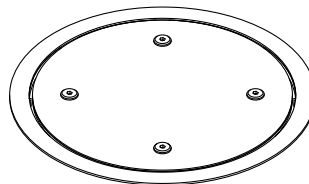

**Custom - 55576**  
(6" diameter of available space)

Note: Spectrum can customize a blank interface panel to your device specifications within the 6" diameter available as long as there is clearance of objects under the worksurface.

**Contact Spectrum for customizing details.**



**Summit Monitor Arm - 95539**  
**Summit Monitor Arm w/ USB - 95540**

- For 17"-35" monitors weighing 2.2-32 lb
- Mounts using grommet hole
- Compatible with all VESA® monitors - 75mm / 100mm VESA® adapter
- Cable management concealed in arm
- USB version has (2) 3.0 USB ports and (2) multi-media ports



**Titan Monitor Arm (12-13lb) - 95512**  
**Titan Monitor Arm (7.5-25lb) - 95522**  
**Titan Monitor Arm (12-31lb) - 95509**

- Mounts using grommet hole
- Compatible with all VESA® monitors includes 75mm and 100mm VESA® adapters
- Cable management concealed in arm

Note: The Summit and Titan monitor arms are the only monitor arms compatible with the Hyflex Lectern.



**7-Outlet Power Strip - 99024**

- Electrical Rating: AC 125V, 15 Amps
- 1000 Joules surge capacity
- 12' cord length
- LED switch
- UL Listed
- Shipping weight: 1.9 lb [.86 kg]

## Rack-mount Accessories

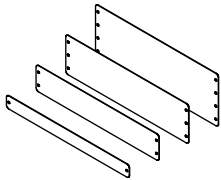

**Rack-Mount Blanks**

**1RU - 97510    3RU - 97512**  
**2RU - 97511    4RU - 97513**

- Fills rack spaces where components are not needed
- 16 ga steel
- Shipping weight: <1 lb [.45 kg]

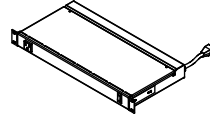

**9-Outlet Power Strip - 1RU - 99021**



- 8 outlets rear (breaker-protected)
- 1 convenience outlet front
- 115VAC, 60 Hz, 15 amps max
- 9' power cord
- Front LED power switch
- Enhanced surge protection
- ETL-listed, UL-listed
- 19"W [48.27 cm] x 9.25"D [23.5 cm] x 1.74"H [4.41 cm]
- Shipping weight: 8.7 lb [3.9 kg]

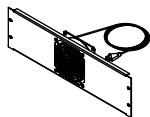

**Single Fan - 3RU - 97507**

- 50 cfm
- 120V~50/60 Hz, 15/13W
- RoHS
- 19"W [48.27 cm] x 1.56"D [3.97 cm] x 5.25"H [13.33 cm]
- Shipping weight: 3.78 lb [1.7 kg]

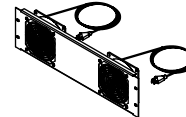

**Double Fan - 3RU - 97506**

- 100 cfm
- 120V~50/60 Hz, 15/13W
- RoHS
- 19"W [48.27 cm] x 1.56"D [3.97 cm] x 5.25"H [13.33 cm]
- Shipping weight: 5.47 lb [2.5 kg]

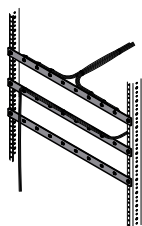

**Wire Lace Kit - 95517**

- Provides wire management
- Mounts to standard rack rails
- Includes (3) lace straps and mounting screws
- Includes (12) 5.5" zip ties
- Shipping weight: 1.25 lb [.57 kg]

See [spectrumfurniture.com](http://spectrumfurniture.com) for the latest accessories and detailed warranty information.

## Warranty

### **We will make it right for you!**

Thanks for choosing Spectrum! Spectrum is committed to provide complete customer satisfaction. Each of our products is manufactured from the best materials available and each product is stringently monitored throughout the production process through our P.A.C.E. program (Product Assurance to meet Customer Expectations).

We expressly warrant that Spectrum products will be of good quality and workmanship and free from defect for the period set out in the warranty from the date of delivery.

**For a listing of all product specific warranty terms please visit our website at:**

<https://www.spectrumfurniture.com/en/resources/purchasing-terms-warranty>

**1-800-235-1262**

Toll-free HELPLINE

**[spectrum@spectrumfurniture.com](mailto:spectrum@spectrumfurniture.com)**