

## Technical Specifications

SC36 Storage Cabinet	24025
SC48 Storage Cabinet	24026

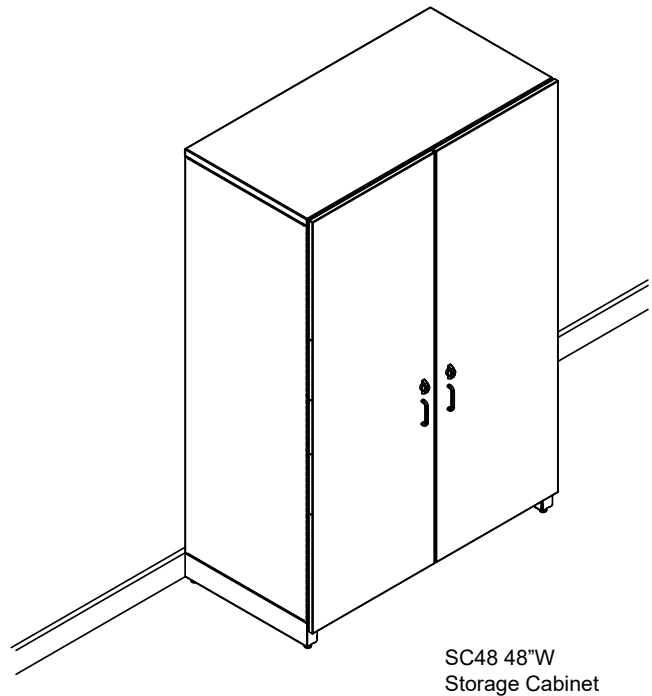
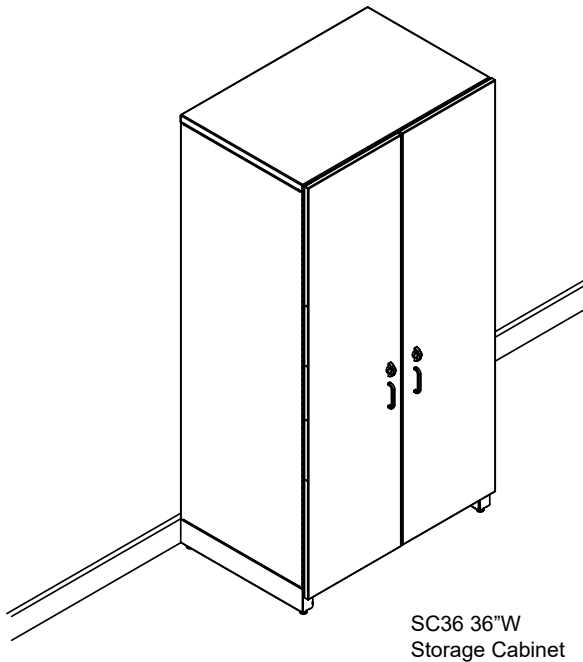

Designed for Makerspace, Fab Labs, and STEM environments. The Fab Lab storage cabinet can be used anywhere secure storage is needed.

## Features and Benefits

- Available in 36"W or 48"W
- Three adjustable shelves / one fixed shelf included
- Locking doors provide security
- 2" grommet access at lower rear panel and inside bottom panel
- Provisions for wall anchoring (fasteners not included)
- Adjustable glides
- Warranted to be free of all defects in materials and workmanship for 10 years
- Designed and assembled in Chippewa Falls, WI, USA

## Construction

- Metal components consist of 16 and 20-gauge steel
- All metal components are finished with a scratch-resistant powder coat epoxy
- Cabinet ships "knocked-down" and can be assembled at the final location

## Specifications

Overall dimensions (nominal)	36"W [91.44 cm] 48"W [121.92cm]	x 24"D [60.1 cm] x 72"H [182.88 cm]
Internal dimensions (nominal)	33"W [83.81 cm] 45"W [114.3 cm]	x 23.48"D [59.66 cm] x 65.88"H [167.33 cm]
Certifications / Compliance	Meets or exceeds applicable ANSI-BIFMA test standards	
Shipping	2 boxes	
Unit weight (nominal)	N/A - 36"W N/A - 48"W	
Shipping weight (nominal)	N/A - 36"W N/A - 48"W	

*Specifications subject to change without notice*

SC36 Fab Lab  
Storage Cabinet

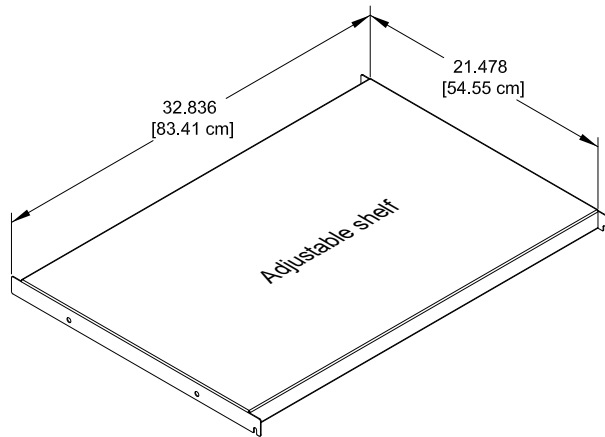
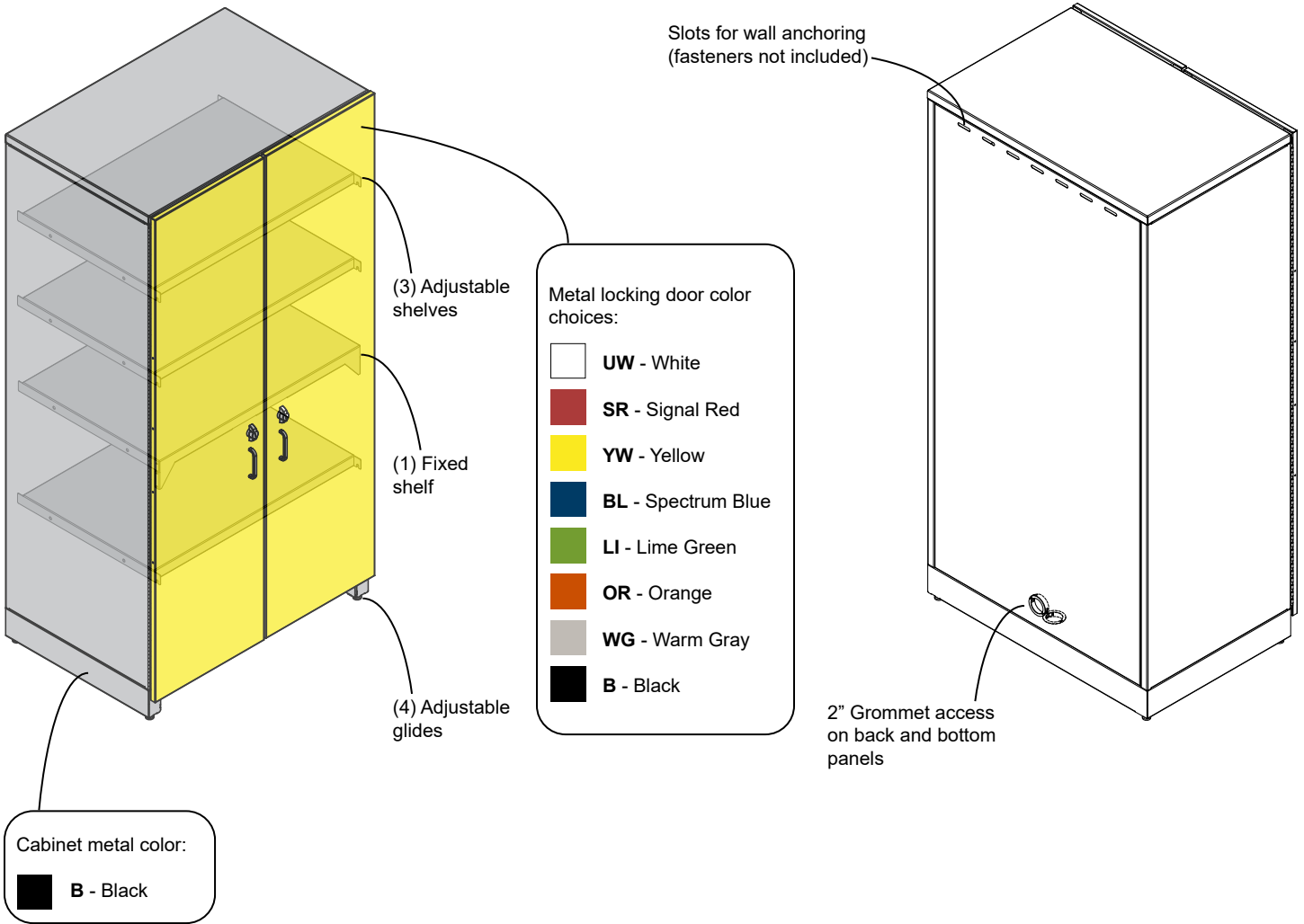

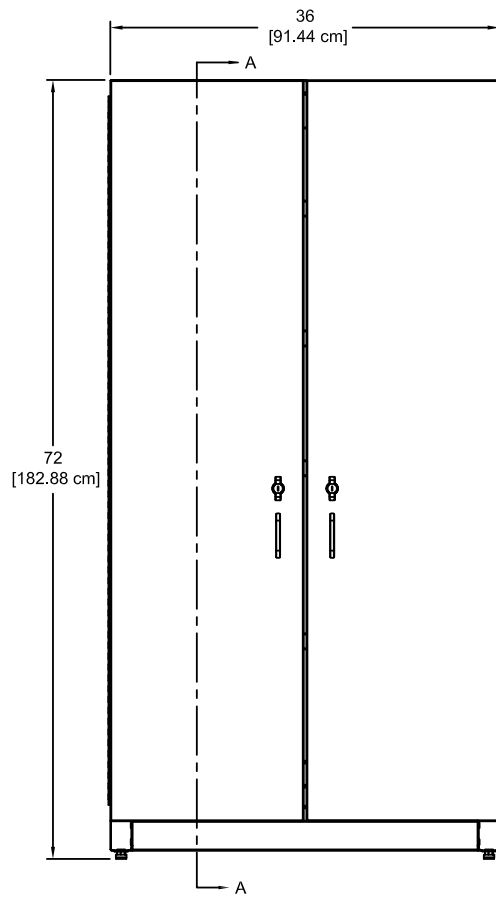
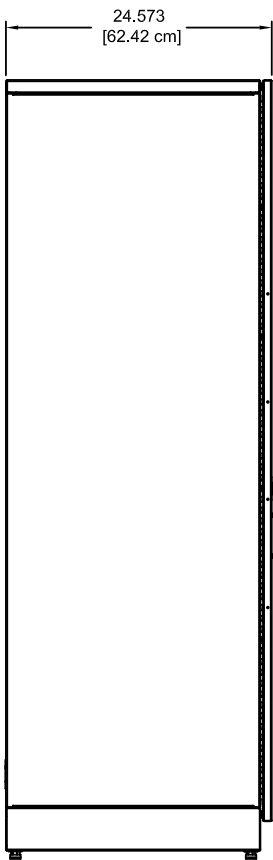
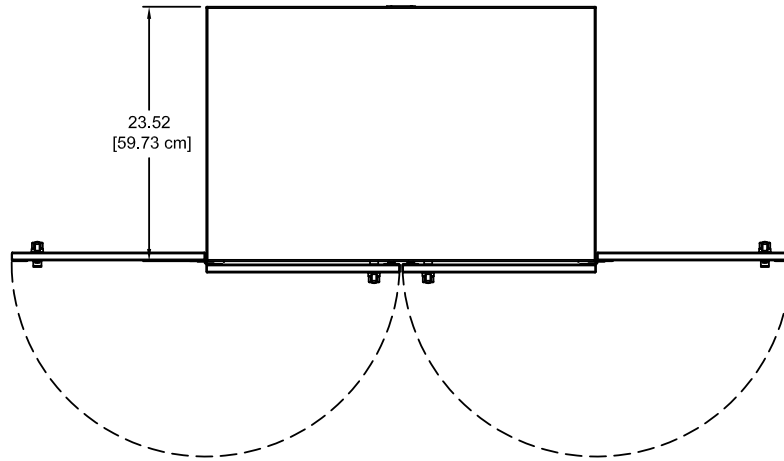

Section View A-A

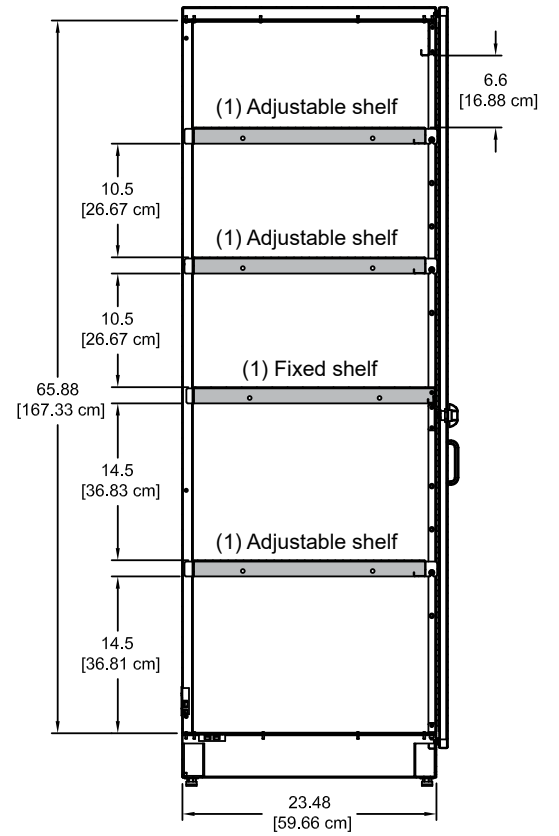

SC48 Fab Lab  
Storage Cabinet

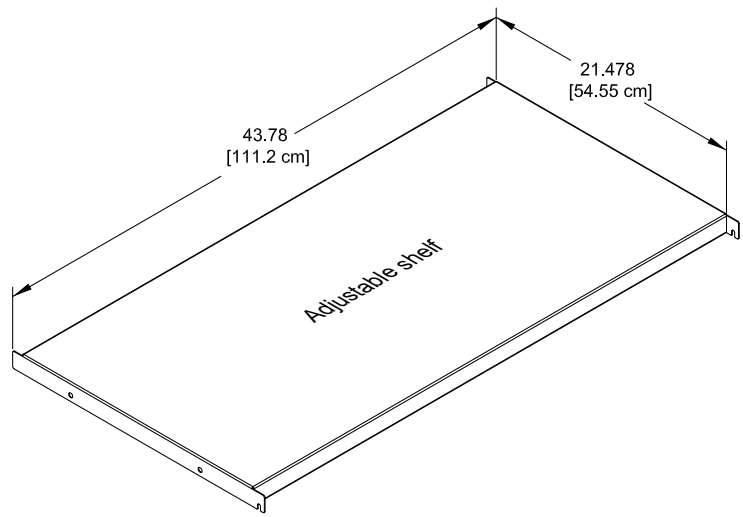
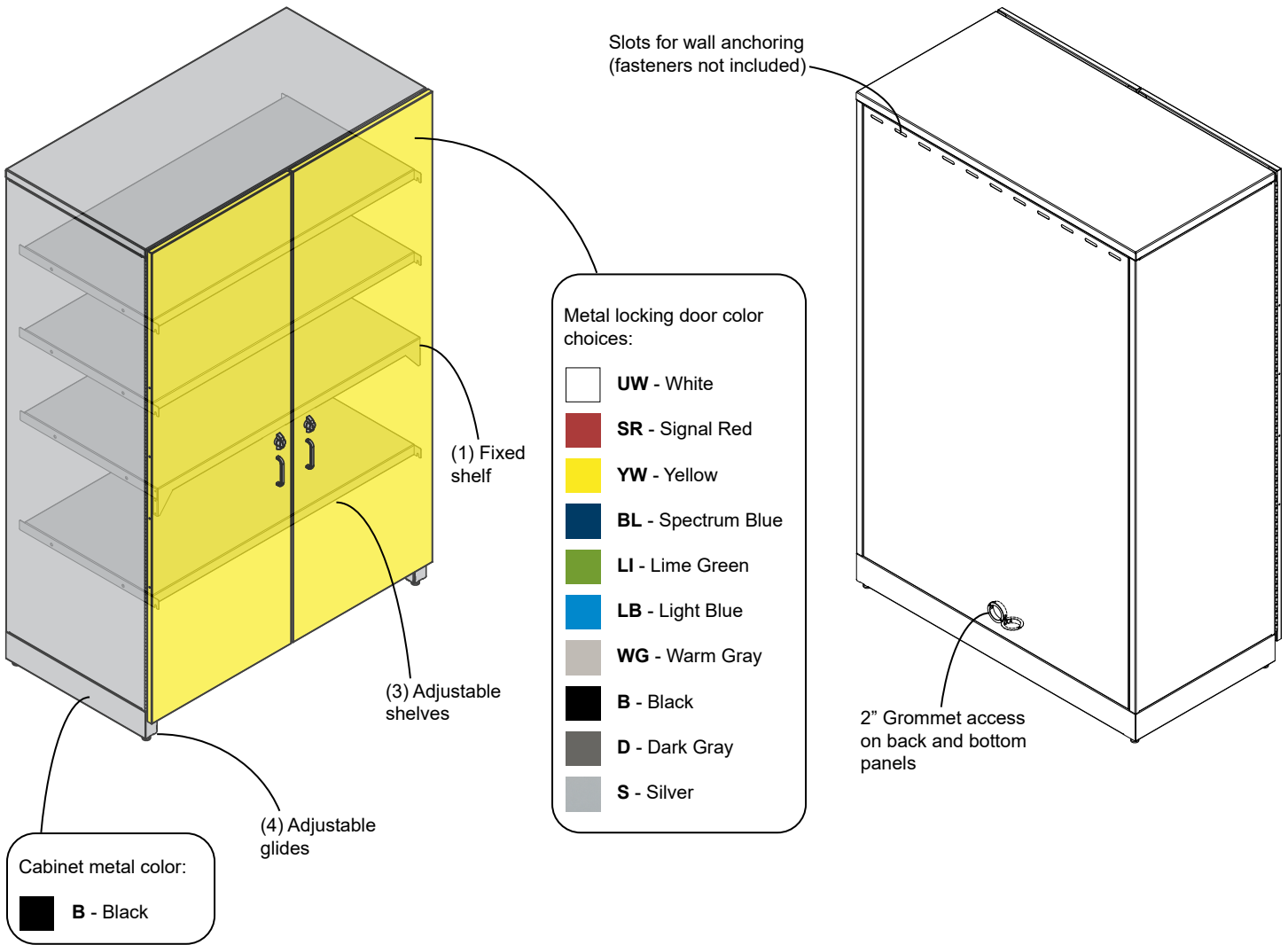

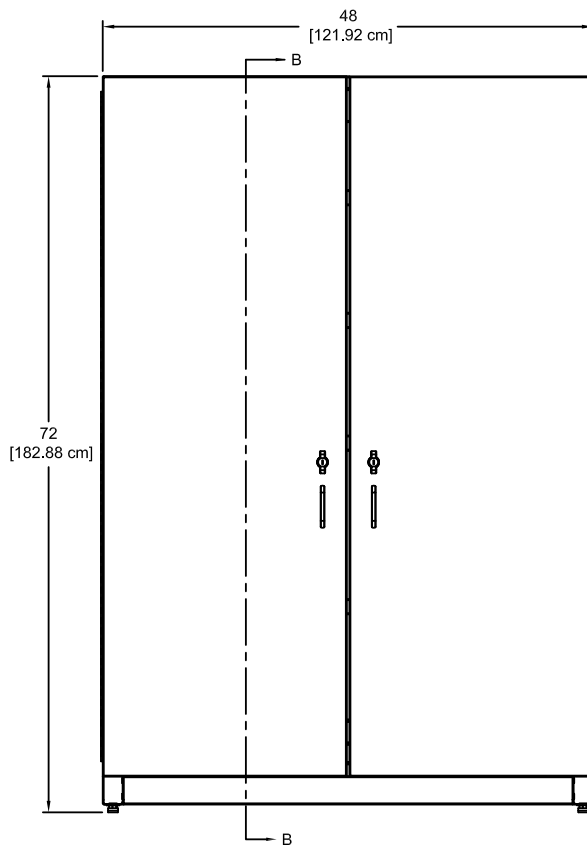
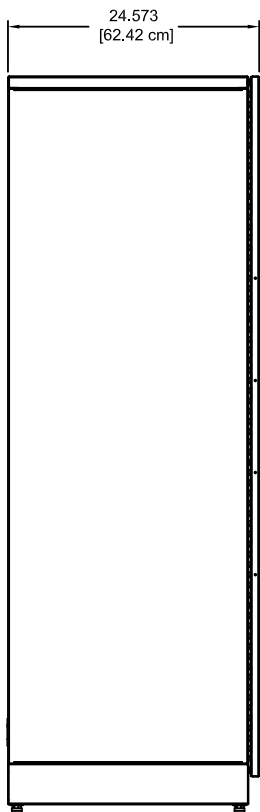
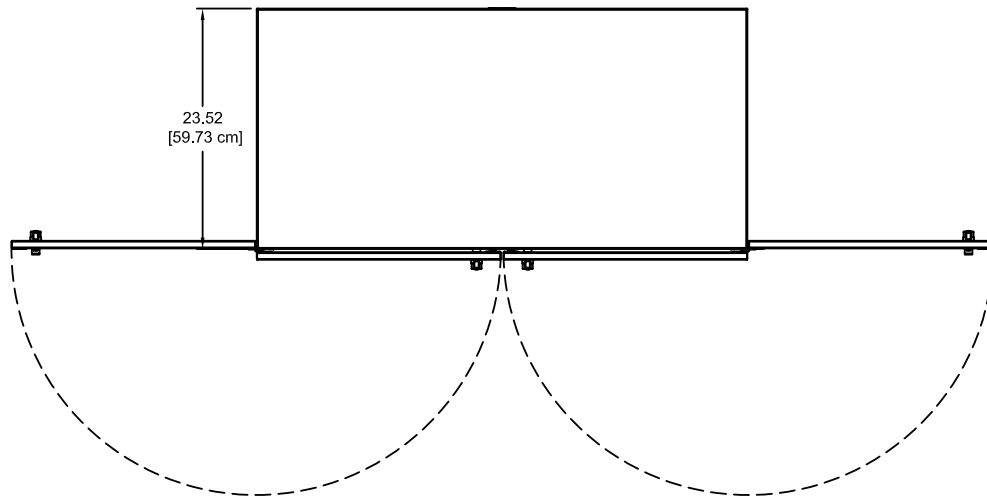

Section View B-B

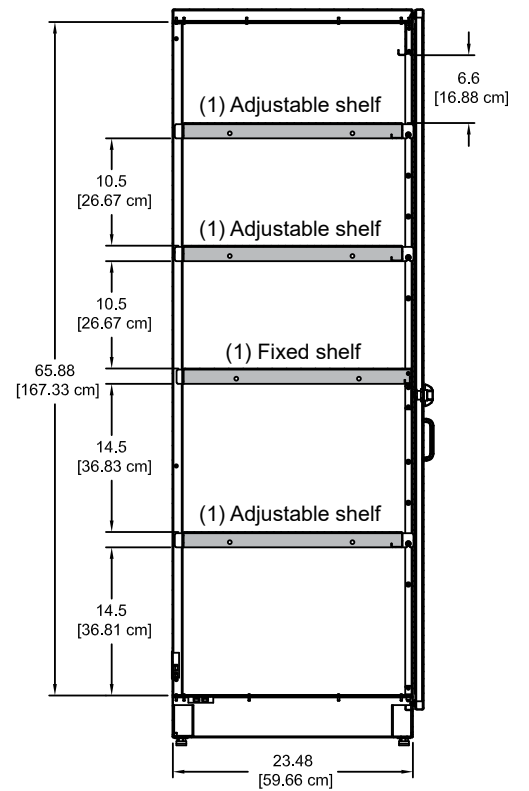

See [spectrumfurniture.com](http://spectrumfurniture.com) for the latest accessories and detailed warranty information.

## Warranty

### **We will make it right for you!**

Thanks for choosing Spectrum! Spectrum is committed to provide complete customer satisfaction. Each of our products is manufactured from the best materials available and each product is stringently monitored throughout the production process through our P.A.C.E. program (Product Assurance to meet Customer Expectations).

We expressly warrant that Spectrum products will be of good quality and workmanship and free from defect for the period set out in the warranty from the date of delivery.

**For a listing of all product specific warranty terms please visit our website at:**

<https://www.spectrumfurniture.com/en/resources/purchasing-terms-warranty>

**1-800-235-1262**

Toll-free HELPLINE

**[spectrum@spectrumfurniture.com](mailto:spectrum@spectrumfurniture.com)**