

Technical Specifications

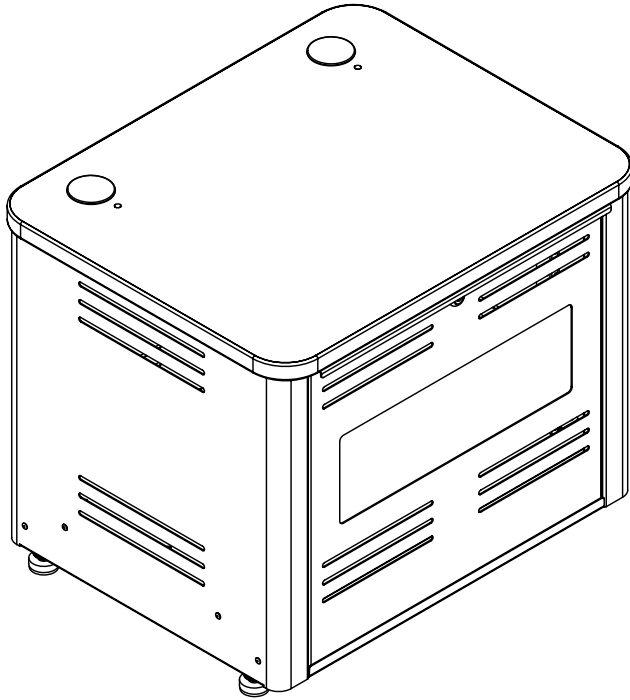





37123



The InVision Access equipment rack provides 8RU of secure rack storage wherever it may be needed. Glides and casters are included for stationary or mobile use. Available in the same color combinations as the InVision Access Table V2.

Features and Benefits

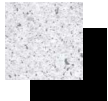
- Provides 8RU rack capacity
- Equipment rack can be integrated off-site, then wheeled into place
- Single cam locking front and rear panels
- Ventilated panels keep equipment cool, preventing overheating, and extending device life
- Access panels (one clear acrylic, one solid) provide monitoring and access to internal equipment
- Glides and casters included for stationary or mobile use (glides can be unscrewed to raise unit off casters for stationary use)
- Worksurface vinyl edging protects walls and furniture
- Ships fully-assembled for quick, simple integration and deployment
- Durable powder coated steel chassis provides a long-lasting finish
- Scratch and impact-resistant high-pressure laminate worksurface
- Grommet holes in worksurface and base panel provide cord access
- Includes 2 wire looms to route wires to / from table
- SCS Indoor Advantage Certified; meets or exceeds applicable ANSI-BIFMA test standards
- Warranted to be free of all defects in materials and workmanship for 10 years
- Assembled in Chippewa Falls, WI, USA

Color Options	
Standard laminate / metal color combinations	3mm vinyl worksurface edgeband color
Wild Cherry / Black (CHB)	 Wild Cherry
Fusion Maple / Black (FMB)	 Fusion Maple
Fusion Maple / Silver Sparkle (FMS)	 Fusion Maple
Indigo Organix / Black (IB)	 Black
Indigo Organix / Silver Sparkle (IS)	 Black
White Fiesta / Black (WFB)	 Black
White Fiesta / Silver Sparkle (WFS)	 Silver

Standard color combination refers to the quickest deliverable product color combination. Custom laminates and color combinations are available-additional lead-times and up-charges may apply. Call 1-800-235-1262 for further information.

Construction

- The worksurface is constructed from 1.063" NAUF (No Added Urea Formaldehyde) composite board with .030" high-pressure laminate on one face, and a balancing phenolic backer on the opposing face
- 16-gauge side panels, and front door
- All metal components are finished with a scratch-resistant powder coat epoxy
- Worksurface edges are covered with 3mm vinyl (color matching)
- Factory assembled. *(Wire looms installed by customer)*

Specifications

Rack rail	8RU
Wire looms	.75" [1.9 cm] dia x 64" [162.6 cm] length (includes 2)
Box dimensions (nominal)	N/A
Unit weight (nominal)	64 lb [29.1 kg]
Shipping weight (nominal)	90 lb [40.9 kg]

Specifications subject to change without notice

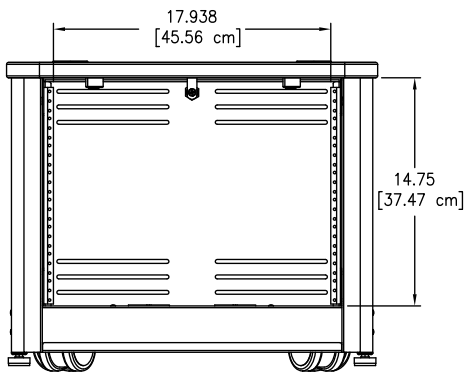
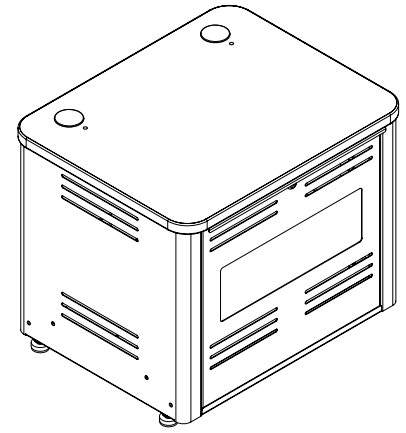

Front view
(shown with front panel removed)

Note: Rack-mount accessories with a depth greater than 14.3"D [36.3 cm] will not fit in the Access equipment rack. Check the dimensions of all equipment before installation.

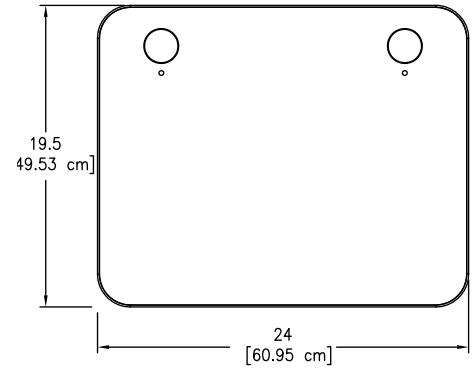

Top view

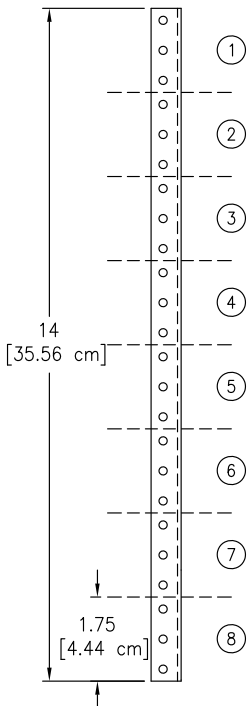

8RU available

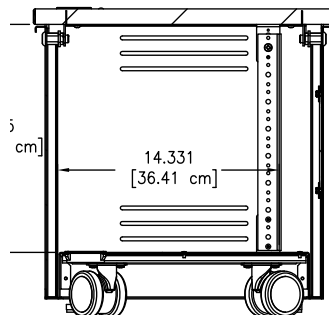
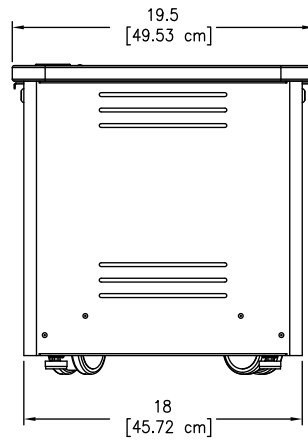

Section view A-A

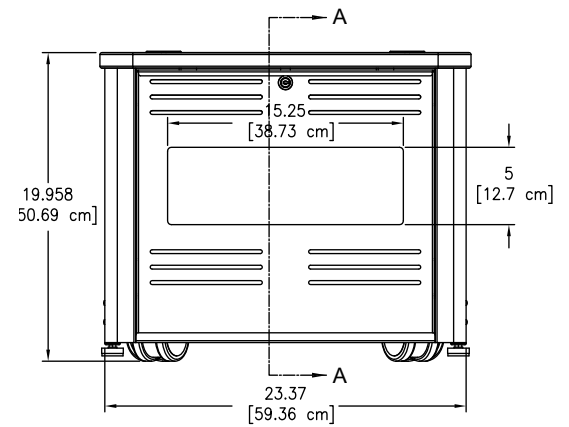

Bottom view

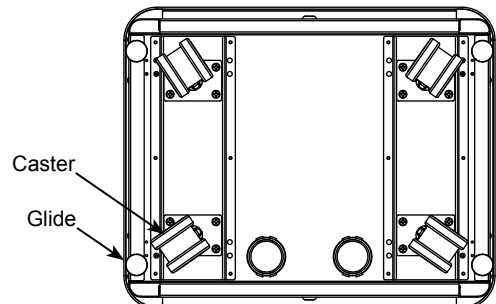

Warranty

WE WILL MAKE IT RIGHT FOR YOU!

Spectrum is committed to provide complete customer satisfaction. Each of our products is manufactured from the best materials available and each product is stringently monitored throughout the production process through our P.A.C.E. program (Product Assurance to meet Customer Expectations).

We expressly warrant that Spectrum products will be of good quality and workmanship and free from defect for the period set out in the warranty table below from the date of delivery. This warranty shall not apply to defects or damage resulting from misuse, abuse, neglect, improper care, modification or repair not authorized by Spectrum, or any other cause outside the control of Spectrum. Spectrum will, at its sole option, either repair or replace the defective product.

This warranty is exclusive; no other warranty, written or oral, is expressed or implied. This warranty is given by Spectrum to Buyer and to no other person or legal entity. No Spectrum dealer, distributor, agent or employee is authorized to make any modification or addition to this warranty.

NOTWITHSTANDING ANYTHING TO THE CONTRARY, SPECTRUM WILL NOT UNDER ANY CIRCUMSTANCES BE LIABLE FOR INDIRECT OR LIQUIDATED DAMAGES, INCLUDING CONSEQUENTIAL, INCIDENTAL AND SPECIAL DAMAGES. IN NO EVENT SHALL SPECTRUM'S LIABILITY, WHETHER UNDER CONTRACT OR WARRANTY, IN TORT OR OTHERWISE, EXCEED THE PURCHASE PRICE RECEIVED BY SPECTRUM FOR THE PRODUCT AT ISSUE AND "RECALL ACTION" EXPENSES. SPECTRUM SHALL NOT BE SUBJECT TO ANY OTHER OBLIGATIONS OR LIABILITIES, WHETHER ARISING OUT OF BREACH OF CONTRACT, WARRANTY, TORT (INCLUDING NEGLIGENCE AND STRICT LIABILITY) OR OTHER THEORIES OF LAW, WITH RESPECT TO PRODUCTS SOLD OR SERVICES RENDERED BY SPECTRUM, OR ANY UNDERTAKINGS, ACTS OR OMISSIONS RELATING THERETO.

Our Customer Service Department is ready to provide immediate attention to any questions, comments or concerns. They are available to answer your calls Monday through Friday from 7 am to 5 pm CST. In addition your product comments or concerns are welcome via e-mail at: spectrum@spectrumfurniture.com.

Warranty Table

effective 1/1/2015

Item	Warranty Period
Adjustable Crank/Electric Desk Legs	• 1 Year
Flat Panel Desk Gas Cylinders	
Chairs <ul style="list-style-type: none"> • Adjustable Height Chair Parts – including frames, gas cylinders, wood and plastic parts, control handles, casters • Adjustable Height Chair Upholstery • In-Stock Upholstery • Graded-In Fabrics and Customer Owned Material 	<ul style="list-style-type: none"> • 7 Years • 2 Years • 2 Years • No Warranty
Height Adjustable Columns and Lifts	• 1 Year
General Use Casters	
Electrical	• 2 Years
Keyboard/Mouse Trays	• 1 Year
Flat Panel Monitor Arms <ul style="list-style-type: none"> • Flat Panel Monitor Arm – General Parts • Flat Panel Monitor Arm – Gas Cylinders 	<ul style="list-style-type: none"> • 5 Years • 2 Years
Desks and Lecterns <ul style="list-style-type: none"> • Computer Desk Chassis • Cart Chassis • Lectern Chassis 	• 10 Years

